

# Application hints analogue power controller for SPC 1

## Control mode selection

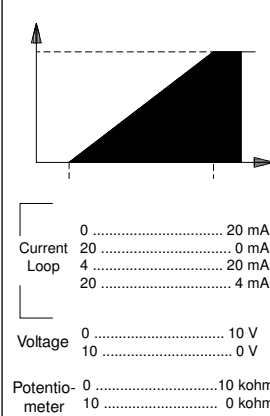
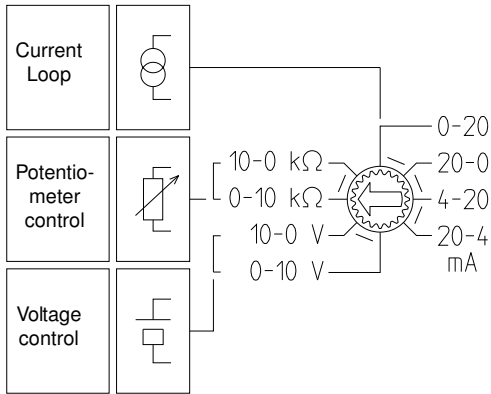

**Selection of control signal**  
The type of control signal, Current, Voltage or Potentiometer, can be selected on the rotary switch.

**Protection**  
The control inputs are protected against overload. If the current exceeds 25 mA the loop will be switched Off and the LED's will indicate failure. The input will not be damaged if the 24 V supply by mistake is connected to the signal input. Control input terminals are marked with + correct polarity must be observed. The control input is floating.

**Isolation Voltage:**  
Line to Control: 2.5kV AC  
**Isolation Voltage:**  
Supply to Control: 500V AC

## Function mode selection

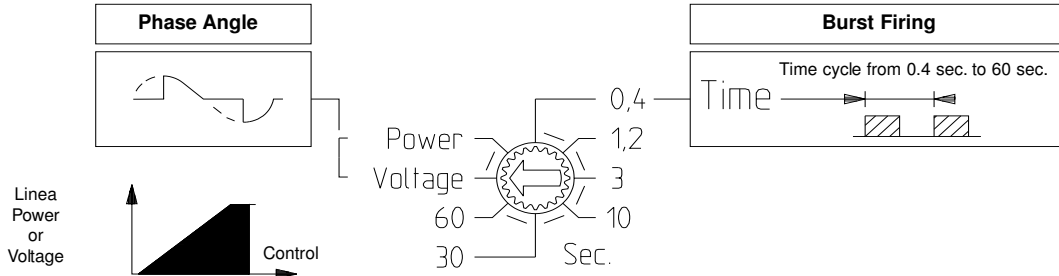

**Phase Angle:** Phase angle control is used for control of infrared lamps or heaters in IR heating applications  
**Two different operation modes can be selected.**  
**Lin. Voltage:** The load voltage varies linearly with the control signal  
**Lin. Power:** The power delivered to the load varies linearly with the control signal.

**Burst Firing**  
In Burst Firing mode full sine waves are supplied to the load. Consequently DC magnetising of the supply transformer is avoided. The number of sine waves varies linearly with the control signal. Adjustable cycle times from 400 ms to 60 sec.

## Line and load wiring hints for 1 or 3 phase application with or without neutral

**Single Phase 230 / 400 V AC**  
Phase Angle and Burst Firing applications  
230 and 400 V Heaters

**Three Phase with Neutral**  
Phase Angle and Burst Firing for heater applications

**Three Phase without Neutral Economy**  
With single pole contactor SC1DA4030 as slave.  
Only Burst Firing applications.

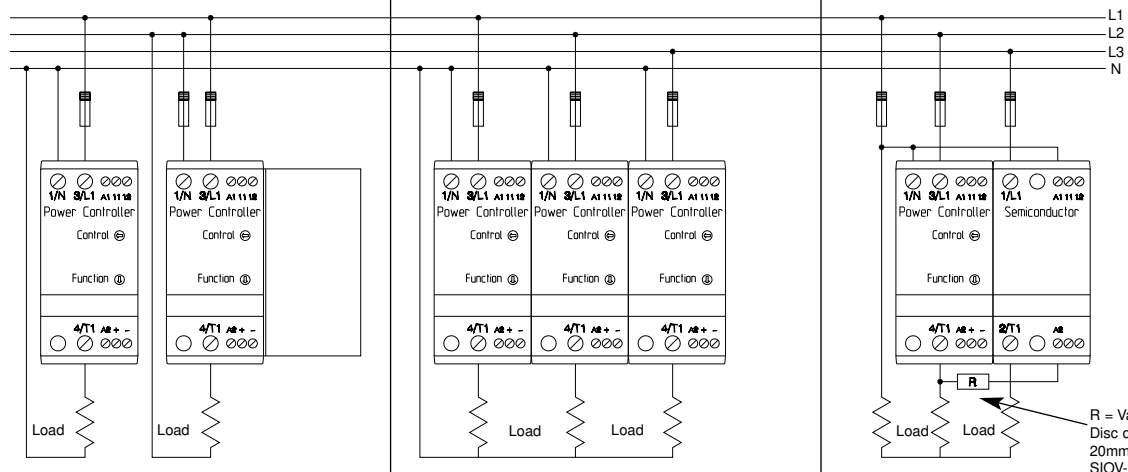

R = Varistor 230 VAC.  
Disc diameter min 20mm e.g. Siemens SIOV-S20K230

SPC1AD 2330= 6.9kW/SPC1AD 4030= 12kW Max  
SPC1AD 2350= 11.5kW/SPC1AD 4050= 20kW Max

3 x SPC1AD 2330 = 20.7kW Max  
3 x SPC1AD 2350 = 34.5kW Max

SPC1AD 4030 + SC1DA 4030= 20.7kW Max  
SPC1AD 4050 + SC1DA 4050= 34.5kW Max

# Application hints analogue power controller for SPC 1

## Different applications hints

### Current Loop:

0-20 mA or 4-20 mA. Controller inputs must be connected in series

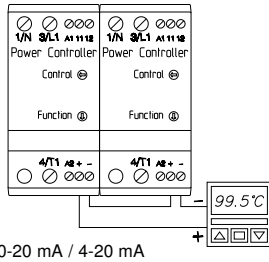

### Voltage Control :

Controller inputs must be connected in parallel

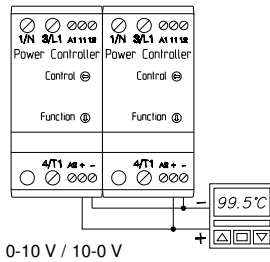

### Potentiometer Control :

10 kohm linear potentiometer

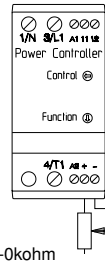

### Control Supply :

Controller supply must be connected in parallel

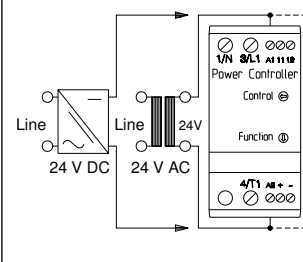

## Transformer applications hints

### Transformer Loads

SPC1 load driving capability includes transformer applications which means that low voltage loads can be controlled via an isolation transformer without any surge or DC magnetising of the transformer

### Switching Transformers

The problem in transformer switching is the magnetic circuit. When the transformer is switched Off, (H=0) the field (B) remains on a high level due to the high remanence of modern transformer core material. At initial turn-On where the remanence is unknown the SPC1 will soft-start to avoid the high current surge and at repetitive turn-on the switch-off polarity is "remembered" so next turn-on will be in the opposite polarity, thereby eliminating the high current surge normally seen in transformer applications. DC magnetising is eliminated by operating in full cycle mode only

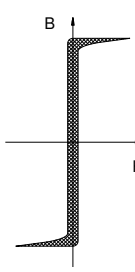
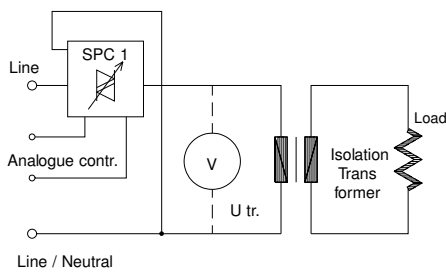

### Phase Angle Mode :

A initial turn On SPC 1 will soft-start the transformer to the voltage level set by the analogue input.

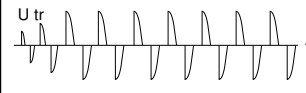

### Burst Firing Mode :

A initial turn On SPC 1 will soft-start the transformer to full On mode. The controller will only allow full cycles to be supplied to the transformer hereby eliminating current surges and DC saturation of the transformer.

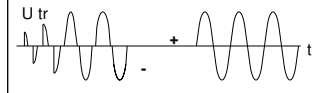

## Transformer applications hints

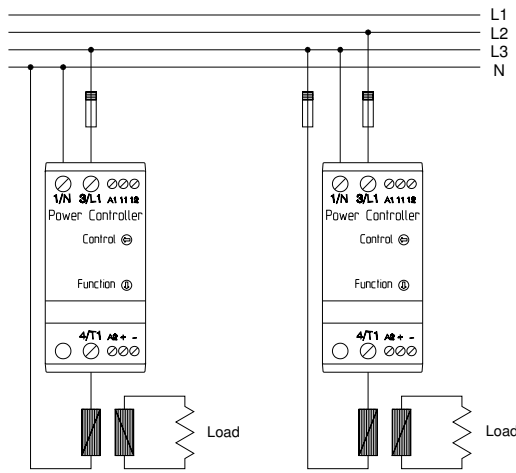

**Single Phase Line - Neutral**  
For 3 Phase applications use 3 x single phase circuit

**Single Phase Line - Line**

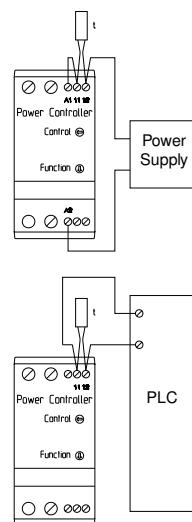

### Application Examples

The thermostat is connected in series with the control supply of the controller. When the controller heatsink temperature exceeds 90°C the control supply is switched Off. When the controller heatsink has dropped to approx. 60°C the control supply is switched On again.

### Application Examples

The thermostat is connected to a PLC or other form of controller for controlled shutdown in case of over temperature

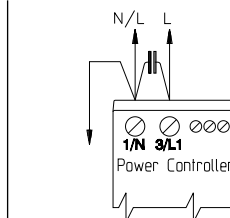

### EMC Specifications

SPC 1 is in conformity with EN60947-4-3 AC Semiconductor Contactors for non motor loads

### Burst Firing Control Mode:

No action necessary.

### Phase Angle Control Mode: I < 10 A

No action necessary.

Internal filter is sufficient.

### Phase Angle Control Mode: I > 10 A

Connect 1uF capacitor from N/L to L1 as shown above.