

## 3-Phase electronic motor contactor (Direct On Line)

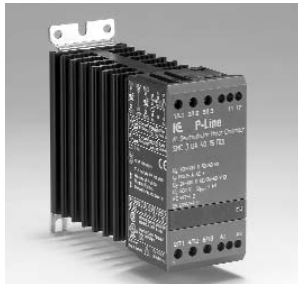

- For Direct On Line start of 3 phase motors
- Rated operational voltage up to 600 VAC 50/60 Hz
- Rated operational current up to 15A AC-3
- Versatile control circuit: 24-480VAC / 24-60VDC
- Unlimited number of start/stop operations / hour
- LED Status indication
- Meets EN 60947-4-2 requirements
- Requires only 45 mm DIN rail space

### Item selection and technical specifications

Load ratings AC-53 motor load stand. AC-4 motor load inching / plugging	Control voltage	Item number by 208-240VAC 50/60Hz Line Voltage	Item number by 400-480VAC 50/60Hz Line Voltage	Item number by 550-600VAC 50/60Hz Line Voltage	Module-width
15A AC-53	24-60VDC / 24-480VAC	SMC 3 DA 2315 DOL	SMC 3 DA 4015 DOL	SMC 3 DA 6015 DOL	45mm

### Output load specification

Operational current AC-53	15A	Min. operational current	50mA
Leakage current	5mA ACmax.	Duty cycle	100%

### Control terminal specifications

Control voltage	24-60 VDC/24-480 VAC	Control current / power max.	6mA / 1.5 VA
Pick-up voltage max.	20.4 VAC / DC	Max. control voltage	510 VAC
Drop-out voltage min.	5 VAC / DC	Response time max.	1 cycle

### Thermal specification

Power dissipation for continuous operation PDmax	2.2 W/A	Operation in ambient temperatures exceeding 40°C is possible if the power dissipation is limited either by reducing the steady-state current or by reducing the duty-cycle of the soft starter as shown in the table.		
Power dissipation for intermittent operation PD	2.2 W/A x dutycycle			
Cooling method	Natural convection			
Mounting	Vertical +/-30°			
Operating temperature range EN 60947-4-2	-5°C to 40°C			
Storage temperature EN 60947-4-2	-20°C to 80°C			
Max. operating temperature with current derating	60°C			
		By 40°C	By 50°C	By 60°C
		100% load Duty-cycle 100%	80% load Duty-cycle max. 0.8	70% load Duty-cycle max. 0.65

### Environment

Degree of protection	IP 20	Pollution degree	3
----------------------	-------	------------------	---

\*This products has been designed for class A equipment. Use of the product in domestic environments may cause radio interference, in which case the user may be required to employ additional mitigation methods.

\*UL:Use thermal overload protection as required by the National Electric Code. When protected by a non-time delay K5 or H Class fuse, rated 266% of motor FLA, this device is rated for use on a circuit capable of delivering not more than 5,000 rms. symmetrical amperes, 600 V maximum. Maximum surrounding temperature 40°C.

### Insulation specifications

Rated insulation voltage	Ui 660 Volt
Rated impulse withstand voltage	Uimp. 4 kVolt
Installation category	III

### Utilisation Categories EN60947-4-2

<b>Category AC - 53</b>	Starting, switching off motors during running.
<b>Category AC - 4</b>	Starting, plugging, reversing the motor rapidly while the motor is running.
<b>CategoryAC - 52a</b>	Control of slipring motor stators
<b>CategoryAC - 53a</b>	Control of squirrel cage motor
<b>Category AC - 58a</b>	Control of hermetic refrigerant compressors with automatic resetting of overload releases

### Approval

ULc Std No. 508 / CAN/CSA-C22.2

### Mounting and cable wiring information

Mounting information see page 36 / Cable wiring see page 37

### Dimensions (se also page 36)

Type	H	D	W
45 mm module	94 mm	128.1 mm	45 mm

### EMC

This component meets the requirements of the product standard EN60947-4-2 and is CE marked according to this standard.

# 3-Phase electronic motor contactor (Direct On Line)

## Wiring specifications

SMC 3 DA XX15 DOL

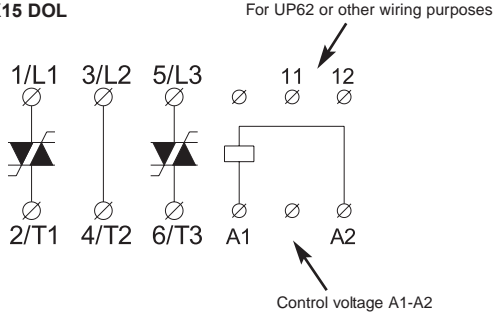

## Short-circuit protection by circuit breaker or fuses

Two type of short-circuit protection can be used:

- Short-circuit protection by circuit breaker.
- Short-circuit protection by fuses.

Short-circuit protection is divided into 2 levels **Type 1** or **Type 2**

**Co-ordination Type 1:** Short-circuit protects the installation

**Co-ordination Type 2:** Short-circuit protects the installation and the semiconductors inside the motor controller

### a) Short-circuit protection by circuit breaker

A 3-Phase motor with correctly installed and adjusted overload relay will not short circuit totally to earth or between the 3 phases. Part of the winding will normally limit the short circuit current to a value that will cause instantaneous magnetic tripping of the circuit breaker without damage to the electronic contactor. The magnetic trip response current is approx. 11 times the max. adjustable current.

### b) Short-circuit protection by fuses

Type 1: SMC 3 DA XX15 DOL Protection max. 50 A gL/gG

Type 2: SMC 3 DA XX15 DOL Protection max. I<sub>2t</sub> of the fuse 1800 A<sup>2</sup>s

Fuses from e.g. Ferraz, Siba, Bussmann can be used as short-circuit protection Type 2

More information concerning Co-ordination Type 2 see page 37

## Thermal overload protection (see also page 36)

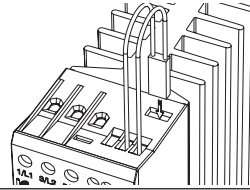

Optional thermal overload protection is possible by inserting a thermostat in a slot on the right hand side of the soft starter. Type number UP62

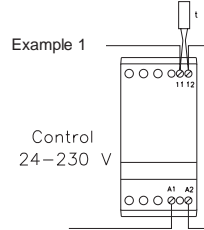

The thermostat can be connected in series with the control circuit of the soft starter. When the temperature of the heatsink exceeds 90°C the soft starter will switch Off.

**Note:** When the temperature has dropped approx. 30°C the soft starter will automatically be switched on again.

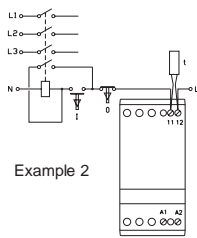

The thermostat is connected in series with the control circuit of the main contactor. When the temperature of the heatsink exceeds 90°C the main contactor will switch Off.

A manual reset is necessary to restart this circuit.

## SMC 3 DOL General application information

The SMC 3 DOL has been developed for cranes and other harsh applications where inching, jogging and plugging is frequently used and where a high number of operating cycles are essential. In such applications the lifetime of the equipment is normally limited by the short lifetime of the electromechanical contactor. Electromechanical contactors are not designed to switch off motors in locked rotor- or overload conditions where the current is 6 times the nominal operational current (AC-4). The severe arcing will burn the contact elements resulting in unreliable contact function. The Semiconductor Contactor will close the contacts in the zero crossing of the mains voltage and switch-Off will always occur in the zero crossing of the motor current in this way voltage kickback from the inductive motor windings is avoided. The lifetime, therefore, of the Semiconductor Contactor will always be at least one decade longer than the electromechanical contactor.

## Overload Protection in Motor Control Reversing

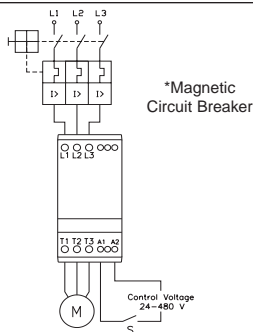

Overload protection of the motor is easily achieved by installing a manual thermal magnetic circuit breaker on the supply side of the motor.

The circuit breaker provides means for padlocking and the necessary clearance for use as a circuit isolator according to EN 60204-1.

Adjust the current limit on the MCB according to the rated nominal current of the motor

\*Use UL approved Magnetic Circuit Breaker or UL specified back-up fuse type K5 or H Class

## Comparison of lifetime in different utilization categories

Utilization-categories	Typical applications	Electro-mechanical Contactor	Semiconductor Contactors SMC3DA...DOL
AC-52a	Control of slip-ring motors, starting, switching Off	0.7 Mill. Cycles	25 Mill. Cycles
AC-53a	Control of squirrel-cage motors, starting, switching Off	1.3 Mill. Cycles	25 Mill. Cycles
AC-4	Control of squirrel-cage motors, starting, plugging, inching	0.06 Mill. Cycles	5 Mill. Cycles