

Starting Torque Limiter (STL Soft Starter for 1&3-phase motors, one controlled phase)

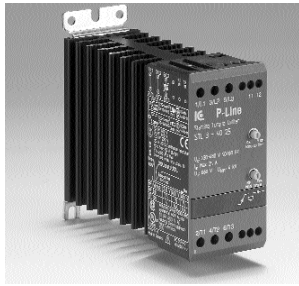

- Rated operational voltage up to 600 VAC 50/60 Hz
- Rated operational current: 15 Amp or 25 Amp
- Ramp Up adjustable from 0.5-5 sec
- Initial torque adjustable from 0-85%
- LED status indication
- Meets EN 60947-4-2 requirements
- High number of start/stop operations pr. hour. See data

Item selection and technical specifications (see also motor table at page 11)

| Load ratings | Item number by 110-127VAC 50/60Hz Line Voltage | Item number by 208-480VAC 50/60Hz Line Voltage | Item number by 550-600VAC 50/60Hz Line Voltage | Ramp-Up adjustment | Torque adjustment | Module-width | | |
|---------------------------------|--|--|--|---------------------------|-------------------------------------|--------------|--|--|
| Items for 1-phase motors | | | | | | | | |
| 15A AC-53a | STL 1 1215 | STL 1 4015 | STL 1 6015 | Ramp-up time 0.5 - 5 sec. | 0- 85% adjustable of nominal torque | 45mm | | |
| 25A AC-53a | STL 1 1225 | STL 1 4025 | STL 1 6025 | | | 45mm | | |
| Items for 3-phase motors | | | | | | | | |
| 15A AC-53a | STL 3 1215 | STL 3 4015 | STL 3 6015 | | | 45mm | | |
| 25A AC-53a | STL 3 1225 | STL 3 4025 | STL 3 6025 | 45mm | | | | |

Load specified with utilisation category AC-53a

STL 1 and 3 XX/15/25 AC-53a:
No by-pass contactors is necessary during running

Output load specification

| STL 1 and 3 XX15 | More info. page 45 | STL 1 and 3 XX25 | More info. page 45 |
|----------------------------------|--------------------|----------------------------------|--------------------|
| Overload current profile AC-53a | X-Tx:8-3 :100-3000 | Overload current profile AC-53a | X-Tx:8-3 :100-3000 |
| Overload relay trip class AC-53a | 10 or 10A | Overload relay trip class AC-53a | 10 or 10A |
| Min. operational current: 50mA | | Min. operational current: 50mA | |

Thermal specification

| | | |
|--|--------------------|---|
| Power dissipation for continuous operation PDmax | 1W/A | Operation in ambient temperatures exceeding 40°C is possible if the power dissipation is limited either by reducing the steady-state current or by reducing the duty-cycle of the soft starter as shown in the table. Max.cycle time 15min. |
| Power dissipation for intermittent operation PD | 1W/A x dutycycle | |
| Cooling method | Natural convection | |
| Mounting | Vertical +/-30° | |
| Operating temperature range EN 60947-4-2 | -5C° to 40°C | |
| Max. operating temperature with current derating | 60°C | |
| Storage temperature EN 60947-4-2 | -20C° to 80°C | |

| By 40°C (STL X XX25) | By 50°C (STL X XX25) | By 60°C (STL X XX25) |
|---------------------------|------------------------------|-------------------------------|
| 100% load Duty-cycle 100% | 80% load Duty-cycle max. 0.8 | 70% load Duty-cycle max. 0.65 |

Environment

| | | | |
|----------------------|-------|------------------|---|
| Degree of protection | IP 20 | Pollution degree | 3 |
|----------------------|-------|------------------|---|

Approval

cUL Std No. 508

*UL: Use thermal overload protection as required by the National Electric Code. When protected by a non-time delay K5 or H Class fuse, rated 266% of motor FLA, this device is rated for use on a circuit capable of delivering not more than 5,000 rms. symmetrical amperes, 600 V maximum. Maximum surrounding temperature 40°C.

Insulation specifications

| | |
|---------------------------------|---------------|
| Rated insulation voltage | Ui 660 Volt |
| Rated impulse withstand voltage | Uimp. 4 kVolt |
| Installation category | III |

Functional diagram

Mains Ue L1,L2,L3

Motor voltage

LED 1

LED 2



Mounting and cable wiring information

Mounting information see page 44 / Cable wiring see page 45

Dimensions (see also page 36)

| Type | H | D | W |
|--------------|-------|----------|-------|
| 45 mm module | 94 mm | 128.1 mm | 45 mm |

EMC

This component meets the requirements of the product standard EN60947-4-2 and is CE marked according to this standard. These products has been designed for class A equipment. Use of the product in domestic environments may cause radio interference, in which case the user may be required to employ additional mitigation methods.

Starting Torque Limiter (STL Soft Starter for 1&3-phase motors, one controlled phase)

Wiring specifications

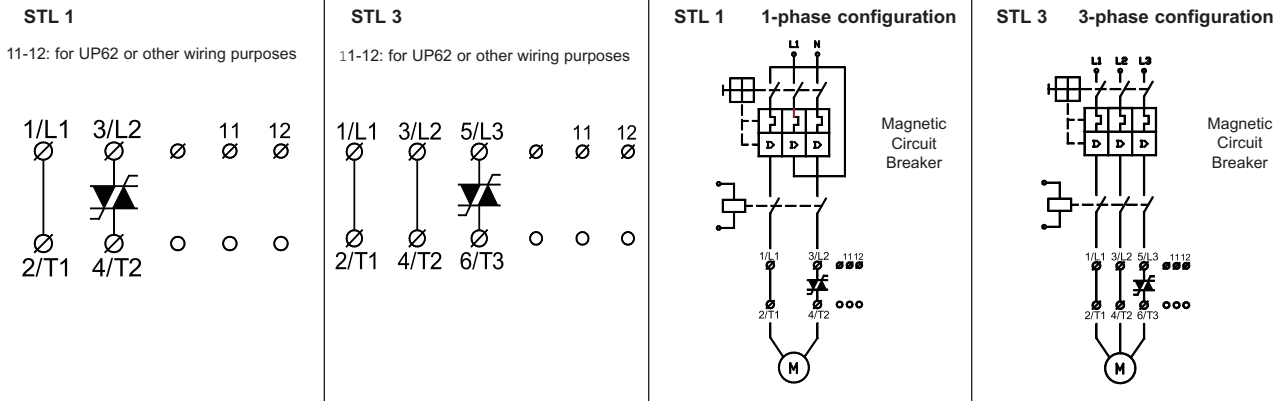

How to adjust ramp times and initial torque

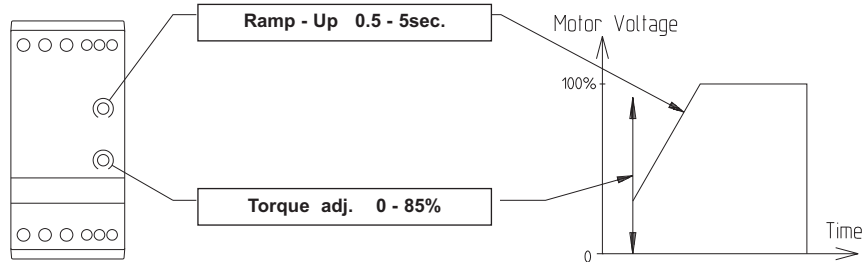

A. Ramp-Up time and initial torque (standard load) Use screwdriver 2 mm x 0.5 mm for adjustment

- 1) Set the *Ramp-Up* switch to maximum
- 2) Decrease the *Ramp-Up* time until desired start is achieved
- 3) Set the *Initial Torque* switch to minimum
- 4) Switch the contactor ON for a short time. If the load does not rotate immediately increment the *Initial Torque* and try again. Repeat until the load starts to rotate immediately on start-up

NOTE:

- a) Control of the motor torque is achieved by acting on the motor voltage. The motor speed depends on the torque produced by the motor and the load on the motor shaft.
- b) A motor with little or no load will reach full speed before the voltage has reached its maximum value.
- c) Repeated starts may trip the motor protection relay.

Short-circuit protection by circuit breaker or fuses

Two type of short-circuit protection can be used:

- a) Short-circuit protection by circuit breaker.
- b) Short-circuit protection by fuses.

Short-circuit protection is divided into 2 levels **Type 1** or **Type 2**

Co-ordination Type 1: Short-circuit protects the installation

Co-ordination Type 2: Short-circuit protects the installation and the semi-conductors inside the motor controller

a) Short-circuit protection

Co-ordination type 1 will be obtained when using magnetic circuit breakers or standard gL/GI fuses.

Co-ordination type 2 will be obtained when using semiconductor fuses. When using semiconductor fuses the SCR will not be damaged due to transients and short circuits. The table indicates suitable fuses for co-ordination type 2 protection.

b) Short-circuit protection by fuses

| | |
|----------------------|--|
| Type 1: STL 1/3 XX15 | Protection max. 50 A gL/gG |
| Type 1: STL 1/3 XX25 | Protection max. 80 A gL/gG 63A T |
| Type 2: STL 1/3 XX15 | Protection max. i^2t of the fuse 1800 A ² S |
| Type 2: STL 1/3 XX25 | Protection max. i^2t of the fuse 6300 A ² S |

Fuses from e.g. Ferraz, Siba, Bussmann can be used as short-circuit protection Type 2

More information concerning Co-ordination Type 2 see page 45

Start of single phase motor (application example)

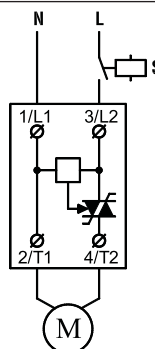

- By start S shall be switched On
- The STL starts to Ramp-Up the motorvoltage
- When the motor has to stop, S shall be switched off
- The STL 1 is now ready for a new start
- The STL 1 is applicable for standard single phase motors, capacitive motors, transformers etc.

Thermal overload protection (see also page 44)

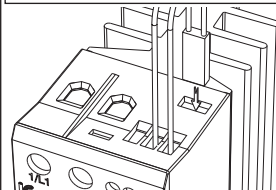

Optional thermal overload protection is possible by inserting a thermostat in a slot on the right hand side of the soft starter. Type number UP62