

The Move represents the evolution from the popular Prima 2.0 model. The brand new hydroformed 6000 series alloy front triangle has polygonal cross section top tube and a hexagonal cross section down tube, to ensure confident handling and rigidity.

Also new is the C-HS1 headset system and the fork, made specifically to work together with the new headset to improve manoeuvrability and steering precision.

Technical size

Size	Ps	Os	Pccs	Scs	Sc°	A	C	Hs	P	O
42s	433	492	390	98	75.49°	580	400	119	510	510
45s	463	502	410	104	75.14°	582	401	122	515	518
48s	493	517	440	117	74.58°	585	403	129	520	530
50s	513	526	460	127	73.99°	589	406	147	540	540
52s	533	536	480	137	73.57°	593	407	164	560	550
54s	553	552	500	147	72.83°	596	412	176	580	565
56s	573	569	525	156	72.71°	606	413	183	600	580
58s	593	580	540	160	72.70°	614	413	203	620	590

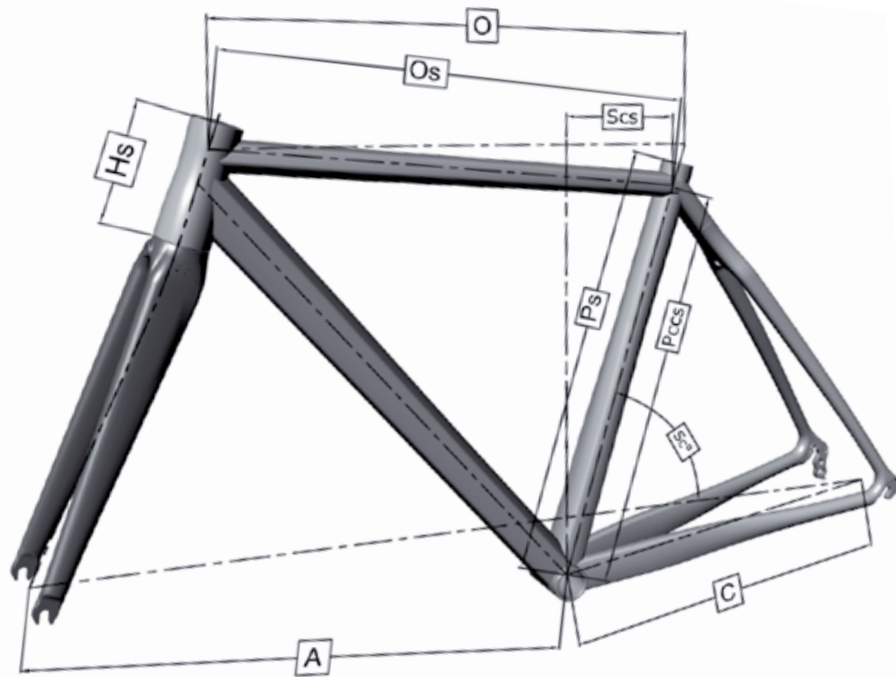

Size	Size
Pccs	Seat tube length (centre to centre)
Ps	Seat tube length (centre to top)
P	Effective seat tube length
Os	Top tube length
O	Top tube length (horizontal)
Sc°	Seat angle
Scs	Seat cluster offset
C	Chainstay length
A	Front centre
Hs	Tube length

MOVE 105

Specific list

Frame	COLNAGO MOVE
Fork	COLNAGO STREET 3.0
Chain Wheel	SHIMANO FC-R565 50X34T
Front Derailleur	SHIMANO 105
Rear Derailleur	SHIMANO 105
Derailleur Lever Set	SHIMANO 105
Gear	COLNAGO TIAGRA 105 11-25T
Wheels Set	COLNAGO RACE 24
Tires	CONTINENTAL ULTRA SPORT 700x23C
Brakes	COLNAGO X-BRAKE 3
Handle Bar	DEDA RHM EL
Handle Bar Stem	DEDA EL
Saddle	COLNAGO Z7
Seat Post	DEDA RS EL
_Water Bottle Bolt	M4X0.75X8 2.5 HEX m/m STL
_Seat Clamp	34.9X32.0
_Head Set	FSA NO.44E/51 28.6-46.8-33 H=16.5

	Chain Wheel	Stem	Handlebar (Center-Center)
42sl	165mm	75mm	40
45sl	170mm	90mm	40
48sl	170mm	100mm	40
50sl	170mm	115mm	40
52sl	172.5mm	115mm	42
54sl	172.5mm	115mm	42
56sl	175mm	130mm	42
58sl	175mm	130mm	44