

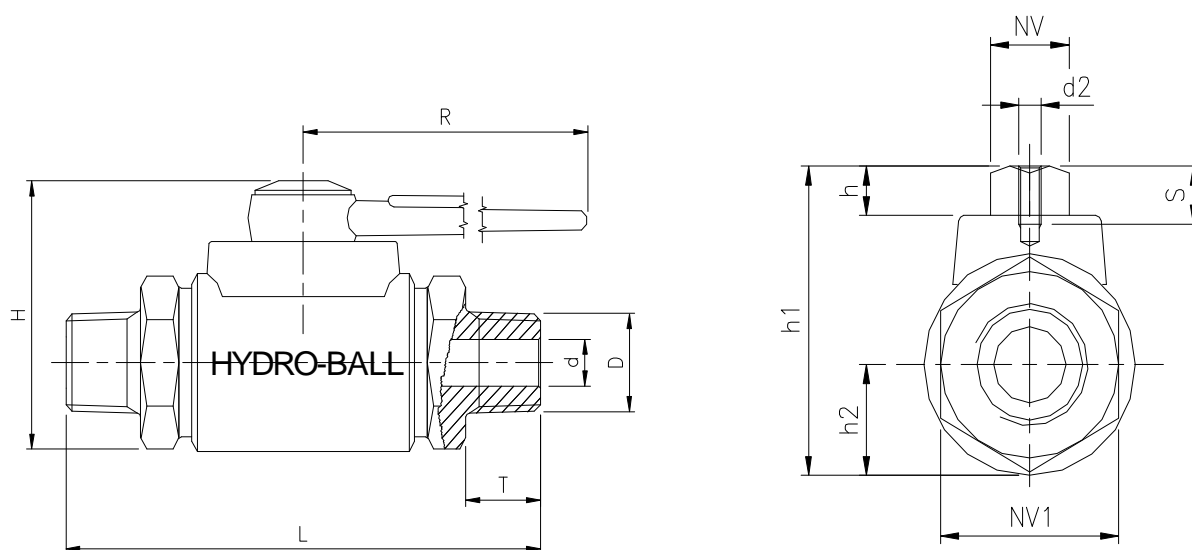

HYDRO-BALL® SERIE 62



Målskema

Med tilslutning UN, udvendigt NPT gevind, ANSI B1.20.1

D	d	DN	T	L	H	R	NV1	h1	h2	h	NV	S	d2	Kg/stk
1/4"NPT	6	6	14	92	48	135	27	43	15	6,5	8	8	M3	0,40
3/8"NPT	10	10	17,5	99	48	135	27	43	15	6,5	8	8	M3	0,44
1/2"NPT	13	15	17,5	111	60	160	32	55	19	8,5	10	10	M4	1,00
3/4"NPT	19	20	20	131	74	190	41	68	24	10	12	10	M5	1,50
1"NPT	25	25	22,9	155	86	215	50	80	28,5	12	14	10	M5	2,35