

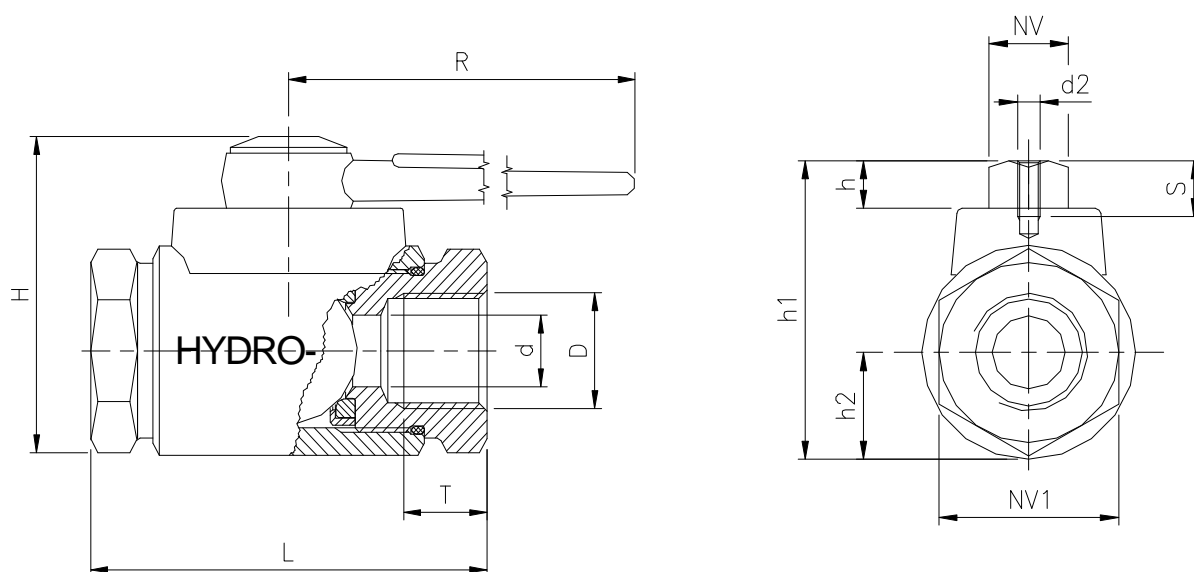

HYDRO-BALL® SERIE RR62



Målskema

Med tilslutning IN, indvendigt NPT gevind, ANSI B1.20.1

D	d	DN	T	L	H	R	NV1	h1	h2	h	NV	S	d2	Kg/stk
1/4"NPT	6	6	15	73	48	135	27	43	15	6,5	8	8	M3	0,42
3/8"NPT	10	10	15	76	48	138	27	43	15	6,5	8	8	M3	0,38
1/2"NPT	13	15	15	77	60	165	32	55	19	8,5	10	10	M4	0,60
3/4"NPT	19	20	18	92	74	190	41	68	24	10	12	10	M5	1,10
1"NPT	25	25	20	109	86	215	50	80	28,5	12	14	10	M5	1,75