

HSS-PM HSS-PM Line

Serie/Series 02120

Frese a **SEMIFINIRE** con spacco longitudinale
Semi-finishing cutters with longitudinal keyway

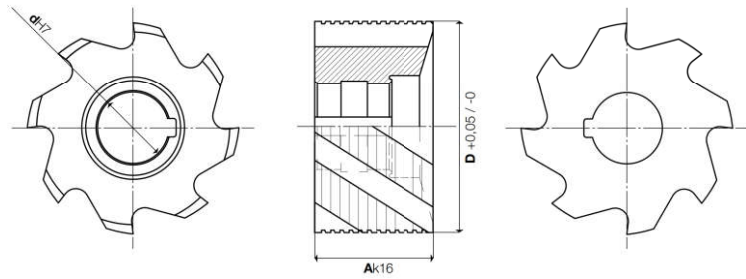
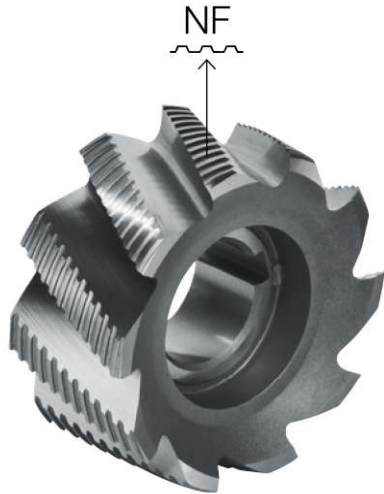

COATING Skin	λ° S 28	NF	DIN 841 ISO 2586	Z6÷14
------------------------	---------------------------	----	---------------------	-------

Cod. Art.	X-85 (PM Co 8,5%)	COATED	D +0.05 -0	Ak16	dH7	Z
021200300	CM	CMX	30	30	13	6
021200350	CM	CMX	35	35	16	6
021200400	CM	CMX	40	20	16	8
021200402	CM	CMX	40	40	16	6
021200500	CM	CMX	50	25	22	8
021200502	CM	CMX	50	50	22	8
021200600	CM	CMX	60	30	27	10
021200602	CM	CMX	60	60	27	10
021200750	CM	CMX	75	35	27	10
021200752	CM	CMX	75	75	27	10
021200900	CM	CMX	90	35	27	12
021201100	CM	CMX	110	35	32	12
021201300	CM	CMX	130	35	40	14
021201500	CM	CMX	150	40	40	14

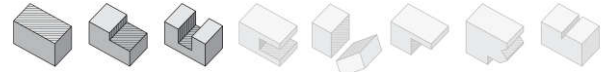

Serie/Series 02120

Frese a **SGROSSARE** con spacco longitudinale
Roughing cutters with longitudinal keyway

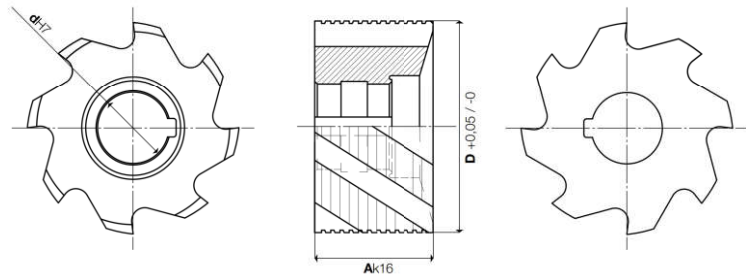
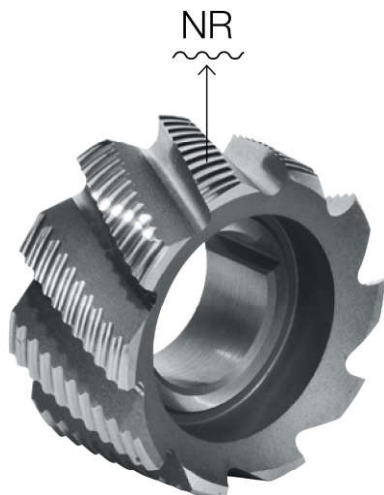

COATING Skin	λ° S 28	NR	DIN 841 ISO 2586	Z6÷14
------------------------	---------------------------	----	---------------------	-------

Cod. Art.	X-85 (PM Co 8,5%)	COATED	D +0.05 -0	Ak16	dH7	Z
021200301	CM	CMX	30	30	13	6
021200351	CM	CMX	35	35	16	6
021200401	CM	CMX	40	20	16	8
021200403	CM	CMX	40	40	16	6
021200501	CM	CMX	50	25	22	8
021200503	CM	CMX	50	50	22	8
021200601	CM	CMX	60	30	27	10
021200603	CM	CMX	60	60	27	10
021200751	CM	CMX	75	35	27	10
021200753	CM	CMX	75	75	27	10
021200901	CM	CMX	90	35	27	12
021201101	CM	CMX	110	35	32	12
021201301	CM	CMX	130	35	40	14
021201501	CM	CMX	150	40	40	14

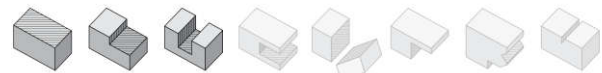

MATERIALI LAVORABILI / WORKPIECE MATERIALS

serie	TITANIO TITANIUM	HRSA HRSA	ACCIAI INOSSIDABILI STAINLESS STEELS	MATERIALI NON FERROSI NON FERROUS MATERIALS	LEGHE LEGGERE LIGHT ALLOYS	ACCIAI STEELS	GHISE CAST IRON
02120	●	●	●	○	○	●	●
02120	●	●	●	○	○	●	●