

HSS-PM HSS-PM Line

Serie/Series

06120

Frese ad angolo per utensili
Angular cutters for toolmaking

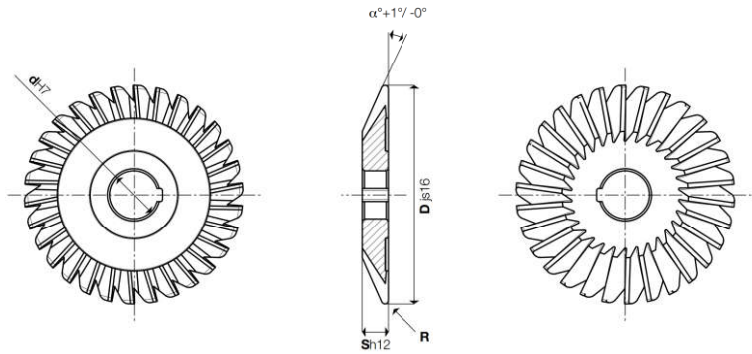

COATING	H	UNI 3910A DIN 1824A ISO	Z24÷30
Skin			

Cod. Art.	X-85 (PM Co. 8,5%)	COATED	Djs16	α° +1°/-0°	Sh12	dh7	R	Z
061201056 CM	CMX		56	18	6	16	1	26
061201080 CM	CMX		80	18	9	22	1,2	26
061201100 CM	CMX		100	18	12	22	1,6	30
061202056 CM	CMX		56	24	6	16	1	24
061202080 CM	CMX		80	24	9	22	1,2	26
061202100 CM	CMX		100	24	12	22	1,6	30
061203056 CM	CMX		56	30	6	16	1	24
061203080 CM	CMX		80	30	9	22	1,2	26
061203100 CM	CMX		100	30	12	22	1,6	30

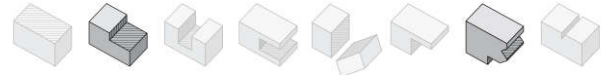

Serie/Series 06125

Frese ad angolo per utensili
Angular cutters for toolmaking

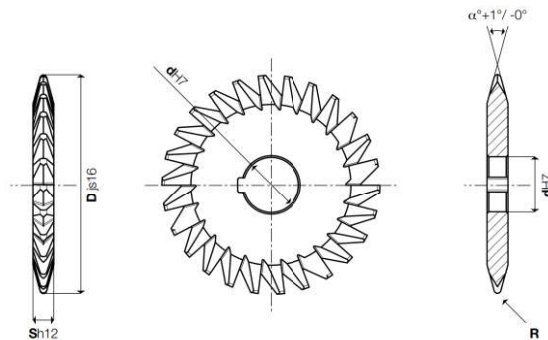

COATING	H	UNI 3910B DIN 1824B ISO 2586	Z26÷30
Skin			

Cod. Art.	X-85 (PM Co. 8,5%)	COATED	Djs16	α° +1°/-0°	Sh12	dh7	R	Z
061251863 CM	CMX		63	18	6	16	1	26
061251890 CM	CMX		90	18	10	22	1,6	30
061252463 CM	CMX		63	24	6	16	1	26
061252490 CM	CMX		90	24	10	22	1,6	30
061253063 CM	CMX		63	30	6	16	1	26
061253090 CM	CMX		90	30	10	22	1,6	30



MATERIALI LAVORABILI / WORKPIECE MATERIALS

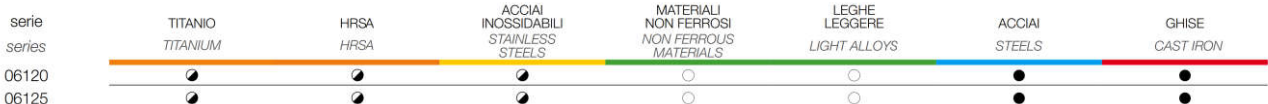

● consigliata/recommended ○ accettabile/acceptable ○ non consigliata/not recommended