

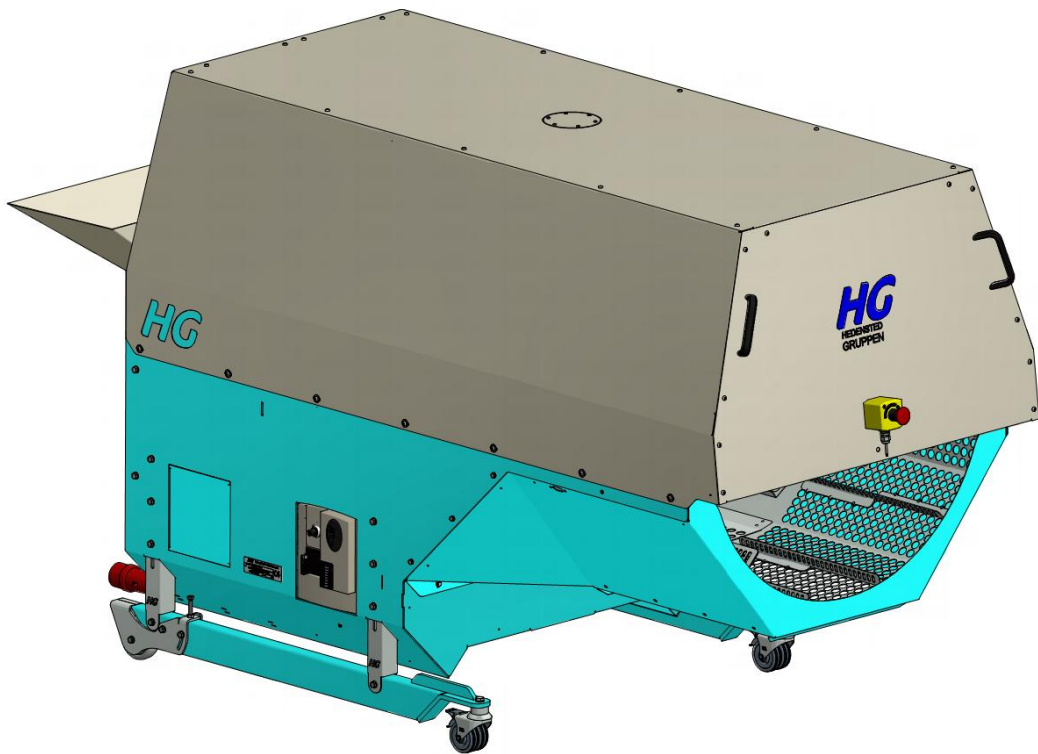

SPARE PARTS



HG Throughput drum 17

1. Table of contents.

1. Table of content.
2. Spare parts.
3. Electric diagrams.

A (1:5)

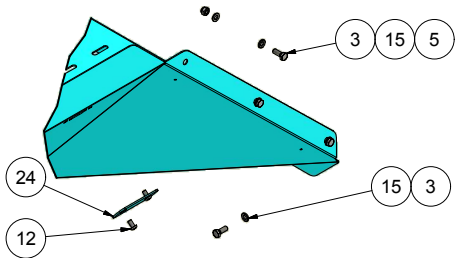

B (1:5)

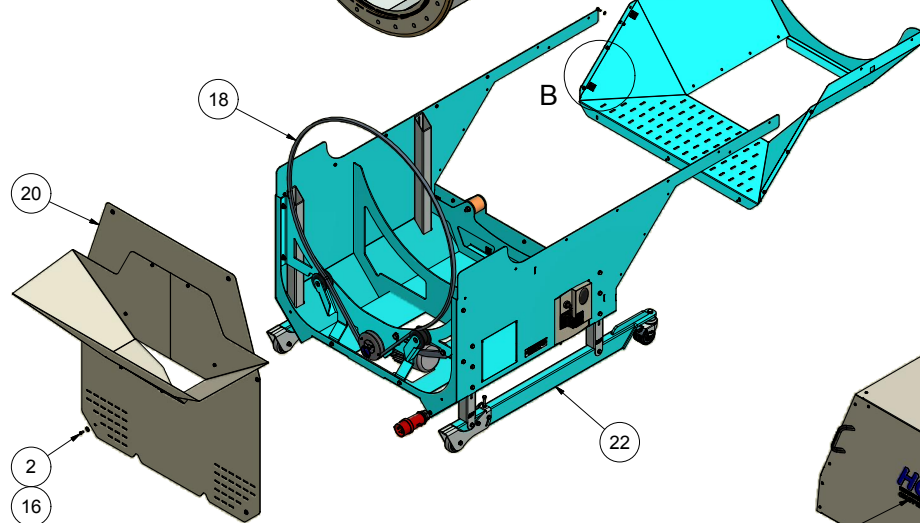
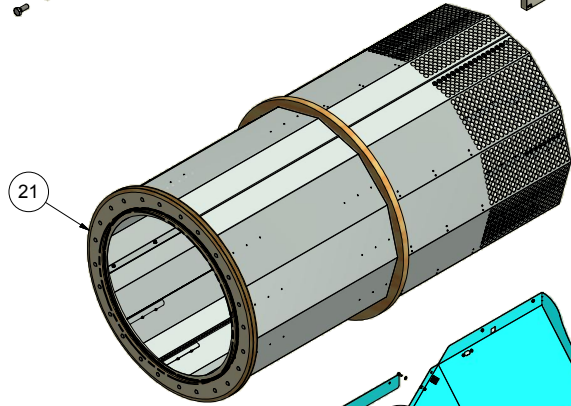
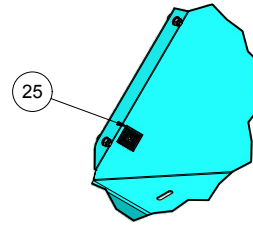

C (1:5)

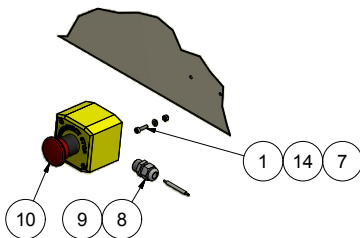

PARTS LIST

ITEM	QTY	PART NUMBER	DESCRIPTION
1	2	10704016	Hexagon cylinder head M4x16 A2
2	6	11406012	Hexagon bolt M6x12 FZB
3	9	11406016	Hexagon bolt M6x16 FZB
4	1	1508000	Nut M8 FZB
5	9	17906000	Self-locking nut M6 FZB
6	1	19767	HG Logo - big 205x108mm
7	2	19904000	Self-locking nut M4 A2
8	1	600460	Cable gland M16 Ø2,5-8
9	1	600470	Cable gland nut polyamid M16
10	1	600680	Emergency stop box. UK text
11	0,1 m	601000	Cable OZ 2x0,75mm² PVC
12	2	76005010	Buttonhead bolt M5x10 FZB
13	14	76006012	Buttonhead bolt M6x12 FZB
14	2	81804000	Washer M4 A2
15	18	82106000	Washer M6 FZB
16	20	82606000	Washer Ø6,4x18x1,6 FZB
17	1	M102291	Top cover assembly for drum
18	1	M102294	V-belt B124
19	1	M102298	Funnel for net end
20	1	M102365	Back cover assembly
21	1	M102372	Drum assembly
22	1	M102399	Frame drive assembly
23	1	M102421	Sticker for 190071
24	1	M102684	Cover
25	7	M201165	Base for cable black 25x25mm

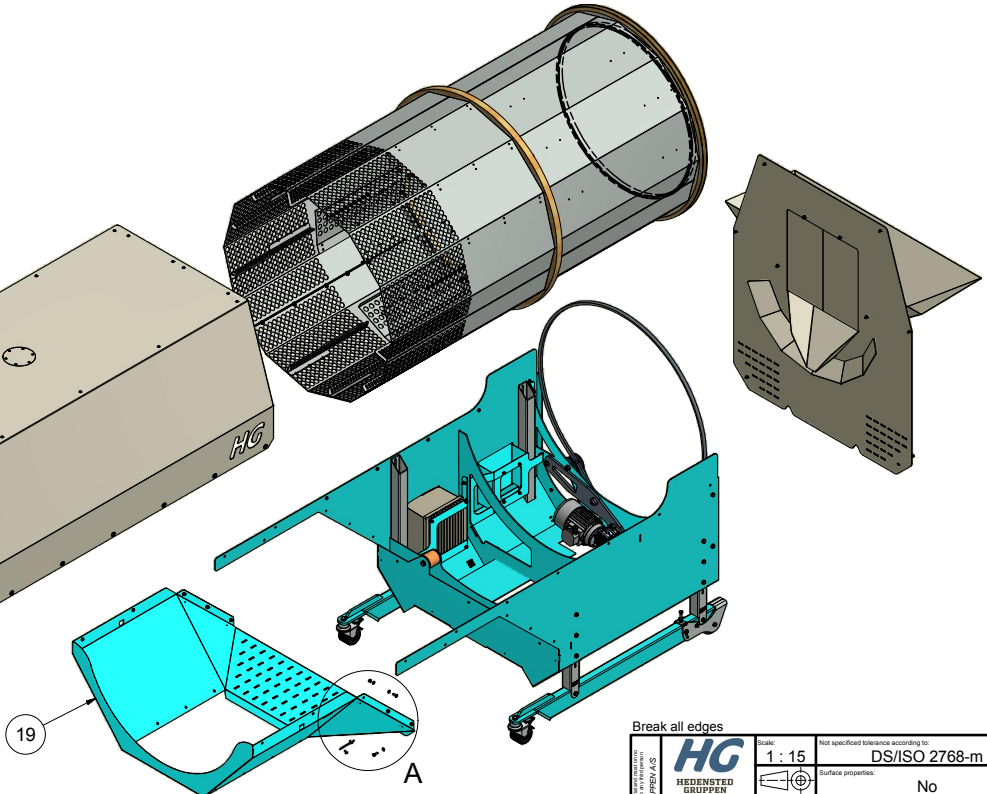

Break all edges

	Scale:	1 : 15	Not specified tolerance according to:	DS/ISO 2768-m	Sheet size:	A2
	Surface properties:	No	Material:		Sheet:	1 / 2
Part No.: 190071 Description 1: HG Throughput drum 17 Description 2: With adjustable speed						

Revision	Approved	Date	Revision Description
1	MBO	24-03-2017	Made

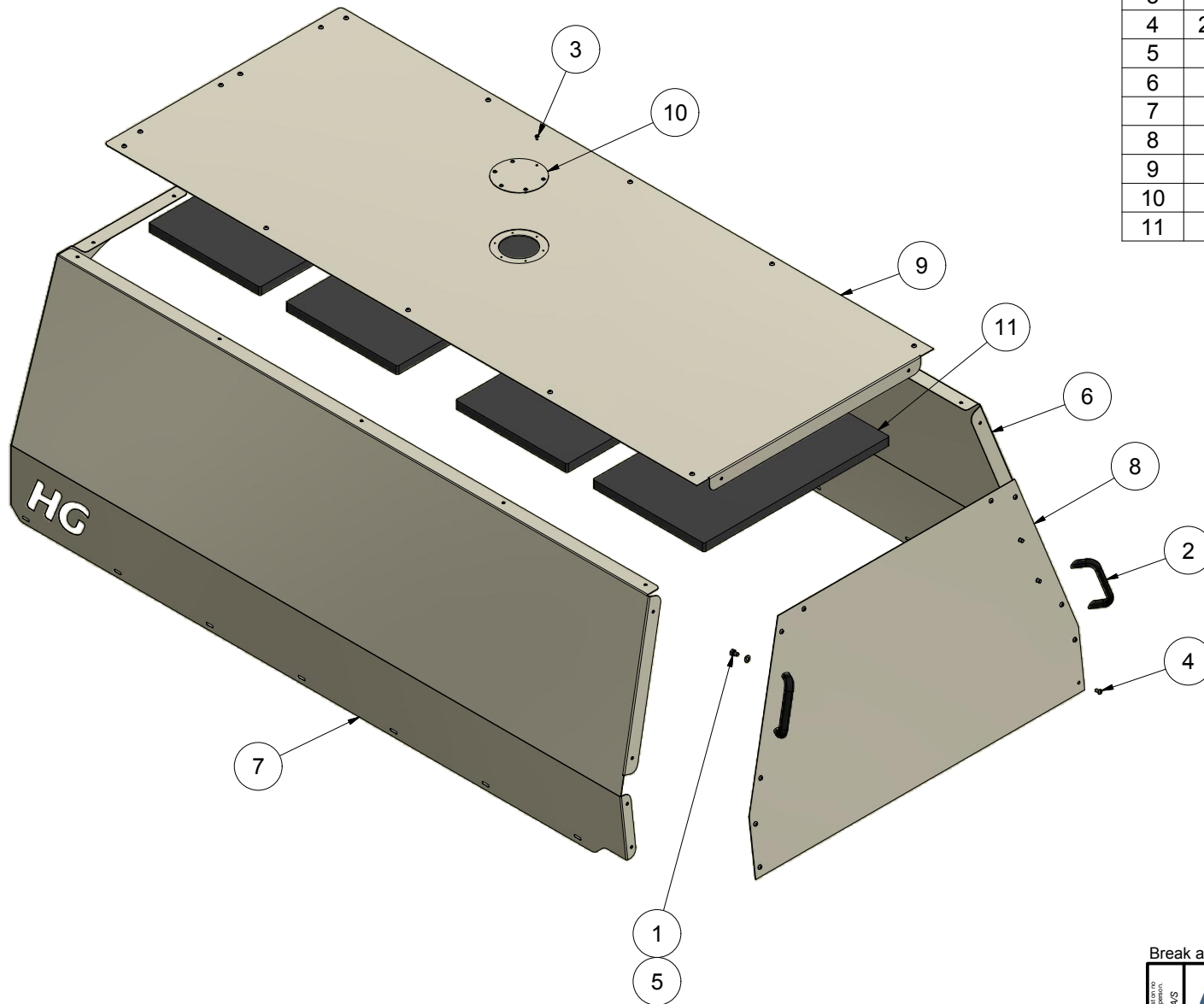

PARTS LIST			
ITEM	QTY	PART NUMBER	DESCRIPTION
1	4	11408012	Hexagon bolt M8x12 FZB
2	2	203945	Handle, U-shape 128 x 54 - M8 / 35°
3	6	76004008	Buttonhead bolt M4x8 FZB.ipt
4	24	76006012	Buttonhead bolt M6x12 FZB
5	4	82108000	Washer M8 FZB
6	1	M102292	Right top cover
7	1	M102293	Left top cover
8	1	M102563	End plate for cover
9	1	M102564	End Cover
10	1	M102572	Cover for spigot mount
11	4	M21276	Sound insulation- 12

Break all edges

This drawing is the property of HEDENSTED GRUPPEN AS. It is not to be copied, reproduced, or disseminated to any third person.	 HEDENSTED GRUPPEN	Scale:	1:10	Not specified tolerance according to:	DS/ISO 2768-m	Sheet size:	A3
	Part No.:	M102291	Material:	Surface properties:	No	Sheet:	1 / 2
	Description 1:						
	Description 2:						

Revision:	Approved	Date:	Revision Description
	MRH	13-09-2016	Made

PARTS LIST

ITEM	QTY	PART NUMBER	DESCRIPTION
1	3	11406016	Hexagon bolt M6x16 FZB
2	4	17906000	Self-locking nut M6 FZB
3	2	76006012	Buttonhead bolt M6x12 FZB
4	8	76006016	Buttonhead bolt M6x16 FZB
5	15	82106000	Washer M6 FZB
6	1	M102321	Skin funnel
7	1	M102363	Back cover funnel
8	1	M103138	Support bracket
9	1	M103139	Center top funnel
10	1	M103141	Left top funnel
11	1	M103142	Right top funnel
12	1	M103145	Service hole cover
13	28	M201095	Blind rivet Ø3,2x10 (5-7)

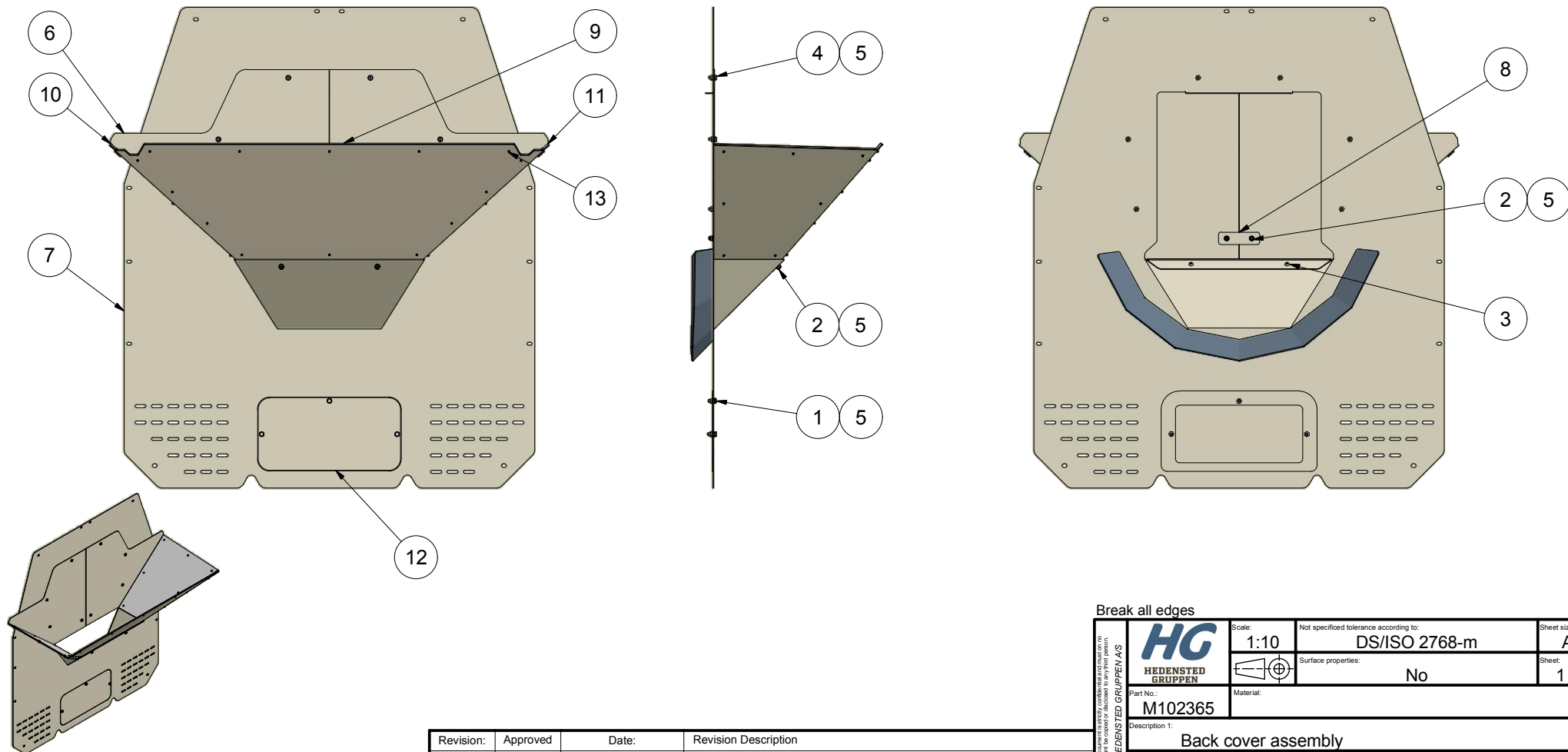

Break all edges

This drawing is property of HEDENSTED GRUPPEN A/S. It is not to be copied or disclosed to any third person.		Scale: 1:10	Not specified tolerance according to: DS/ISO 2768-m	Sheet size: A3
	HEDENSTED GRUPPEN A/S		Surface properties: No	Sheet: 1/1
	Part No.: M102365	Material:		
	Description 1: Back cover assembly			
Description 2:				

Revision:	Approved	Date:	Revision Description
4	KKS	03-04-2018	Parts updated

PARTS LIST			
ITEM	QTY	PART NUMBER	DESCRIPTION
1	85	17906000	Self-locking nut M6 FZB
2	48	64406045	Cup head square neck bolt M6x40 FZB
3	33	76006012	Buttonhead bolt M6x12 FZB
4	81	82106000	Washer M6 FZB
5	8	82606000	Washer Ø6,4x18x1,6 FZB
6	2,4 m	M102095	Brush for groove H25x8x8
7	9	M102325	Tumbler beam - long
8	1	M102355	Drive ring for drum
9	1	M102356	Drum ring
10	3	M102359	Tumbler plate
11	3	M102414	Front net assembly

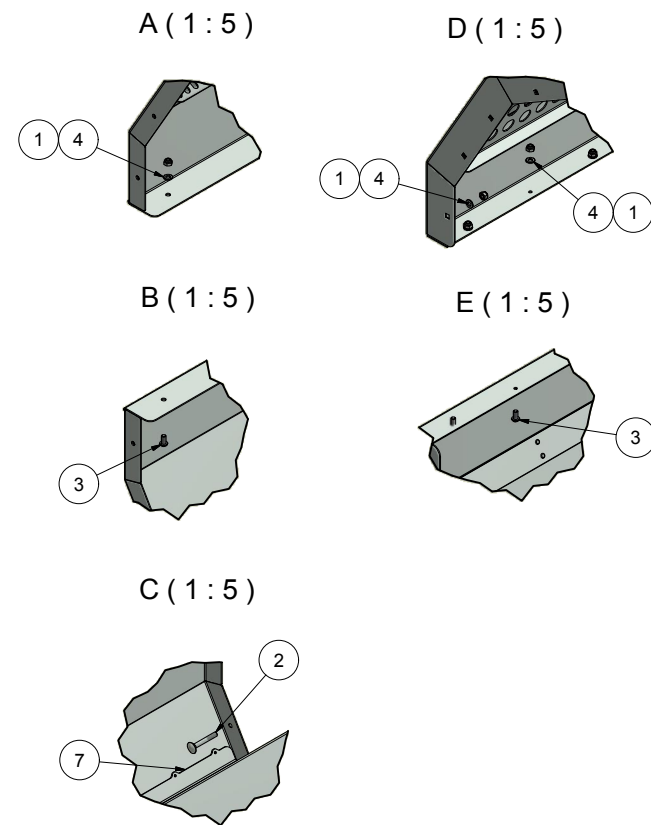
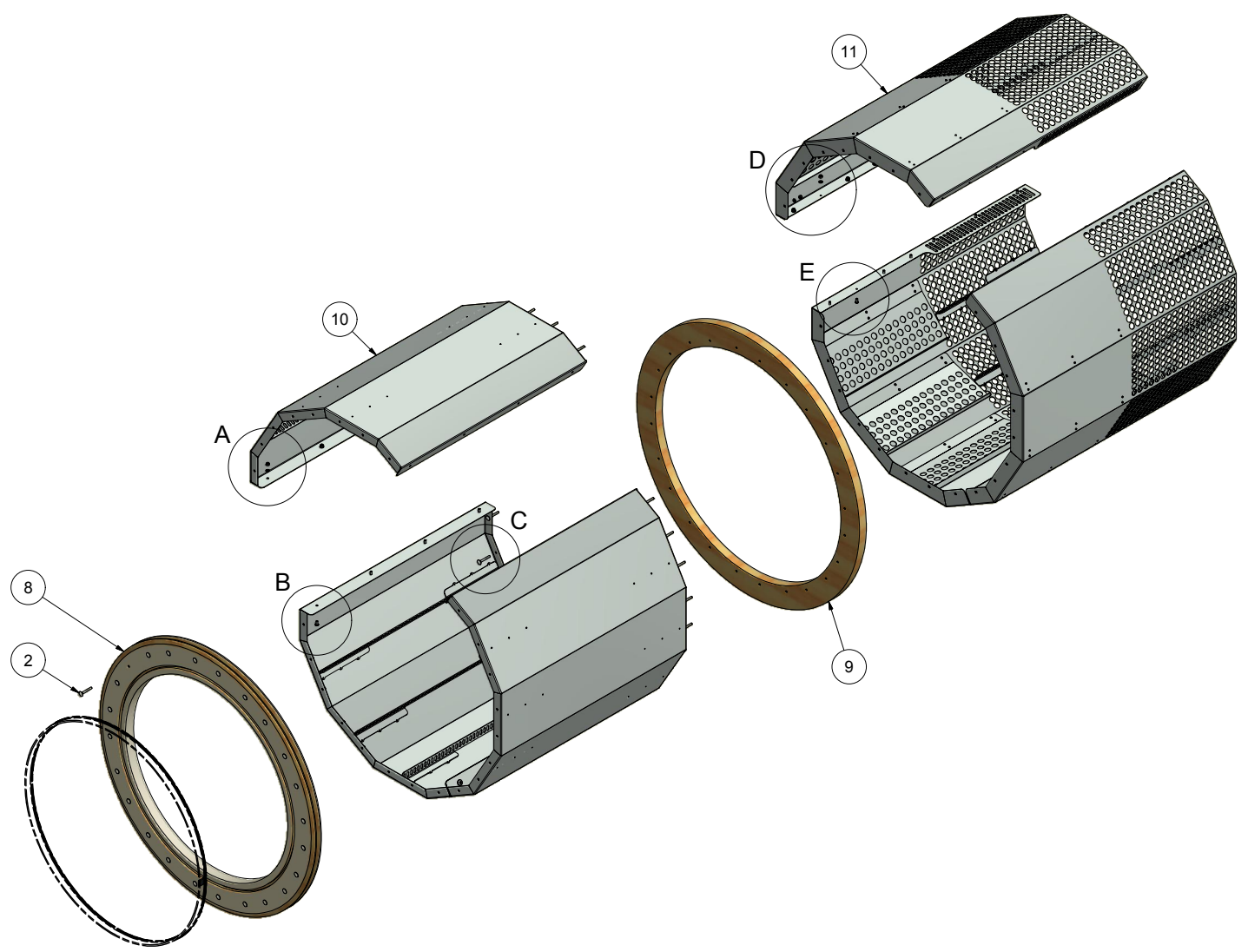



Break all edges			
 HEIDENSTEDT GRUPPEN A/S	Scale:	Not specified tolerance according to:	Sheet size:
	1 : 10	DS/ISO 2768-m	A2
Part No.:	Material:	Surface properties:	Sheet:
M102372		No	1 / 2
Description 1: Drum assembly			
Description 2:			

Revision:	Approved	Date:	Revision Description
1	MBO	27-03-2017	Made

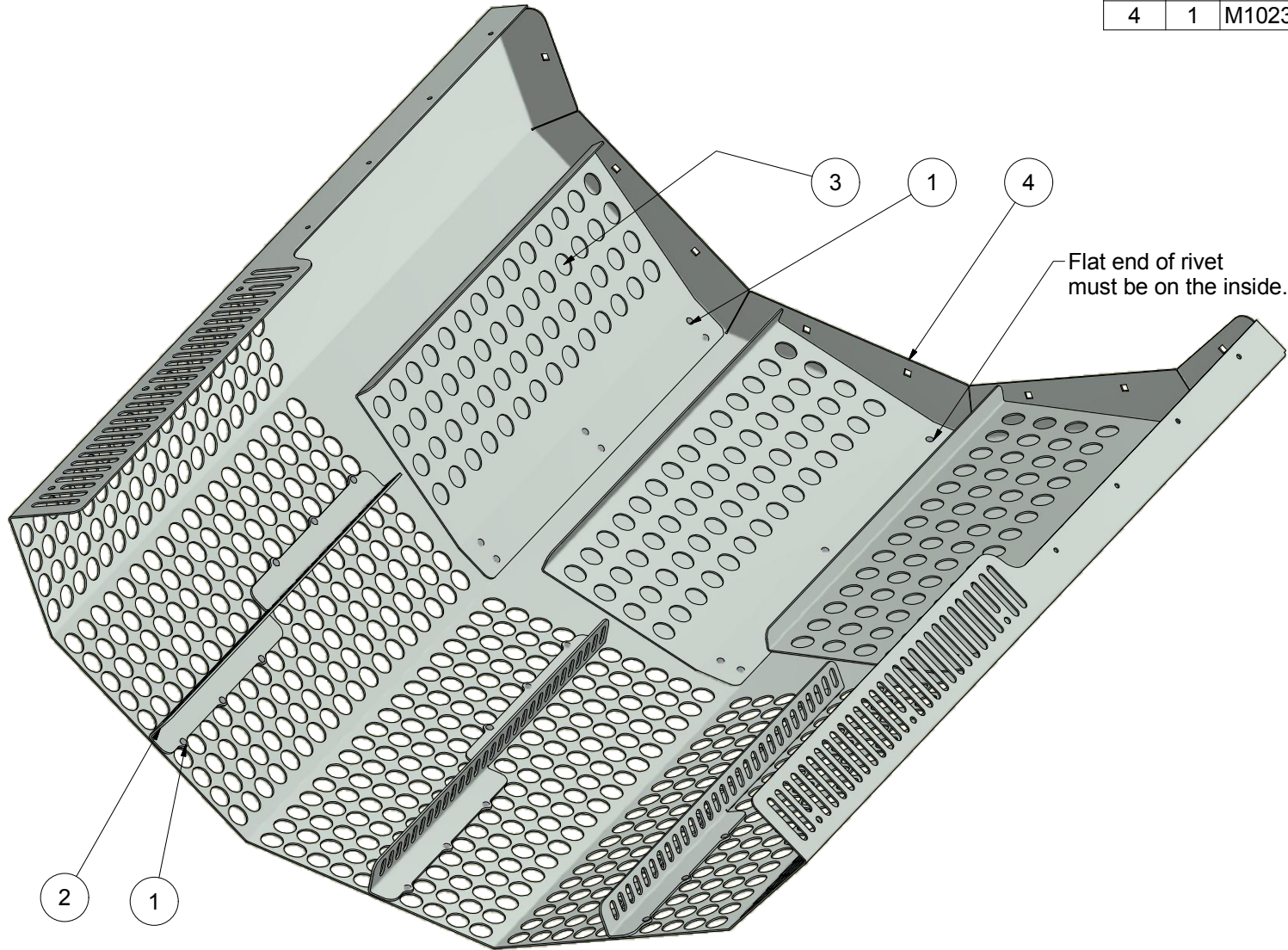
PARTS LIST			
ITEM	QTY	PART NUMBER	DESCRIPTION
1	36	7003206	Blind rivet Ø3,2x6 (2,5-3,5)
2	3	M102352	Tumbler beam
3	3	M102353	Tumbler plate
4	1	M102357	Net plate for drum



Break all edges

The information on this drawing is confidential and intended for internal use only. It is not to be copied or disclosed to any third party.	 HEDENSTED GRUPPEN A/S	Scale: 1 : 4	Not specified tolerance according to: DS/ISO 2768-m	Sheet size: A3
			Surface properties: No	Sheet: 1 / 1
	Part No.: M102414	Material:		
	Description 1: Front net assmeby			
Description 2:				

Revision:	Approved	Date:	Revision Description
1	MRH	08-09-2016	Made

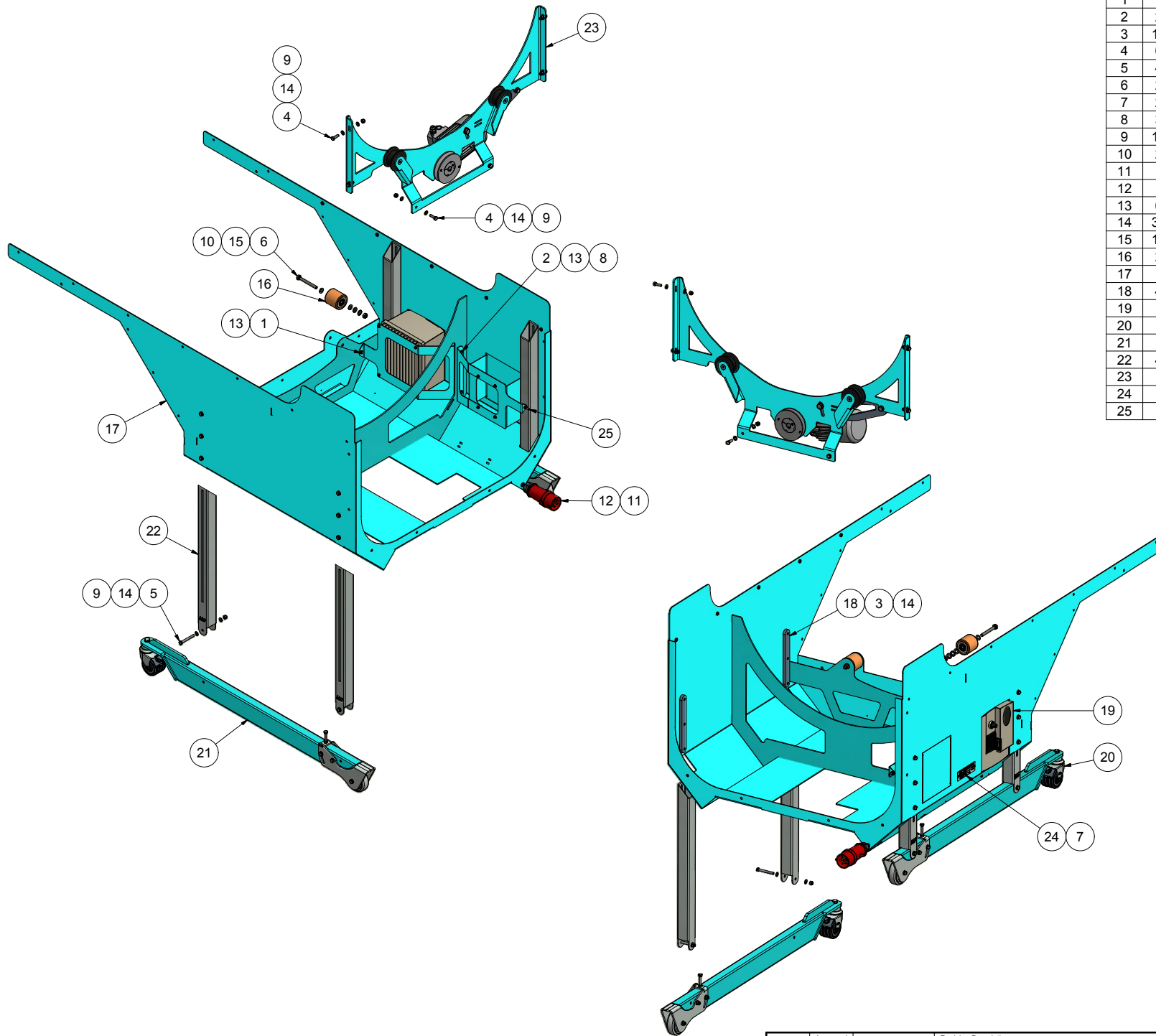

PARTS LIST			
ITEM	QTY	PART NUMBER	DESCRIPTION
1	1	11406016	Hexagon bolt M6x16 FZB
2	2	11406025	Hexagon bolt M6x25 FZB
3	12	11408020	Hexagon bolt M8x20 FZB
4	6	11408025	Hexagon bolt M8x25 FZB
5	4	11408065	Hexagon bolt M8x65 FZB
6	2	11410090	Hexagon bolt M10x90 FZB
7	2	140993	Blind rivet Ø3,2x6 (2,5-3,5)
8	3	17906000	Self-locking nut M6 FZB
9	10	17908000	Self-locking nut M8 FZB
10	2	17910000	Self-locking nut M10 FZB
11	1	33068	Rubber bushing ø9 x 13mm
12	1	50171	CEE Plug male 5P/16A/400V Phase inverter
13	6	82106000	Washer M6 FZB
14	32	82108000	Washer M8 FZB
15	10	82110000	Washer M10 FZB
16	2	M102065	Wheel Ø60x60xØ10
17	1	M102297	Frame for Drum
18	4	M102302	Lock plate for legs
19	1	M102366	Adjustable drive for drum
20	1	M102367	Left Wheel beam assembly
21	1	M102368	Right beam assembly
22	4	M102394	Leg for wheel beam
23	1	M102398	Drum drive assembly
24	1	M102422	ID plate for Skin tumbler
25	1	M102577	Blanking Cover for Motor Protection

Break all edges			
	Scale:	Not specified tolerance according to:	Sheet size:
	1 : 10	DS/ISO 2768-m	A2
HEIDENSTEDT GRUPPEN Part No.: M102399	Surface properties:	No	Sheet: 1 / 2
	Material:		
Description 1: Frame drive assembly			
Description 2:			

Revision:	Approved	Date:	Revision Description
1	MBO	22-03-2017	Made

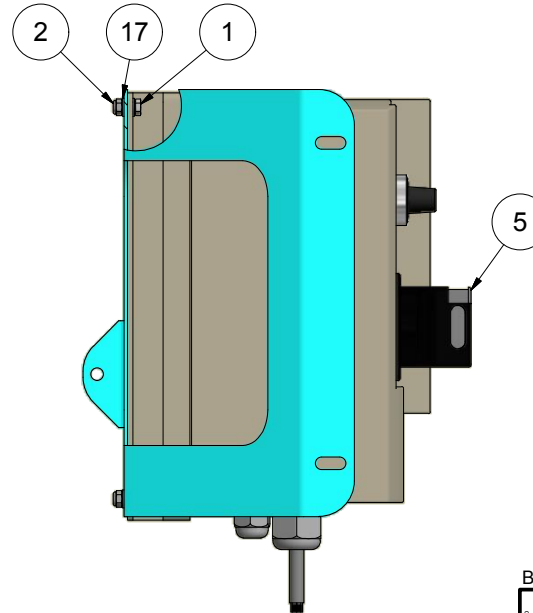
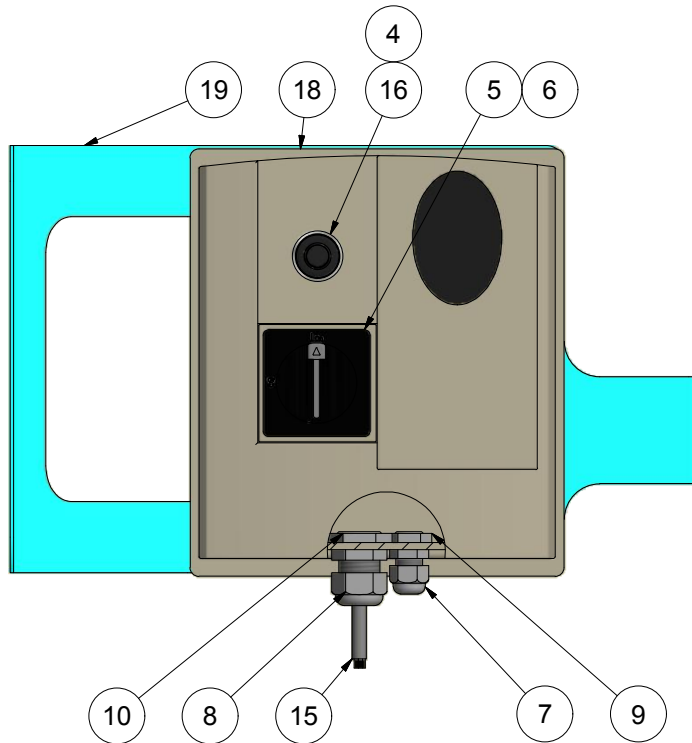
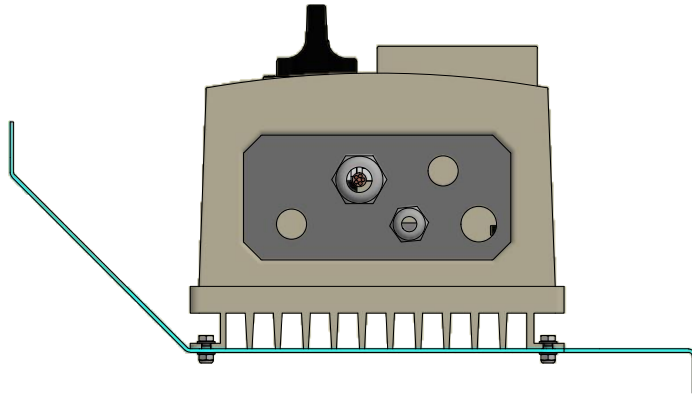

PARTS LIST			
ITEM	QTY	PART NUMBER	DESCRIPTION
1	4	11405012	Hexagon bolt M5x12 FZB
2	4	17905000	Self-locking nut M5 FZB
3	1,5 m	197510	Cable CY-JZ 4x0,75mm ² PVC w/screen
4	1	201107	Potentiometer type 4688705 10K ohm ø6 shaft
5	1	600358	Main switch VBF-01 20A 3P Black
6	1	600359	Main switch zero terminal VZ-11
7	1	600460	Cable gland M16 Ø2,5-8
8	1	600465	Cable gland M25 Ø7-14
9	1	600470	Cable gland nut polyamid M16
10	1	600480	Cable gland nut polyamid M25
11	4	600532	Pin double 0,75mm ² White isolation
12	15	600545	Pin 2,5mm ² Blue isolation (on strip)
13	4	600625	Cable shoe 0,5-1,5mm ² x Ø4 Red isolation
14	2	600630	Cable shoe 1,5-2,5mm ² x Ø4 Blue isolation
15	5,0 m	600640	Cable JZ 5x2,5mm ² PVC
16	1	600655	Potentiometer element Ø6 ZB4BD912
17	8	82105900	Washer M5 FZB
18	1	M102323	Altivar Frq converter 0,37kW 1/230v
19	1	M102340	Bracket for converter

Break all edges

The information on this drawing is confidential and may be used for any purpose without the prior written consent of HEDENSTED GRUPPEN AS.		Scale:	1 : 3	Not specified tolerance according to:	DS/ISO 2768-m	Sheet size:	A3		
	HEDENSTED GRUPPEN			Surface properties:	No	Sheet:	1 / 1		
	Part No.:	M102366						Material:	
	Description 1:	Adjustable drive for drum						Description 2:	0,37kW 1/230v converter

Revision:	Approved	Date:	Revision Description
1	MBO	28-03-2017	Made

PARTS LIST			
ITEM	QTY	PART NUMBER	DESCRIPTION
1	1	11408050	Hexagon bolt M8x50 FZB
2	3	11408065	Hexagon bolt M8x65 FZB
3	1	11410060	Hexagon bolt M10x60 FZB
4	1	1508000	Nut M8 FZB
5	3	17908000	Self-locking nut M8 FZB
6	1	17910000	Self-locking nut M10 FZB
7	1	18998	Wheel for through put drum
8	6	82108000	Washer M8 FZB
9	2	82110000	Washer M10 FZB
10	1	M102304	Wheek mount 1
11	1	M102305	Wheel mount 2
12	1	M102307	Wheel spacer
13	1	M102310	Wheel dobbel Ø75 H101
14	1	M102311	Leg beam assembly

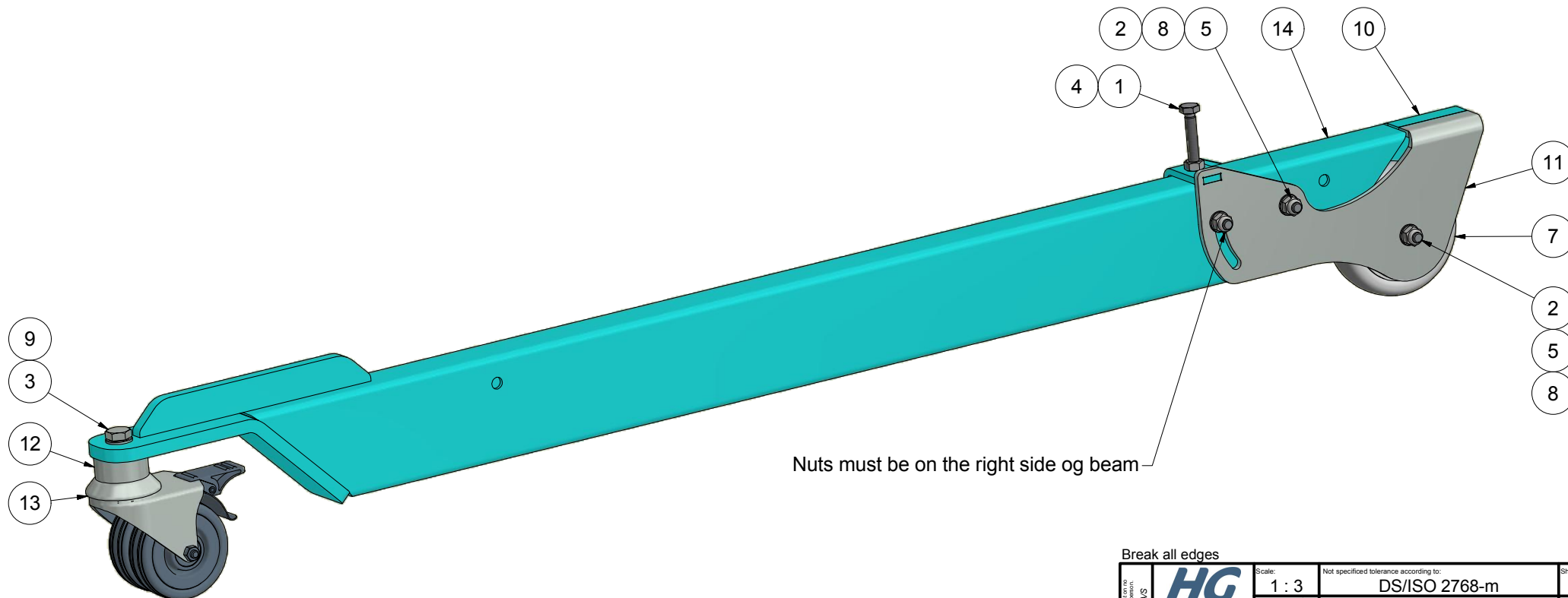

Break all edges

This drawing is the property of HEDENSTED GRUPPEN AS. It is not to be copied, reproduced, or disseminated to any third person.	 HEDENSTED GRUPPEN AS	Scale: 1 : 3	Not specified tolerance according to: DS/ISO 2768-m	Sheet size: A3
	Part No.: M102367		Surface properties: No	Sheet: 1 / 1
	Description 1: Left Wheel beam assembly			
	Description 2:			

Revision:	Approved	Date:	Revision Description
1	MBO	27-03-2017	Made

PARTS LIST

ITEM	QTY	PART NUMBER	DESCRIPTION
1	1	11408050	Hexagon bolt M8x50 FZB
2	3	11408065	Hexagon bolt M8x65 FZB
3	1	11410060	Hexagon bolt M10x60 FZB
4	1	1508000	Nut M8 FZB
5	3	17908000	Self-locking nut M8 FZB
6	1	17910000	Self-locking nut M10 FZB
7	1	18998	Wheel for through put drum
8	6	82108000	Washer M8 FZB
9	2	82110000	Washer M10 FZB
10	1	M102304	Wheek mount 1
11	1	M102305	Wheel mount 2
12	1	M102307	Wheel spacer
13	1	M102310	Wheel dobbel Ø75 H101
14	1	M102311	Leg beam assembly

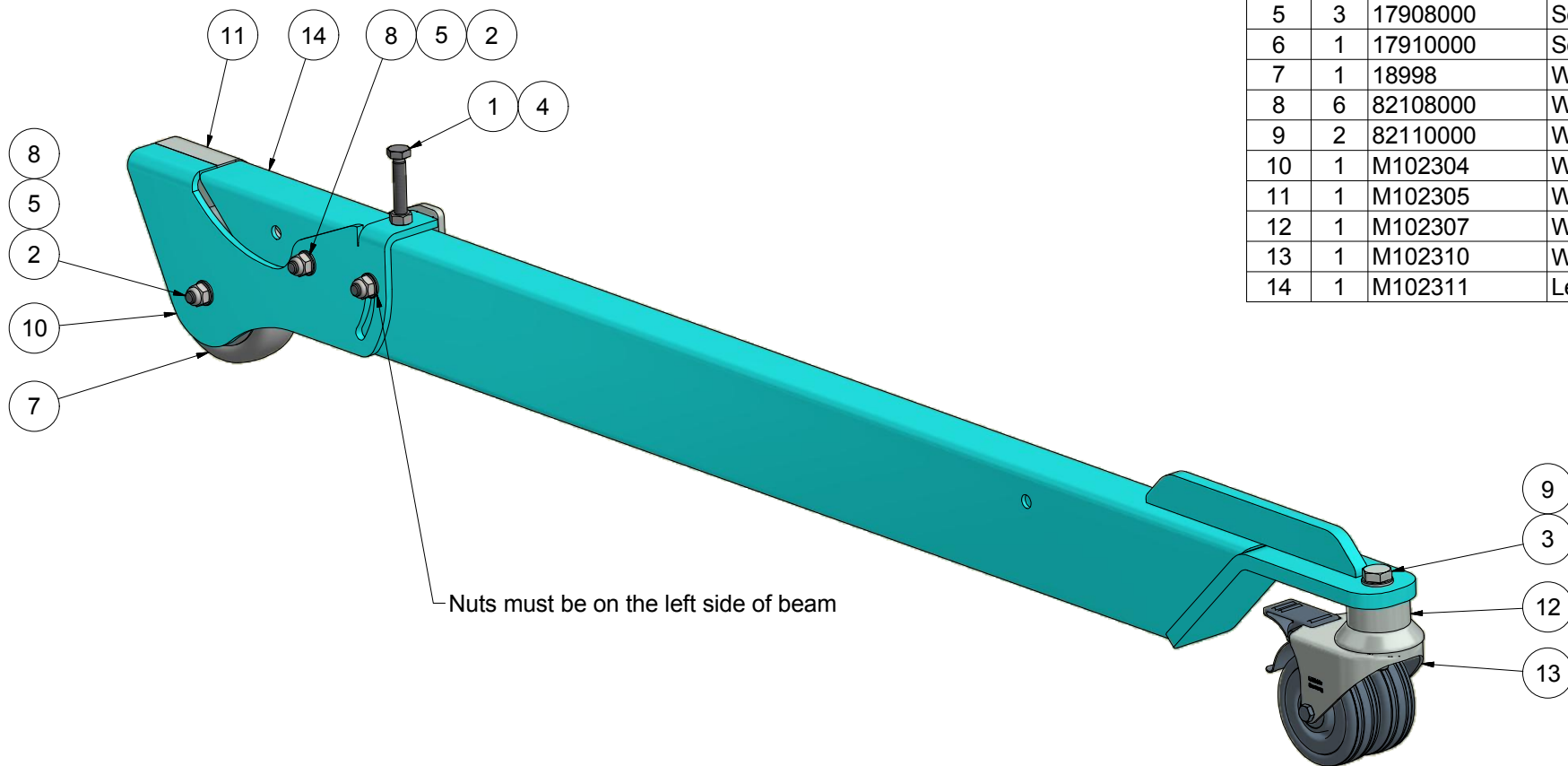

Break all edges

The information on this drawing is the property of HEDENSTED GRUPPEN AS. It is not to be copied or disclosed to any third person.	 HEDENSTED GRUPPEN AS	Scale:	Not specified tolerance according to:	Sheet size:
		1 : 3	DS/ISO 2768-m	A3
		Surface properties:		Sheet:
		No		1 / 1
Part No.:		Material:		
M102368				
Description 1:				
Right beam assembly				
Description 2:				

Revision:	Approved	Date:	Revision Description
1	MBO	27-03-2017	Made

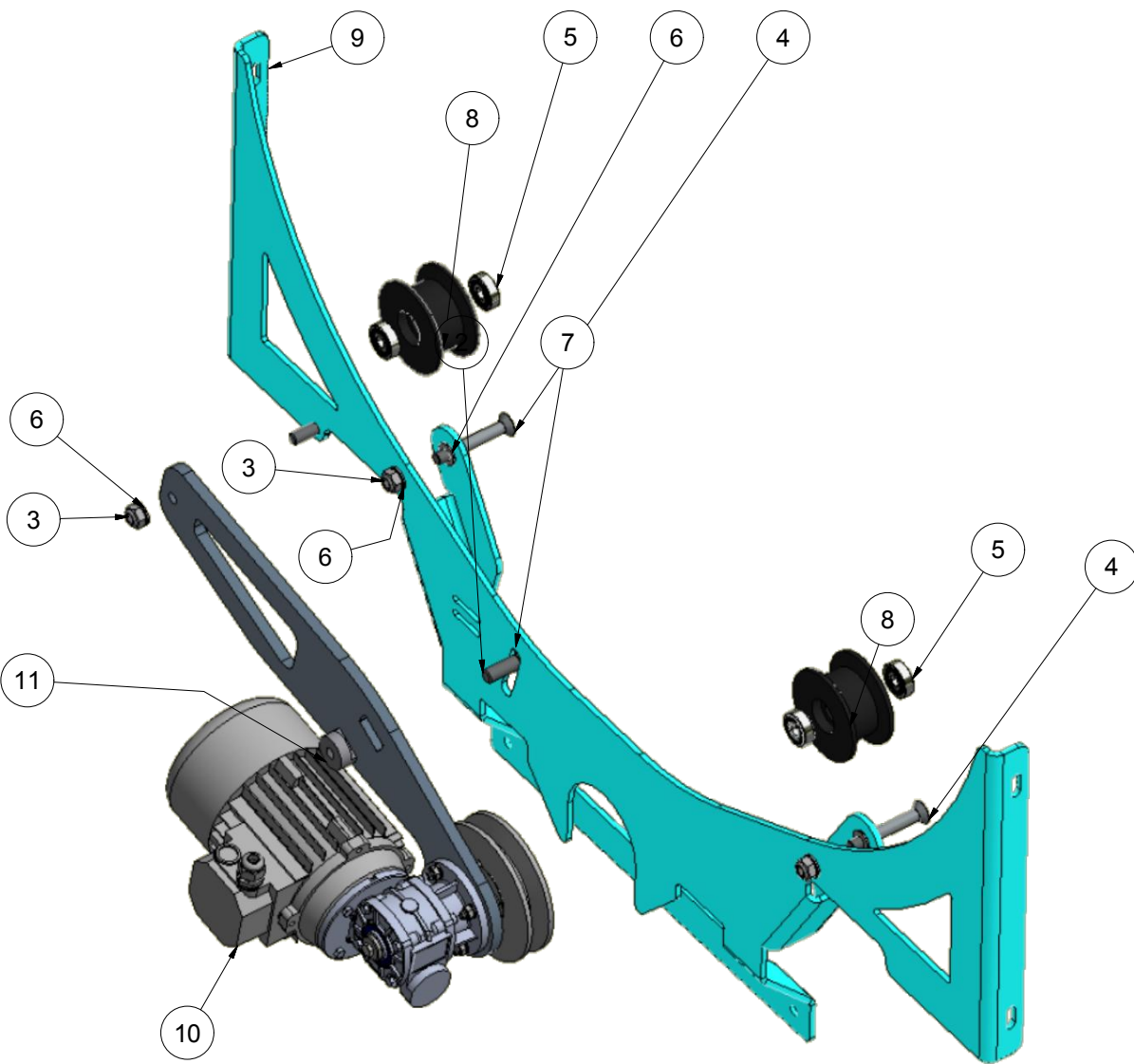

PARTS LIST			
ITEM	QTY	PART NUMBER	DESCRIPTION
1	1	11410030	Hexagon bolt M10x30 FZB
2	1	11412035	Hexagon bolt M12x35 FZB
3	3	17910000	Self-locking nut M10 FZB
4	2	20410070	Hexagon countersunk head M10x70 FZB
5	4	473033	Bearing 6200 2RS1 Ø10-30
6	8	82110000	Washer M10 FZB
7	1	82112000	Washer M12 FZB
8	2	M102354	Wheel for drive ring
9	1	M102358	Drum support bracket
10	1	M102364	Drive assembly
11	1	M102371	Nut for motor

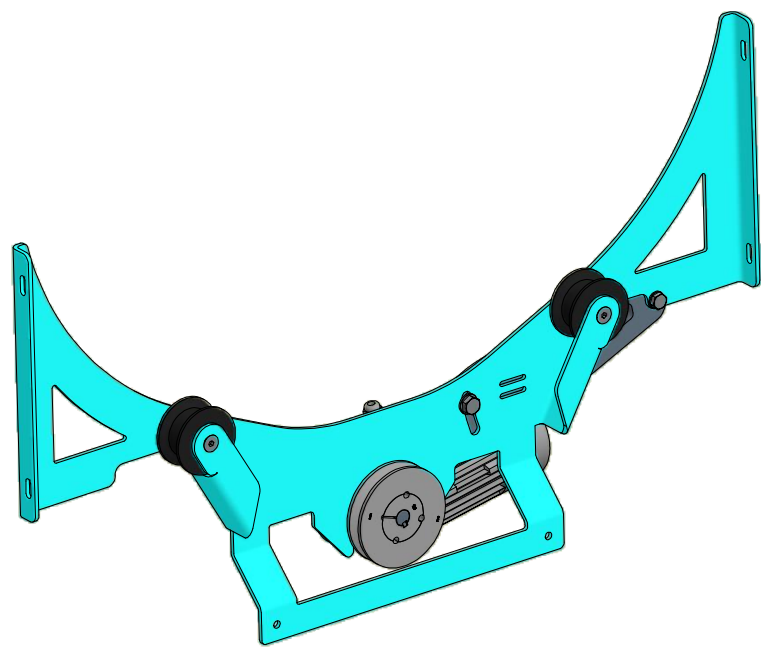

Revision:	Approved	Date:	Revision Description
1	MBO	22-03-2017	Made

Break all edges

 HG HEDENSTED GRUPPEN	Scale:	Not specified tolerance according to:	Sheet size:
	1 : 4	DS/ISO 2768-m	A3
	Surface properties:	No	
	Part No.:	M102398	
Material:			
Description 1: Drum drive assembly			
Description 2:			

This drawing is the property of HEDENSTED GRUPPEN AS. It is not to be copied or disclosed to any third person.

PARTS LIST

ITEM	QTY	PART NUMBER	DESCRIPTION
1	1	M102370	Motor plate
2	1	190086	Vee-belt pully Ø112-1-B Ø19
3	1	M102369	Shaft for drun drive
4	1	30960	Key 5x5x32mm DIN-6885A
5	1	201150	Key 6x6x32mm DIN-6885A
6	2	4206000	Washer type TBR SB Ø6,4x22x4 FZB
7	2	11406020	Hexagon bolt M6x20 FZB
8	1	M102300	Gearmotor 1:10 0,25kW B14 IEC63
9	8	82106000	Washer M6 FZB
10	4	17906000	Self-locking nut M6 FZB
11	4	11406030	Hexagon bolt M6x30 FZB

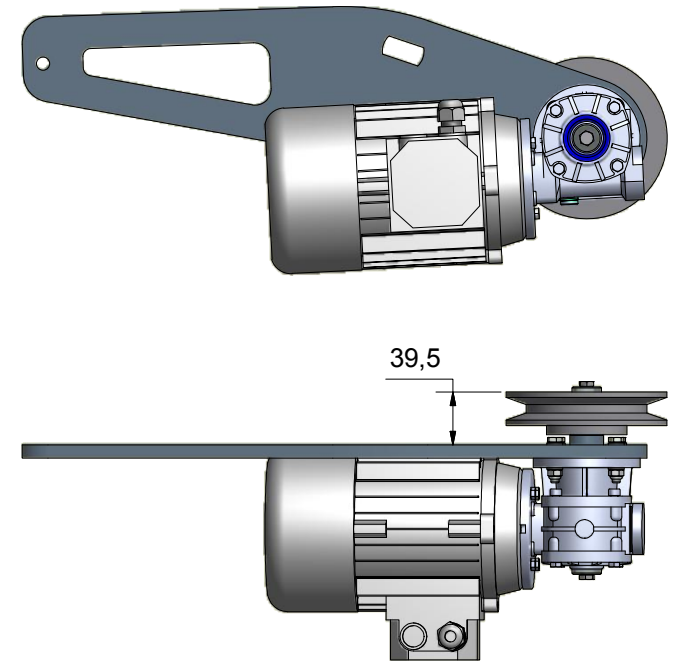
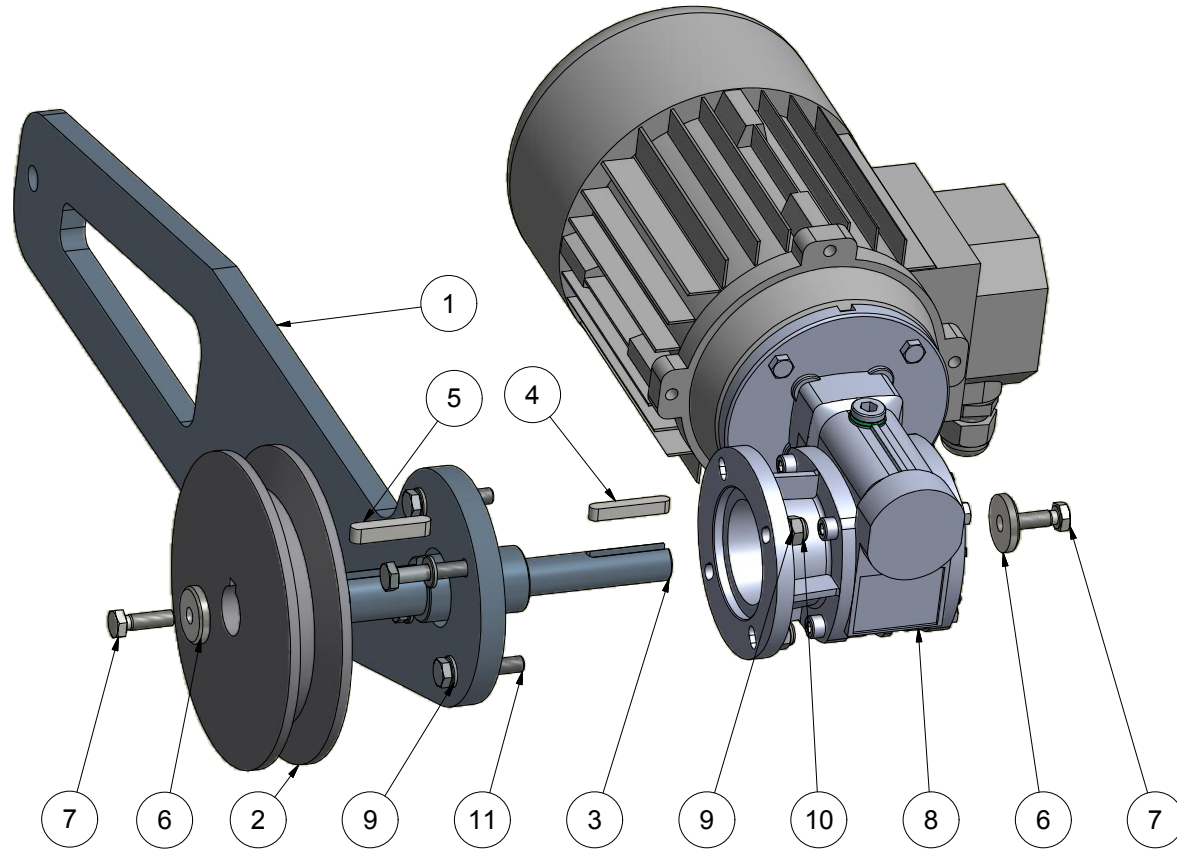

Break all edges

This drawing is the property of HEDENSTED GRUPPEN AS. It is not to be copied, reproduced, or disseminated to any third person.	 HEDENSTED GRUPPEN	Scale: 1 : 2	Not specified tolerance according to: DS/ISO 2768-m	Sheet size: A3
	Part No.: M102364	Material:	Surface properties: No	Sheet: 1/1
	Description 1: Drive assembly			
	Description 2:			

Revision:	Approved	Date:	Revision Description
1	MRH	14-09-2016	Made

PARTS LIST

ITEM	QTY	PART NUMBER	DESCRIPTION
1	4	11405012	Hexagon bolt M5x12 FZB
2	1	11406025	Hexagon bolt M6x25 FZB
3	4	17905000	Self-locking nut M5 FZB
4	1	17906000	Self-locking nut M6 FZB
5	8	82105900	Washer M5 FZB
6	2	82106000	Washer M6 FZB
7	1	M102575	Bracket for Motor Protection
8	1	M102576	Blanking Cover for Motor Protection

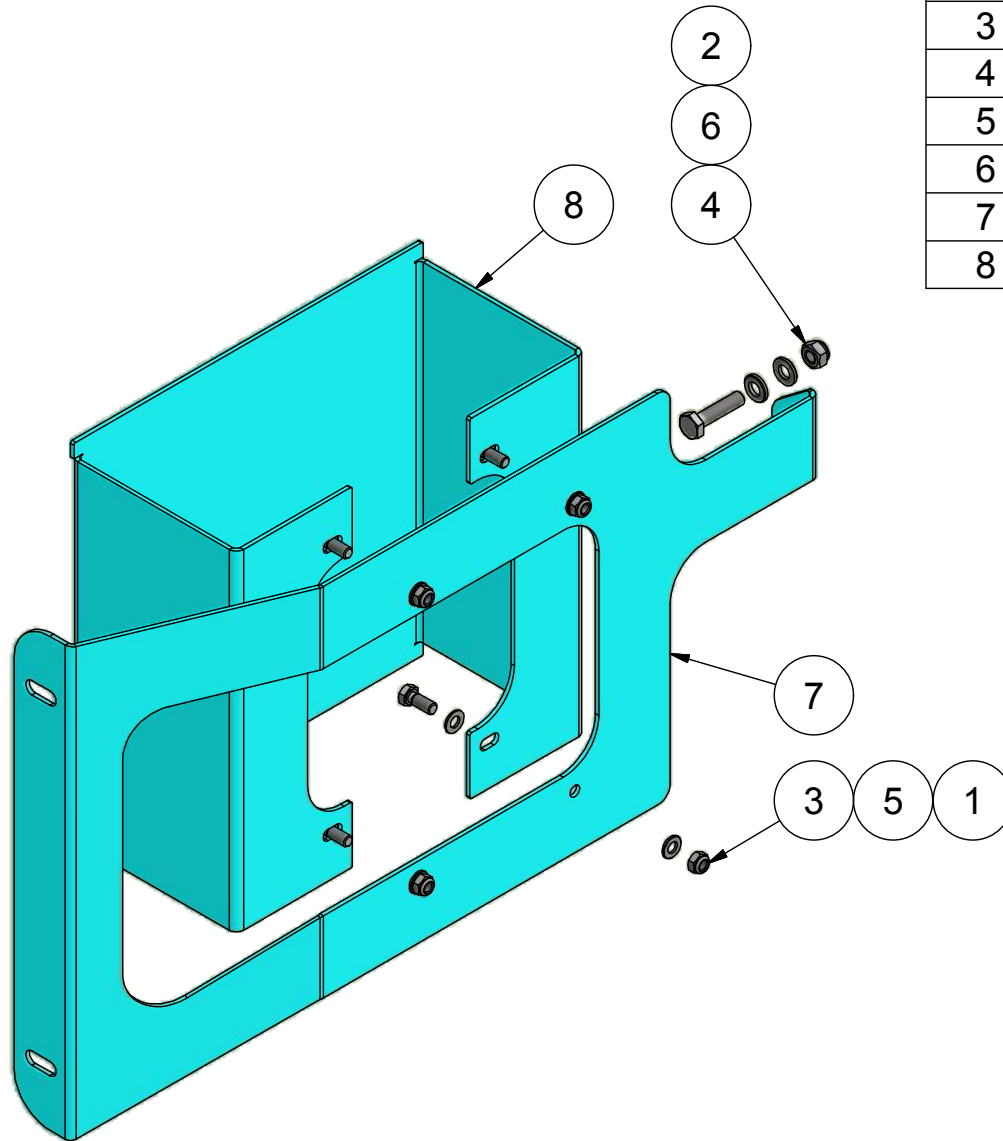

Break all edges

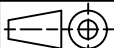
This document is strictly confidential and must not be copied or disclosed to any third person. HEDENSTED GRUPPEN A/S	 HEDENSTED GRUPPEN	Scale: 1 : 3	Not specified tolerance according to: DS/ISO 2768-m	Sheet size: A4
			Surface properties: No	Sheet: 1 / 1
	Part No.: M102577	Material:		
	Description 1: Blanking Cover for Motor Protection			
Description 2:				

Revision:	Approved	Date:	Revision Description
1	MBO	24-03-2017	Made

Customer: Hedensted Gruppen A/S

Project: Throughput drum 16 - 2016_01

Hedensted Gruppen A/S
Vejlevej 15a
DK-8722 Hedensted
TLF: 75 89 12 44
FAX: 75 89 11 80



Tlf. 75 64 18 99 - vs-automatic.dk
En del af **TS-GRUPPEN** - Danmarks stærkeste El & Energi Installatører

Project title: Throughput drum 16 - 2016_01

Customer: Hedensted Gruppen A/S

Filename: Throughpart drum 16 - 2016_01

Last printed: 30-05-2017

07:52:39

Case no.: Throughpar

Last checked: 16-05-2017 12:34:24

Page: A

of 11

Index

Information	D
03-05-2017 13:58:42	
Declaration of incorporation	E
03-05-2017 14:00:32	
CONVERTER MOTOR	1
16-05-2017 12:37:54	
Cable list	10
16-05-2017 13:13:10	
Part list	11
16-05-2017 13:13:10	

Information

WIRE IDENTIFICATION:

The wire is identified with the terminal number of the component.

WIRE COLOUR:

MAIN CIRCUIT:	Phase	Black
	Neutral	Light blue
DC CONTROL CIRCUIT:	24VDC	Dark blue
	0VDC	White

THE FOLLOWING COLOUR ID IS TAKEN FROM DS/EN 60757

BK	BLACK
BN	BROWN
RD	RED
OG	ORANGE
YE	YELLOW
GN	GREEN
BU	BLUE
VT	VIOLET
GY	GREY
WH	WHITE
PK	PINK

ALL SYMBOLS USED IS TAKEN FROM DS/EN 166

The following mounting wires must be used unless other instructions is noted.
Main circuit:

400VAC Phase = H07V2-K 1x2,5-4-6-10-16-25-35-50mm² Black
400VAC Neutral = H07V2-K 1x2,5-4-6-10-16-25-35-50mm² Light Blue
400VAC Ground = H07V2-K 1x2,5-4-6-10-16-25-35-50mm² Yellow/Green

230VAC Phase = H07V2-K 1x1,5mm² Black
230VAC Neutral = H07V2-K 1x1,5mm² Light Blue
230VAC Ground = H07V2-K 1x1,5mm² Yellow/Green

24VDC Phase = H07V2-K 1x0,75mm² Dark Blue
24VDC Neutral = H07V2-K 1x0,75mm² White
24VDC Ground = H07V2-K 1x0,75mm² Yellow/Green

All wire ends must be fitted with pins or cable shoes before mounting.

Marking of components, terminals, wires, cables.
Are according to standard DS / EN 60204-1 and electrical diagram

DECLARATION OF INCORPORATION

Directive 2006/42/EF, Annex II, B

Manufacturer

Firm: VS AUTOMATIC A/S
Address: Ormhøjgårdvej 15
DK-8700 Horsens
Phone: +45 75 64 18 99
Fax: +45 75 64 18 09
Email: info@vs-automatic.dk

Herewith declares that

Component: Controlpanel
Type: Throughpart drum 16 - 2016_01
Year of manufator: 2016

is intended to be incorporated into machinery or to be assembled with other machinery to constitute machinery covered by Directive 2006/42/EC

does therefor not in every respect comply with the provisions of this directive
does comply with the provisions of the following other EC directives

EC directives

Machine directive 2006/42/EC

EC low-voltage directives 2014/35/EU

EC EMC directive 2014/30/EU

Harmonized standards

EN60204-1 Safety of Machinery Electrical Equipment of Machines

EN60439-1 Low-voltage switchgear and controlgear assemblies part 1: Type-tested and partially type-tested assemblies

And furthermore declares that it is not allowed to put the machinery into service until the machinery into which it is to be incorporated or of which it si to be a component has been found and declared to be in conformity with the provisions of Directive 2006/42/EU and with national implementation legislation i.e. as a whole, including the machinery referred to in this declaration

Machine: Throughput drum 16 - 2016_01
Machine No.: 190071
Type: Year of manufactor: 2016
Manufacturer: Hedensted Gruppen A/S

Identification of signature:

Firm: VS AUTOMATIC A/S
Address: Ormhøjgårdvej 15
DK-8700 Horsens

Date: 30-05-2017

Signature



Torben Steffensen

VS AUTOMATIC

Tlf. 75 64 18 99 - vs-automatic.dk

En del af TS-GRUPPEN - Danmarks stærkeste El & Energi Installatører

Type: Hedensted Gruppen A/S

Project: Throughpart drum 16 - 2016_01

Printed: 30-05-2017

07:52:39

Changed: 29-05-2017 08:13:36

File: Throughpart drum 16 - 2016_01

Case no.: Throughpar

Page: E

of 11

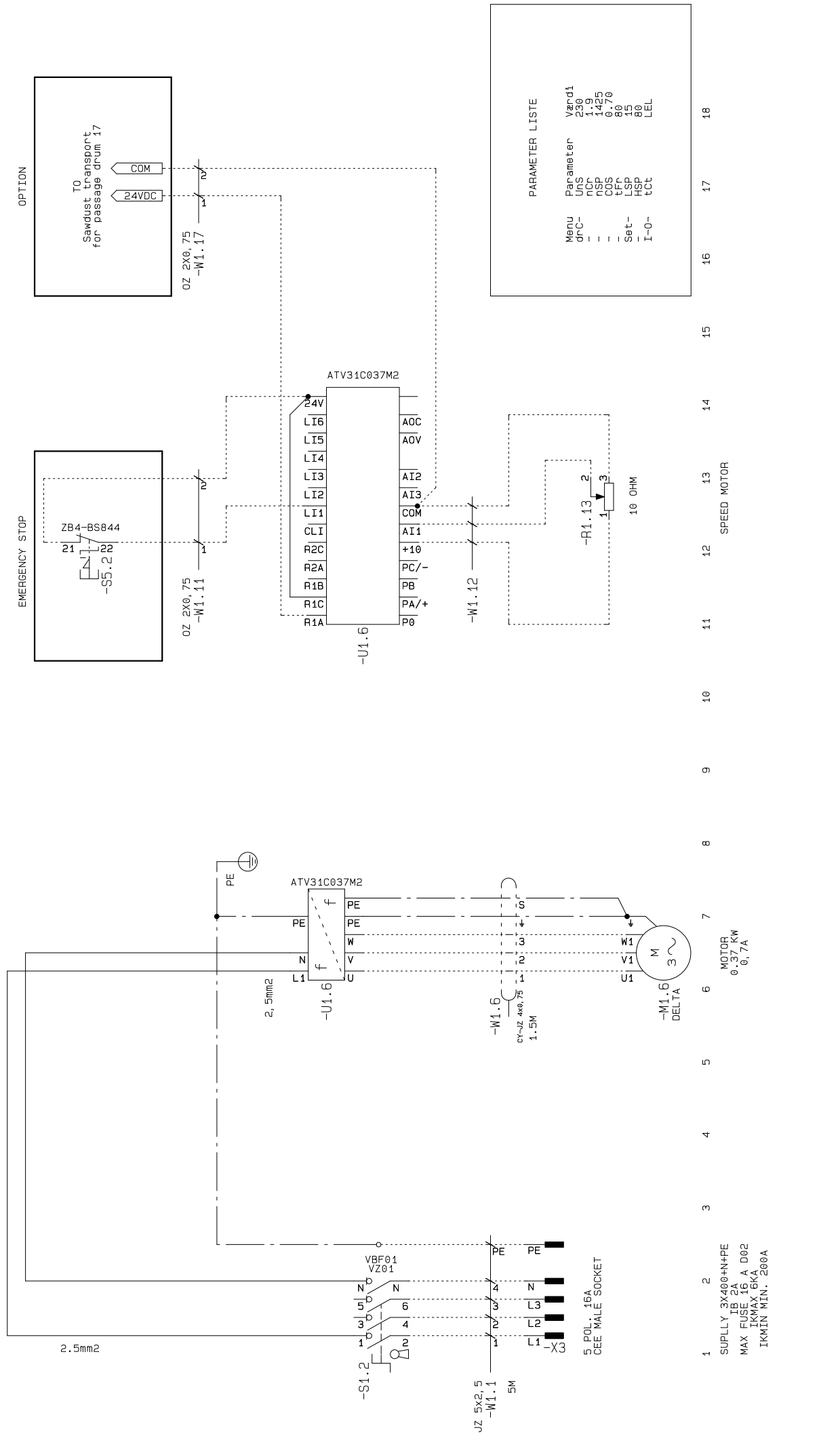

EMERGENCY STOP

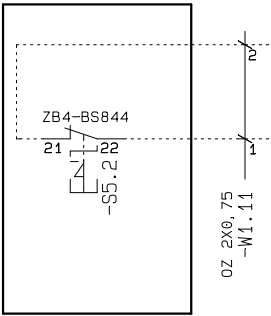

OPTION

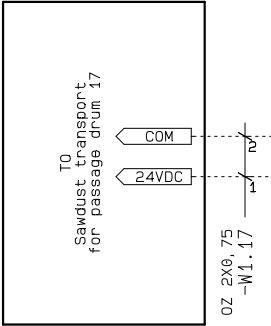

PARAMETER LISTE

Menu	Parameter	Var.d1
dr-C-	Uns	230
-	nCr	1.9
-	OSB	1425
-	OSL	80/70
Set-	LSP	15
I-0-	HSP	80
	tCt	LEL

1 SUPPLY 3X400+N+PE
 2 IB 2A
 3 MAX FUSE 16 A D02
 4 IKMAX 6KA
 5 IKMIN MIN. 200A

6 MOTOR
 0.37 KW
 0.7A

7 SPEED MOTOR
 10 OHM

16 17 18

VS AUTOMATIC
 Tlf. 75 64 18 99 - vs-automatic.dk
 En del af TS-GRUPPEN - Danmarks stærkeste EI & Energi installerator

Customer: Hedensted Gruppen A/S
 Project: Throughpart drum 16 - 2016_01
 Page title: CONVERTER MOTOR

Designer: TBT
 Last prt: 30-05-2017
 Last changed: 30-05-2017

Case no: Throughpart drum 16
 Page ref.:
 Page: 1 of 11

