

HG

SUPER SKUB HYDRA



SPARE PARTS LIST Year 2016 -

Made 08-02-2016

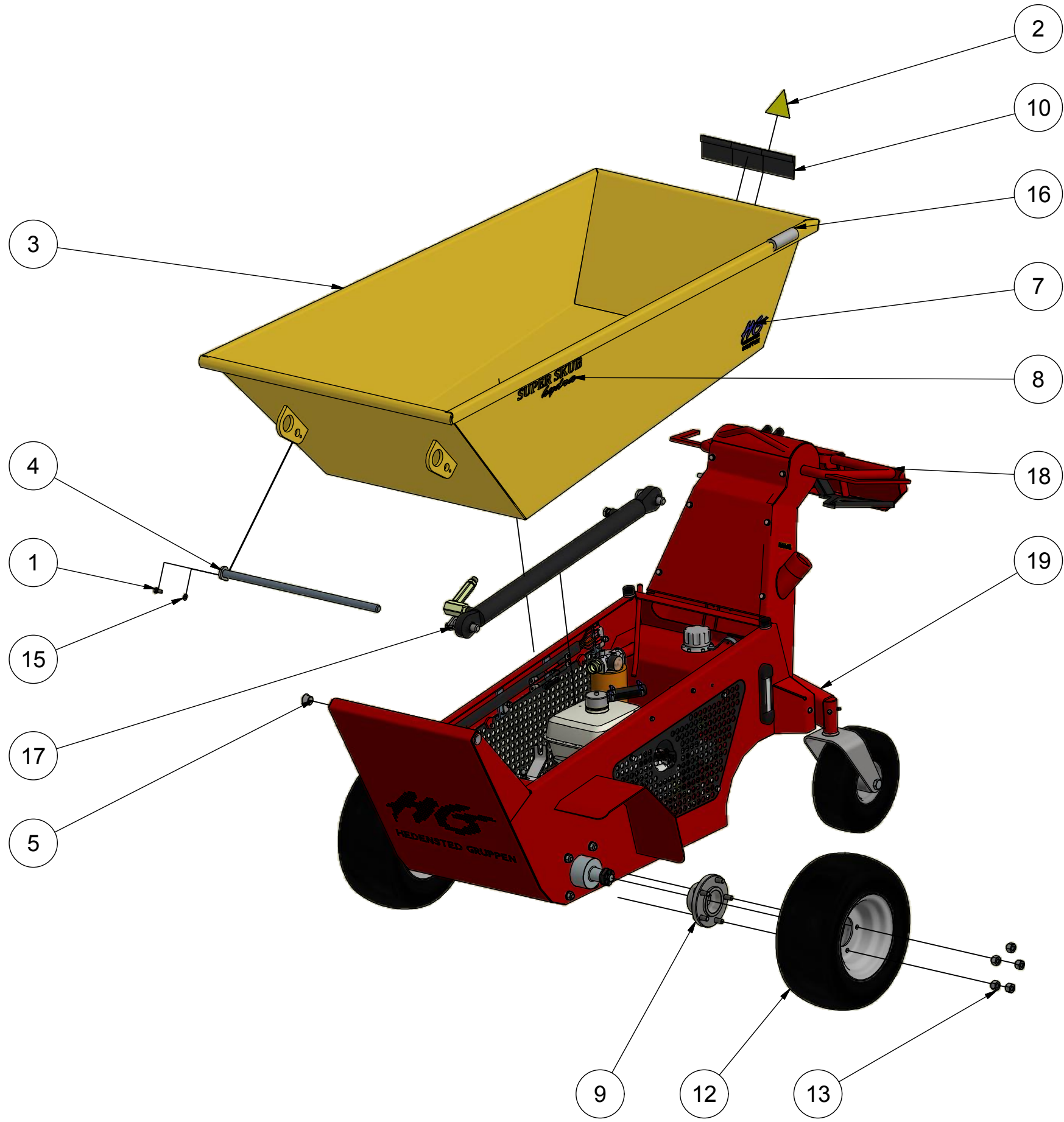

PARTS LIST			
ITEM	QTY	PART NUMBER	DESCRIPTION
1	1	11408016	Hexagon bolt M8x16 FZB
2	1	31009	Warning sign. Crushing
3	1	423400	Container for SS hydra
4	1	423410	Tilting shaft for hydra
5	2	423428	Slide bushing Ø20xØ23x15
6	1	423438	Logo forward,rev,tilt.throttle,
7	2	423439	HG Logo - size 75 x110mm
8	2	423440	Logo SS Hydra
9	2	423471	Wheel hub for omrw
10	0,3 m	423478	Edge profile w/Lip 54mm
11	1	423506	ID plate Super skub / Hydra
12	2	474733	Wheel F. LP190-8/8 Hf400 silve
13	10	479910	Wheel nut M12x1,5 NV22 60° FZB
14	4	7003208	Blind rivet Ø3.2x8 (4-5,5)
15	1	82108000	Washer M8 FZB
16	4,5 m	853026	Thermo insulation, 33/8mm
17	1	M102406	Hydraulic cylinder assembly
18	1	M102502	Base assembly 2, S.S Hydra 2016
19	1	M12110	Wheel suspension assembly



Revision:	Approved	Date:	Revision Description
1	KL	08-02-2016	Made

Break all edges

<small>The documents strictly confidential and must not be accounted by copied or disclosed to any third person.</small> HEDENSTED GRUPPEN A/S		Scale: 1 : 15	Not specified tolerance according to: DS/ISO 2768-m	Sheet size: A3
	HEDENSTED GRUPPEN		Surface properties: No	Sheet: 1 / 1
Part No.: 280100	Material:			
Description 1: HG S.S Hydra 2016 electric start				
Description 2: Incl. Suspension				

Parts List

ITEM	QTY	PART NUMBER	DESCRIPTION
1	1	43364	Wheel hub
2	5	479920	Hub bolt M12-1,5x36

Use jig and hydraulic press to mount bolts

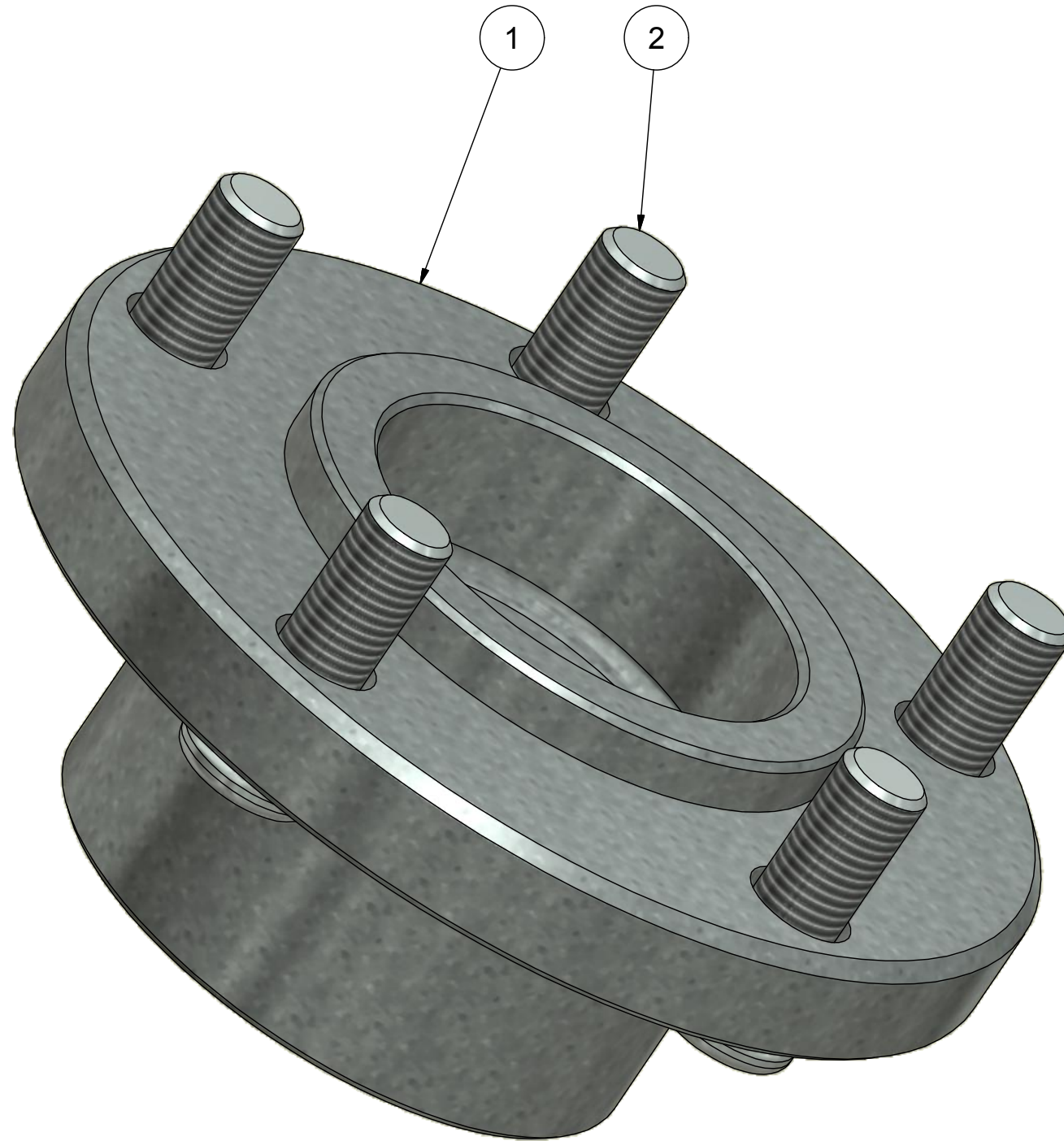

Break all edges

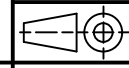
The document is strictly confidential and must not be disclosed to any third person. HEDENSTED GRUPPEN A/S	 HEDENSTED GRUPPEN	Scale: 2 : 1,5	Not specified tolerance according to: DS/ISO 2768-m	Sheet size: A3
			Surface properties:	Sheet: 1 / 1
	Part No.:	Material:		
	423471			
Description 1: Wheel hub for omrw				
Description 2: For OMRW 315				

Revision:	Approved	Date:	Revision Description
1	HG	28-09-2015	Revision changed to numeric

PARTS LIST

ITEM	QTY	PART NUMBER	DESCRIPTION
1	2	11408016	Hexagon bolt M8x16 FZB
2	2	423409	Lock pin for cylinder
3	1	423461	Hydraulic cylinder
4	1	423462	Hose leak valve
5	1	477100	Straight connector 3/8" x 3/8"
6	5	477163	Bopnded seal washer 3/8"
7	1	477222	Banjo bolt 3/8"
8	1	477225	Swiwel 90° GG 3/8"
9	2	82108000	Washer M8 FZB

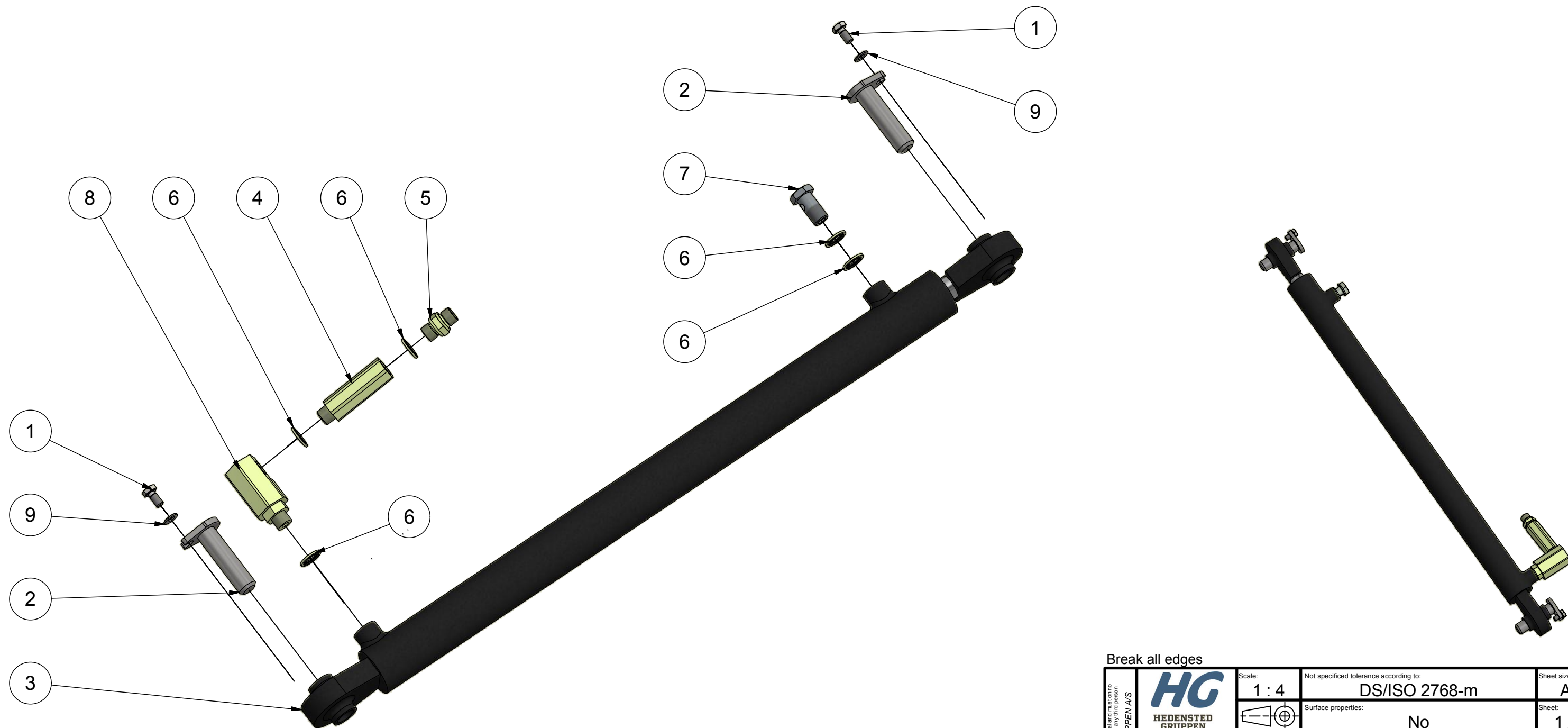

Break all edges

This document is strictly confidential and must not be used for any other purpose without the account of the copyright or disclosed to any third person. HEDENSTED GRUPPEN A/S	 HEDENSTED GRUPPEN	Scale: 1 : 4	Not specified tolerance according to: DS/ISO 2768-m	Sheet size: A3
	Part No.: M102406	Material:	Surface properties: No	Sheet: 1 / 1
	Description 1: Hydraulic cylinder assembly			
	Description 2:			

Revision:	Approved	Date:	Revision Description
1	SK	21-09-2016	Made

A (1 : 8)

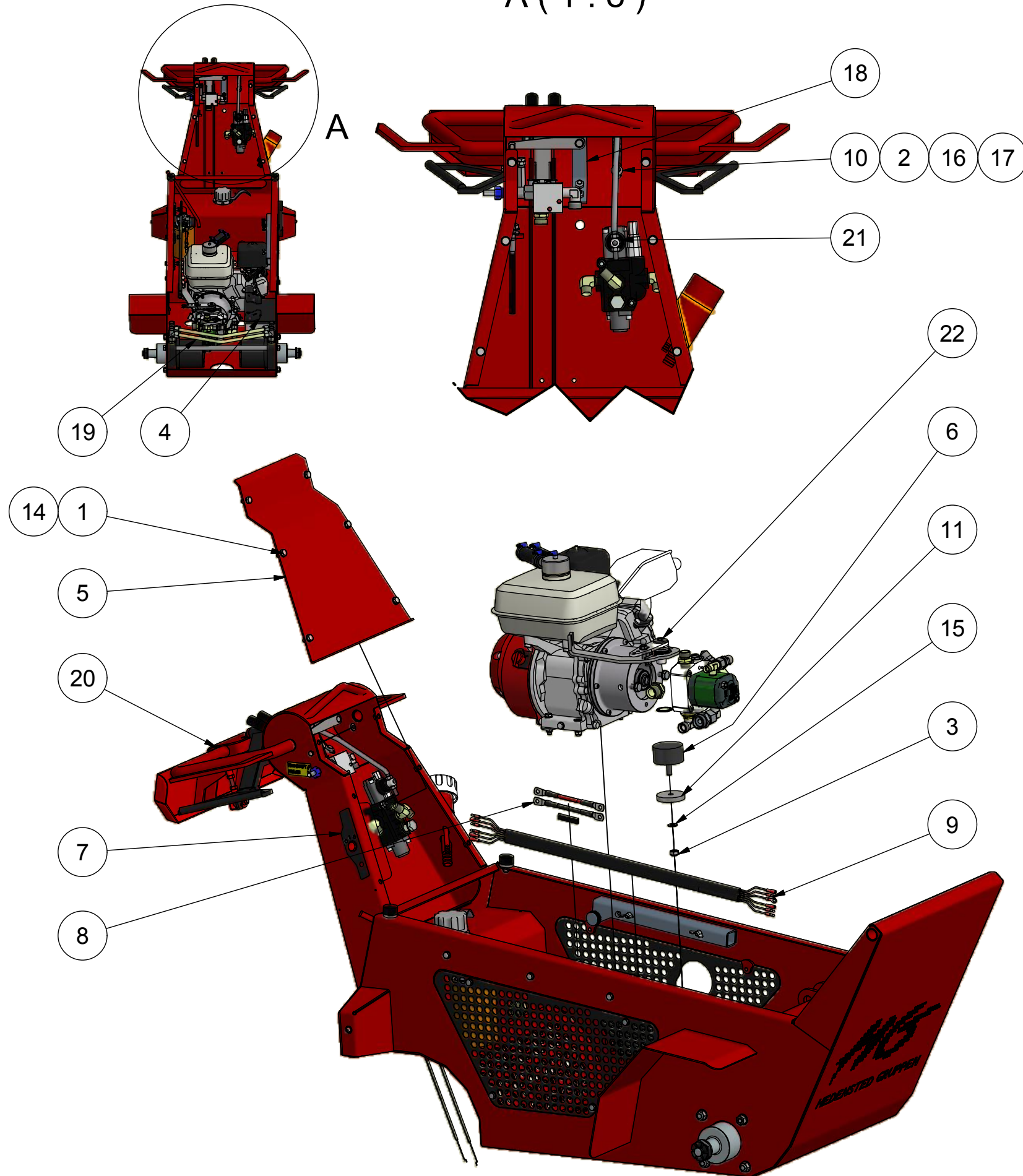

PARTS LIST

ITEM	QTY	PART NUMBER	DESCRIPTION
1	6	11408016	Hexagon bolt M8x16 FZB
2	1	11412016	Hexagon bolt M12x16 FZB
3	1	17910000	Self-locking nut M10 FZB
4	1	422676	Battery assembly
5	1	423411	Coverplate for frame
6	1	423421	Vibration absorber Ø65x35 - M10
7	1	423464	Sticker for key start
8	1	423468	Power supply for battery
9	1	423469	Power supply for engine
10	1	423482	Nut for stop screw
11	1	423542	Washer for vibration absorber
12	5,0 l	476505	Gasoline 95 unleaded
13	17,0 l	476721	Hydraulic oil Q8 handel 46
14	6	82108000	Washer M8 FZB
15	1	82110000	Washer M10 FZB
16	1	82112000	Washer M12 FZB
17	1	87512000	Spring washer M12 FZB
18	1	M102038	Assembly bearing for handle
19	1	M102490	Wheel motor assembly
20	1	M102503	Assembly frame 2
21	1	M102504	Valves assembly S.S 2016
22	1	M102505	Engine assembly 3 TMP

Break all edges

This document is strictly confidential and must not be used or disclosed to any third person. HEDENSTED GRUPPEN A/S	 HEDENSTED GRUPPEN	Scale: 1 : 10	Not specified tolerance according to: DS/ISO 2768-m	Sheet size: A3
	Part No.: M102502	Material:	Surface properties: No	Sheet: 1 / 1
	Description 1: S.S Hydra 2016, Base assembly 2			
	Description 2:			

Revision:	Approved	Date:	Revision Description
1	KL	08-02-2016	Made

Parts List

ITEM	QTY	PART NUMBER	DESCRIPTION
1	2	10212050	Hexagon cylinder head M12x50 FZB
2	1	421419	Negative terminal
3	2	423467	Brace for battery
4	1	423496	Cover for positive terminal
5	1	423497	Cover for gorund terminal
6	1	423529	Positive terminal
7	1	476010	Battery

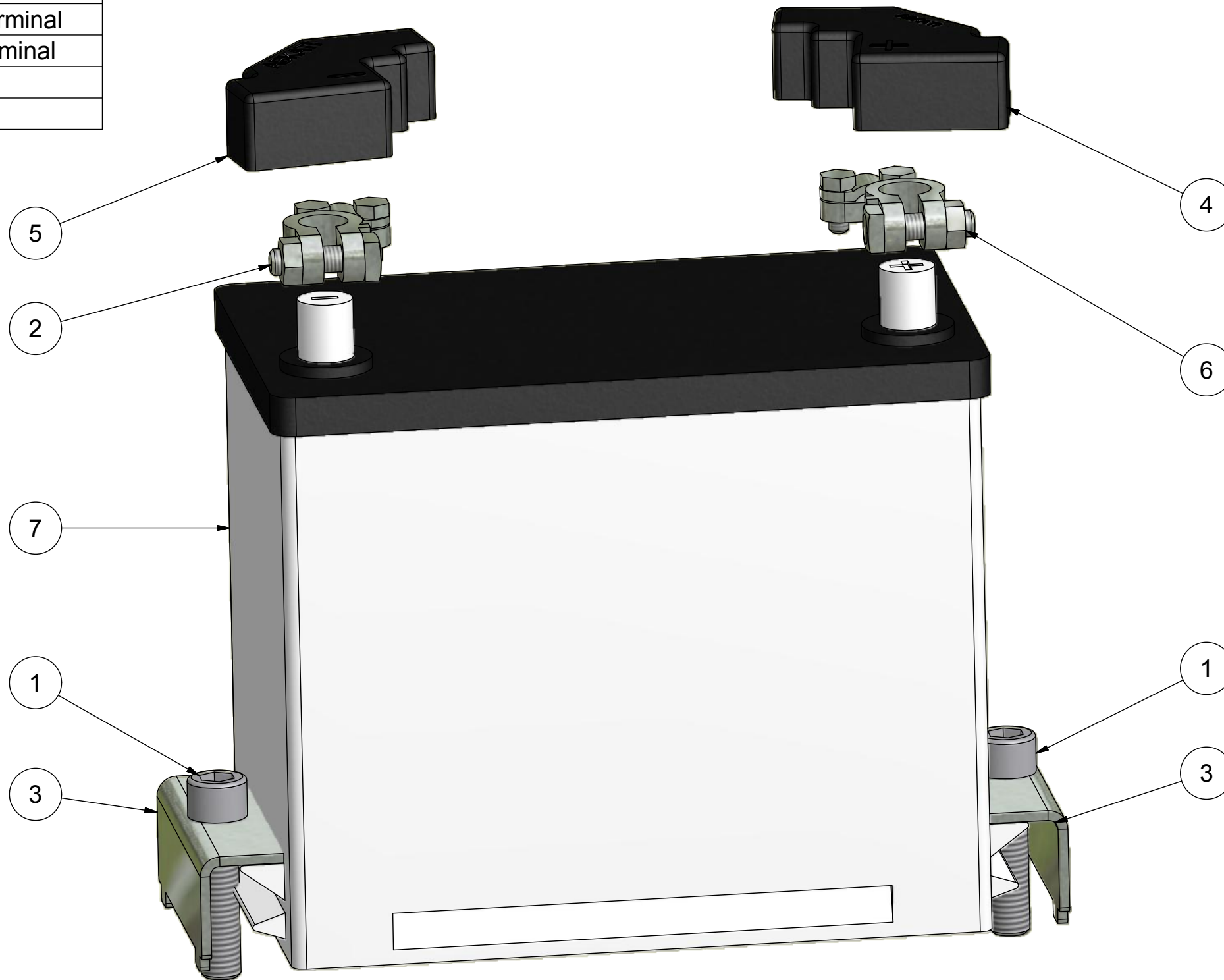

Break all edges

The document is strictly confidential and must not be account be copied or disclosed to any third person. HEDENSTED GRUPPEN A/S	 HEDENSTED GRUPPEN	Scale: 1 : 1,5	Not specified tolerance according to: DS/ISO 2768-m	Sheet size: A3
	Part No.: 422676	Material:	Surface properties:	Sheet: 1 / 1
Description 1: Battery assembly				
Description 2:				

Revision:	Approved	Date:	Revision Description
1	HG	28-09-2015	Revision changed to numeric

PARTS LIST			
ITEM	QTY	PART NUMBER	DESCRIPTION
2	1	423423	Slide bushing Ø12xØ14x7
5	1	423414	Bracket for butterfly handle
6	2	11408020	Hexagon bolt M8x20 FZB
7	2	82108000	Washer M8 FZB

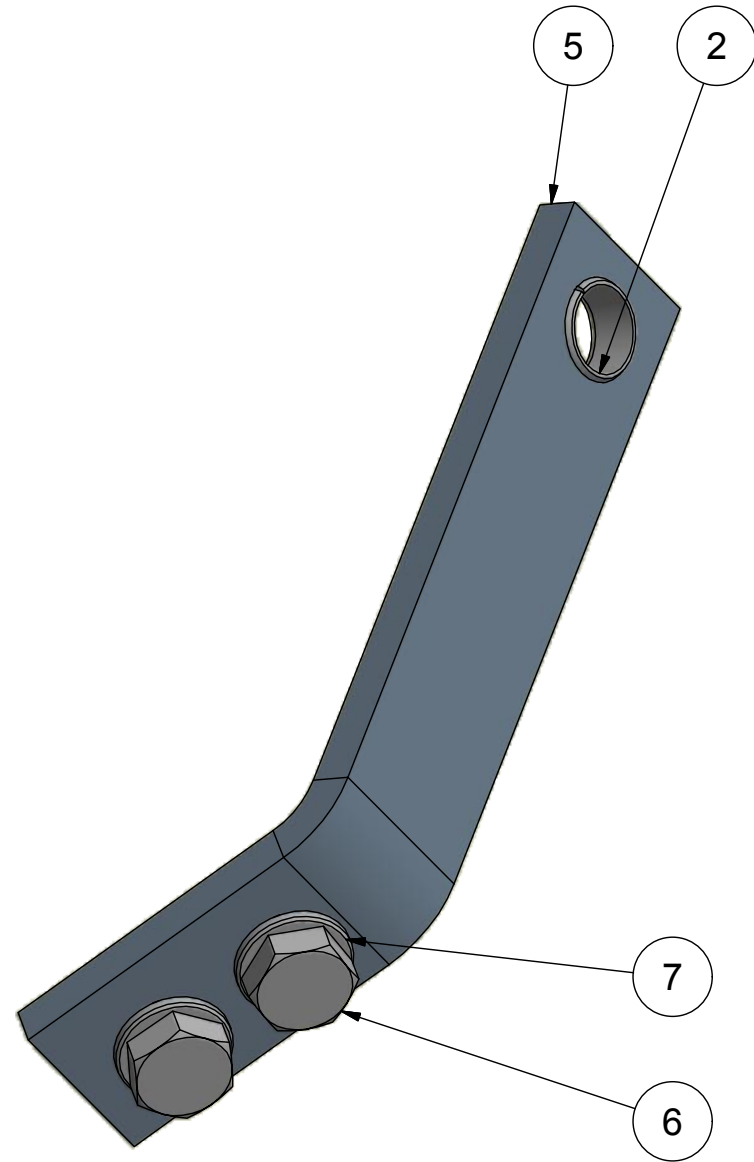

Break all edges

<small>This document is strictly confidential and must not be accounted for copied or disclosed to any third person.</small> HEDENSTED GRUPPEN A/S	 HEDENSTED GRUPPEN	Scale:	Not specified tolerance according to:	Sheet size:	
		1 : 1	DS/ISO 2768-m	A3	
	Part No.:	Material:		Surface properties:	Sheet:
				No	1 / 1
Part No.:		M102038			
Description 1:		Assembly bearing for handle			
Description 2:					

Revision:	Approved	Date:	Revision Description
1	SK	03-05-2016	Made

PARTS LIST

ITEM	QTY	PART NUMBER	DESCRIPTION
1	6	11412055	Hexagon bolt M12x55 FZB
2	7	17912000	Self-locking nut M12 FZB
3	1	423442	Pipe for wheel motor
4	2	423472	Hydraulic pipe for motor
5	2	423519	Wheel motor 347ccm Eaton delta
6	2	423545	Washer f/OMRW 45x20,5x4 FZB
18	4	424118	Cutting ring Ø15L
19	4	424122	Union Ø15L M22x1,5
7	4	477072	Tee Adjustable Ø15L x Ø15L x Ø15L (M/F/F)
8	8	82112000	Washer M12 FZB

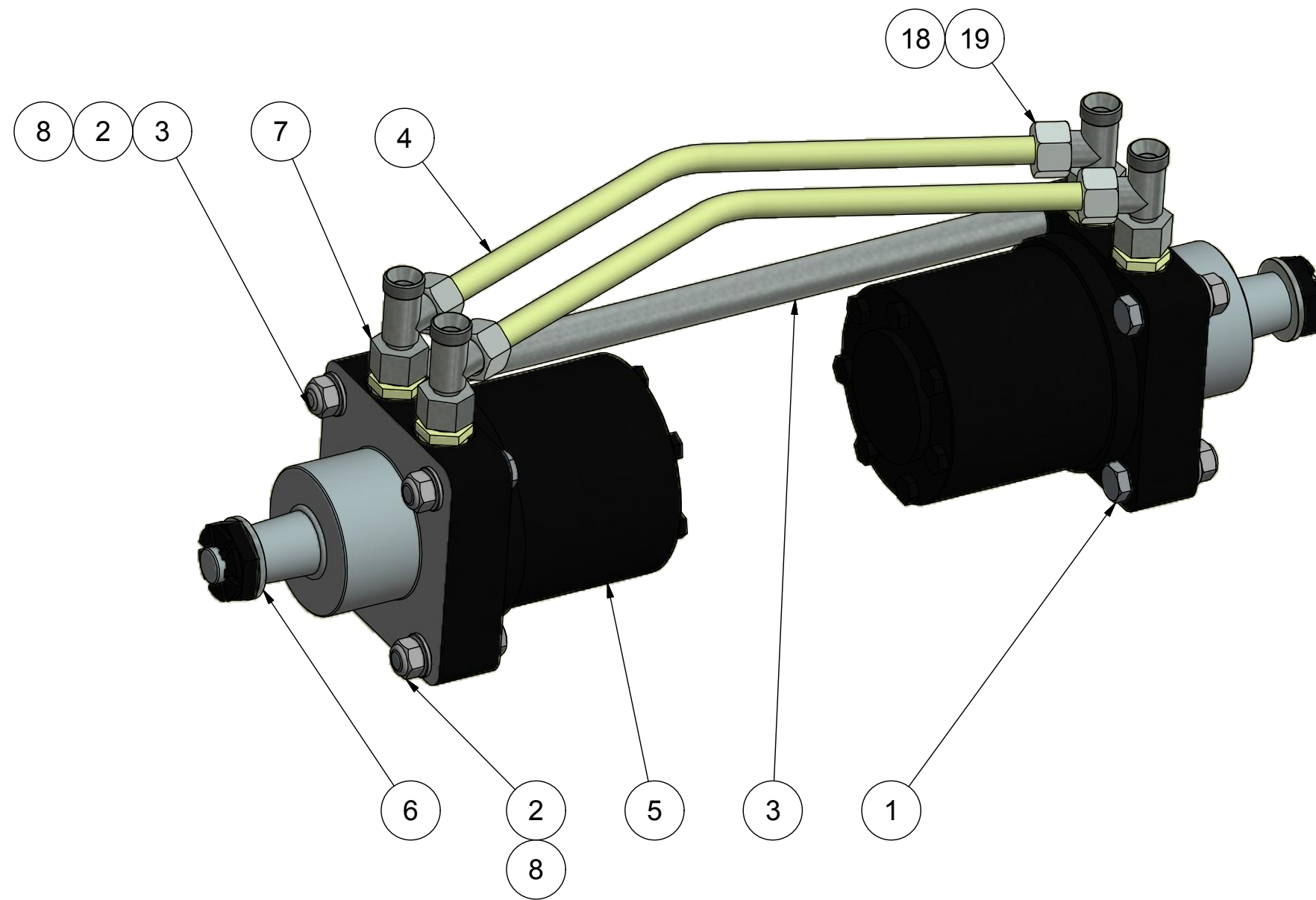

Break all edges

The document is strictly confidential and must not be disclosed to any third person. HEDENSTED GRUPPEN A/S	 HEDENSTED GRUPPEN	Scale: 1 : 3	Not specified tolerance according to: DS/ISO 2768-m	Sheet size: A3
	Part No.: M102490	Material:	Surface properties: No	Sheet: 1 / 1
Description 1:		Wheel motor assembly		
Description 2:		SS hydra		

Revision:	Approved	Date:	Revision Description
1	HG	09-01-2017	Made

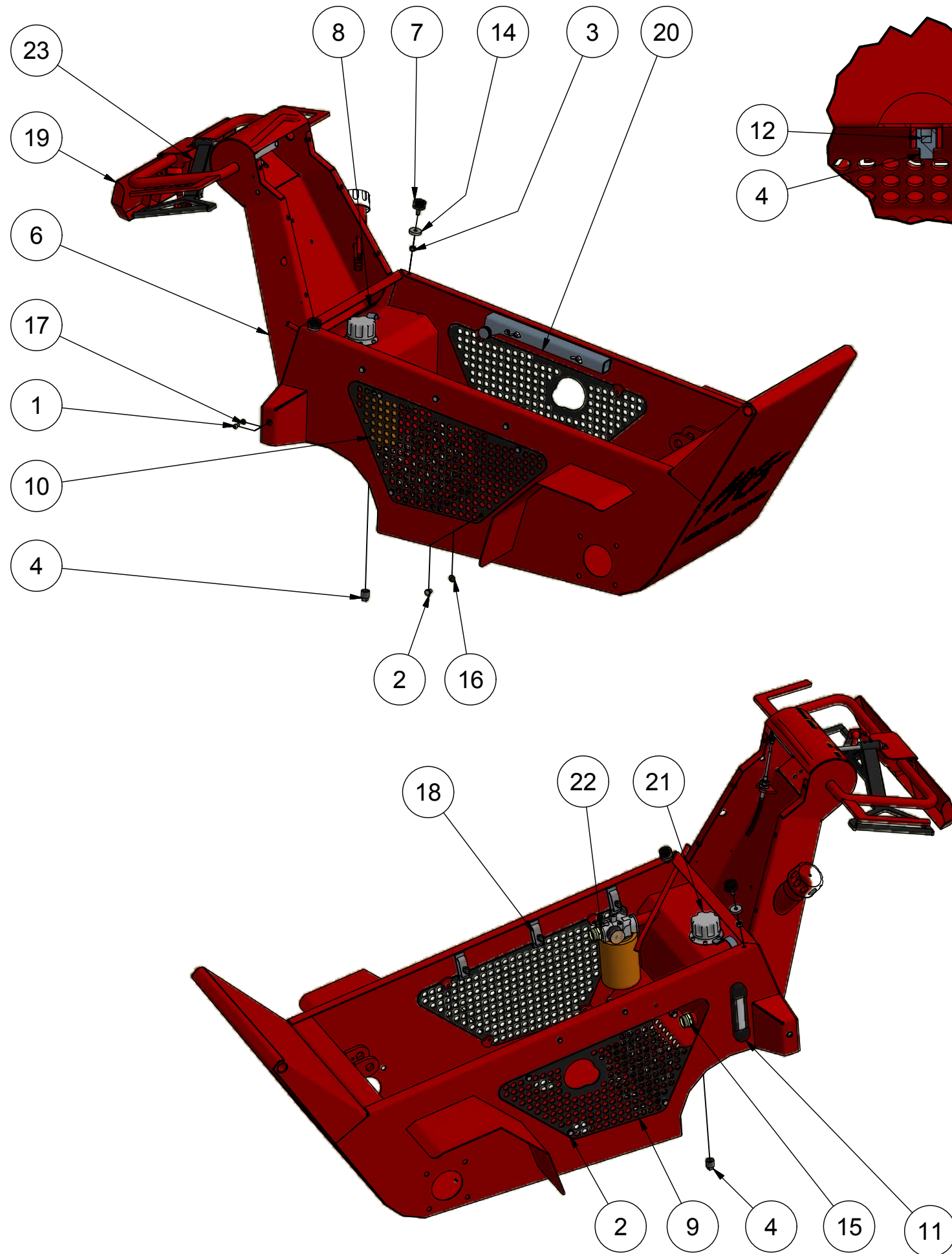

PARTS LIST

ITEM	QTY	PART NUMBER	DESCRIPTION
1	2	10206012	Hexagon cylinder head M6x12 FZB
2	8	11408012	Hexagon bolt M8x12 FZB
3	2	17908000	Self-locking nut M8 FZB
4	1	413038	Plug black 1/2", GF
5	2	423068	Grease nipple M6 straight
6	1	423402	Assembly frame
7	2	423422	Vibration absorber Ø30x15 - M8
8	0,9 m	423431	Edge protection strip
9	1	423434	Ventilation plate Left
10	1	423456	Ventilation plate right
11	1	423460	Oil level indicator
12	1	423475	Magnet Premax 302 ø12,5 x 10mm.
13	1	423477	Warning logo DK
14	2	423484	Spacer for rubber
15	1	477126	Straight connector w. gasket Ø22L x 3/4"
16	8	82108000	Washer M8 FZB
17	2	84506000	Spring washer M6 FZB
18	3	M102402	Hose clamp
19	1	M102403	Bumper assembly
20	1	M102405	Safety Clamp
21	1	M12105	Filler neck assembly
22	1	M12106	Oil filter assembly
23	1	M12107	Trottel grip assembly

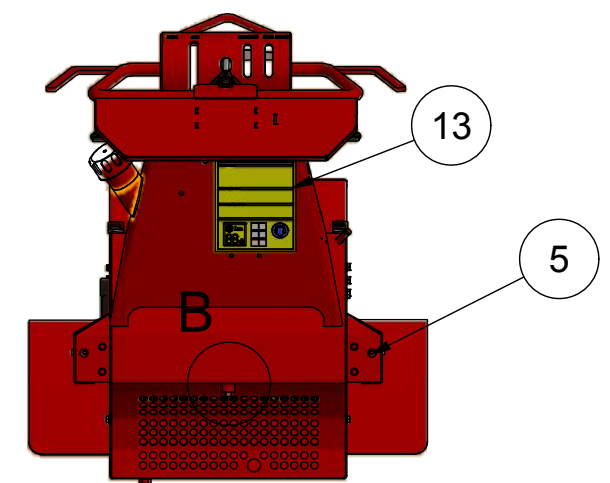

Break all edges

<small>This document is strictly confidential and must not be accounted for copied or disclosed to any third person.</small> HEDENSTED GRUPPEN A/S	HG	Scale:	Not specified tolerance according to:	Sheet size:
	<small>HEDENSTED GRUPPEN</small>	1 : 50	DS/ISO 2768-m	A3
	Part No.:		Surface properties:	Sheet:
	M102503	No	1 / 1	
Description 1:		Assembly frame 2		
Description 2:		Super skub Hydra 1026		

Revision:	Approved	Date:	Revision Description
1	KL	08-02-2016	Made

PARTS LIST

ITEM	QTY	PART NUMBER	DESCRIPTION
1	1	423418	Hydraulic hose clamp
2	1	423513	Clamp for hyd tube
3	1	11408055	Hexagon bolt M8x55 FZB
4	1	17908000	Self-locking nut M8 FZB
5	2	82108000	Washer M8 FZB

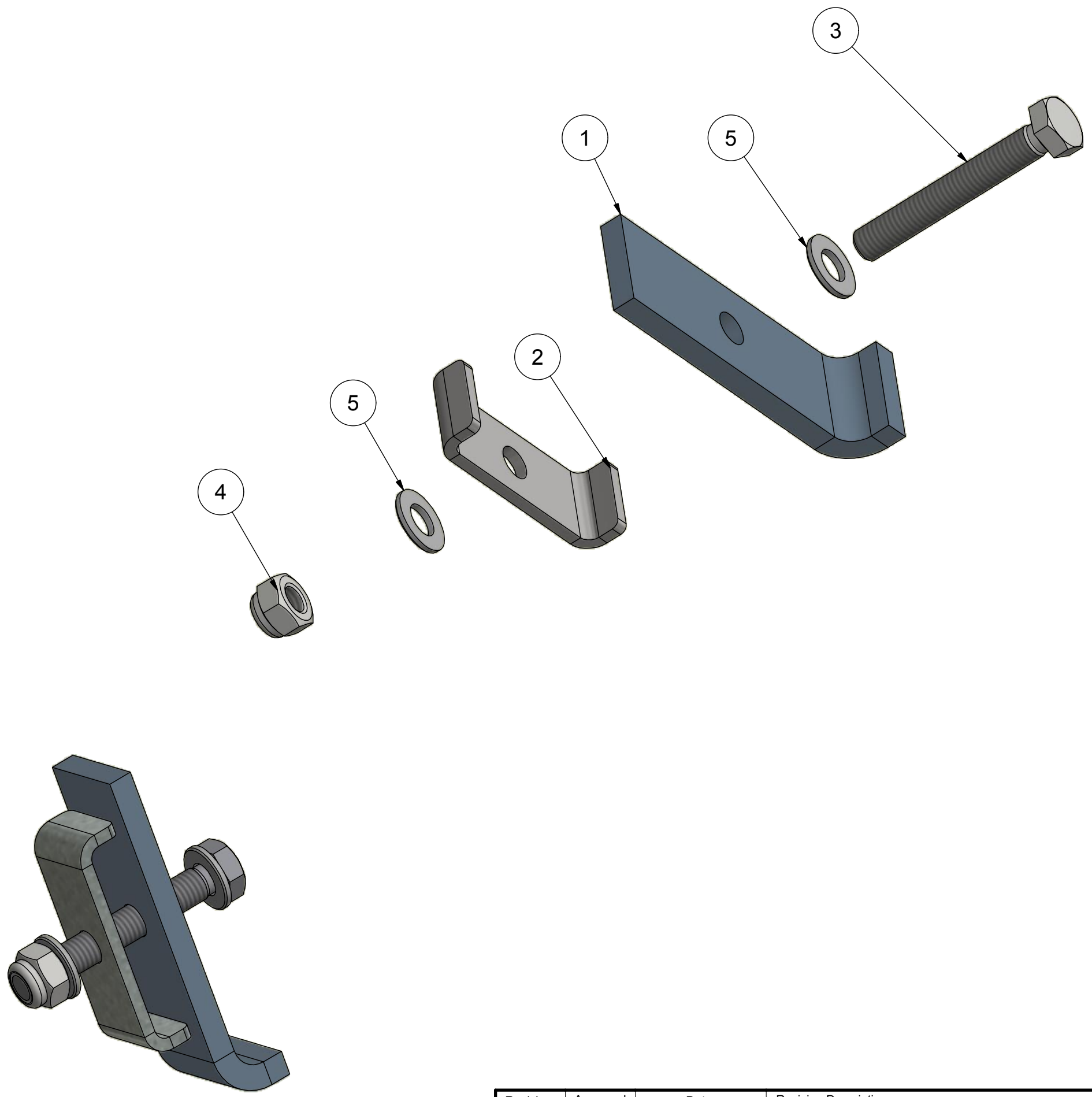

Break all edges

This document is strictly confidential and must not be disclosed to any third person. HEDENSTED GRUPPEN A/S		Scale: 1 : 1	Not specified tolerance according to: DS/ISO 2768-m	Sheet size: A3
		Surface properties: No	Sheet: 1 / 1	
	Part No.: M102402	Material:		
Description 1: Hose clamp				
Description 2:				

Revision:	Approved	Date:	Revision Description
1	SK	2016-09-21	Made

PARTS LIST

ITEM	QTY	PART NUMBER	DESCRIPTION
1	1	10508050	Stop screw M8x50-B
2	1	11406020	Hexagon bolt M6x20 FZB
3	2	1508000	Nut M8 FZB
4	1	17906000	Self-locking nut M6 FZB
5	2	17908000	Self-locking nut M8 FZB
6	2	415042	Ball angle joint AS13 M8
7	2	423423	Slide bushing Ø12xØ14x7
8	2	82106000	Washer M6 FZB
9	1	M100501	Lock rod assembly
10	1	M100503	Bumper assembly
11	2	M100507	Ball lock

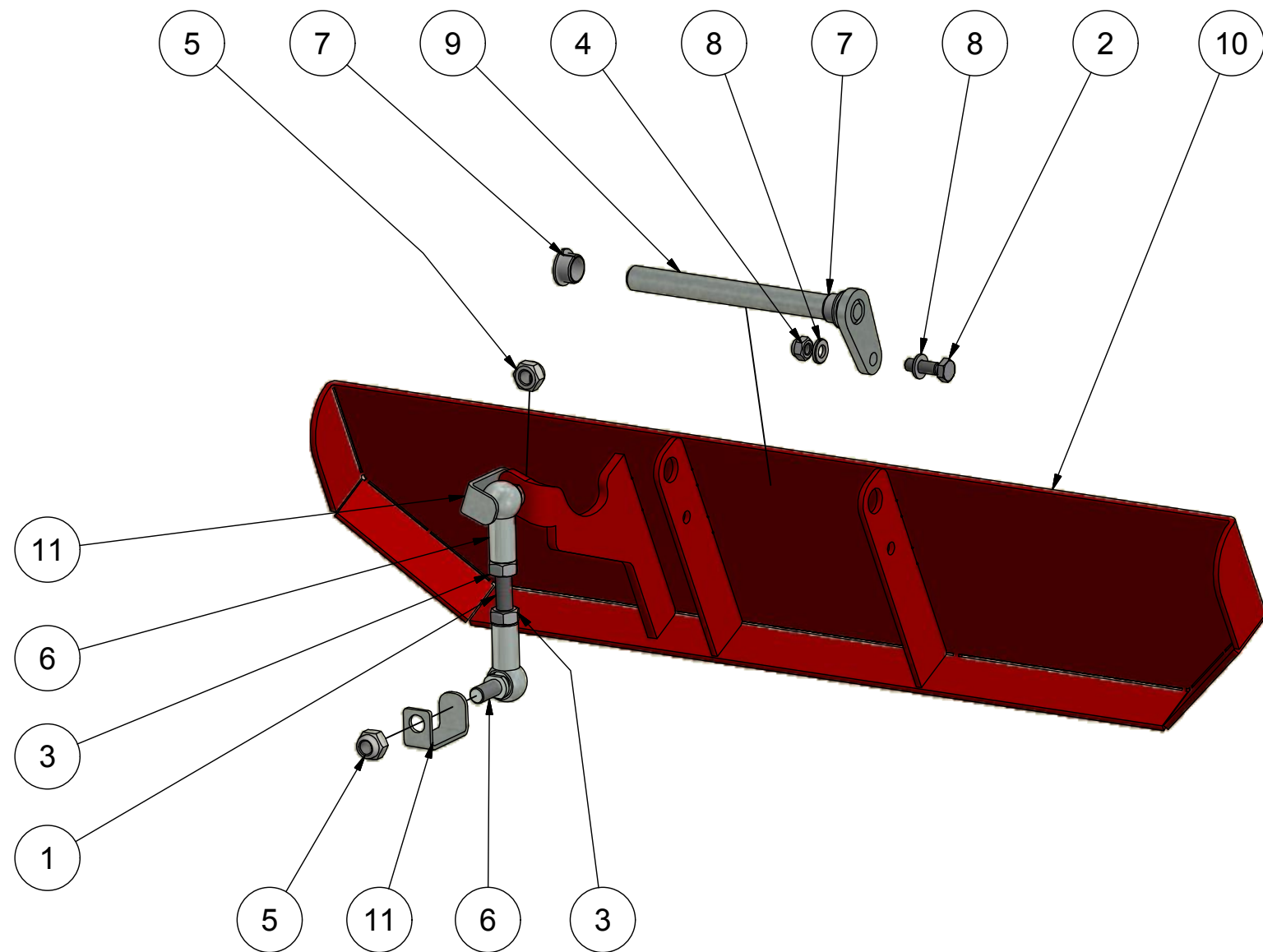

A (1:2)

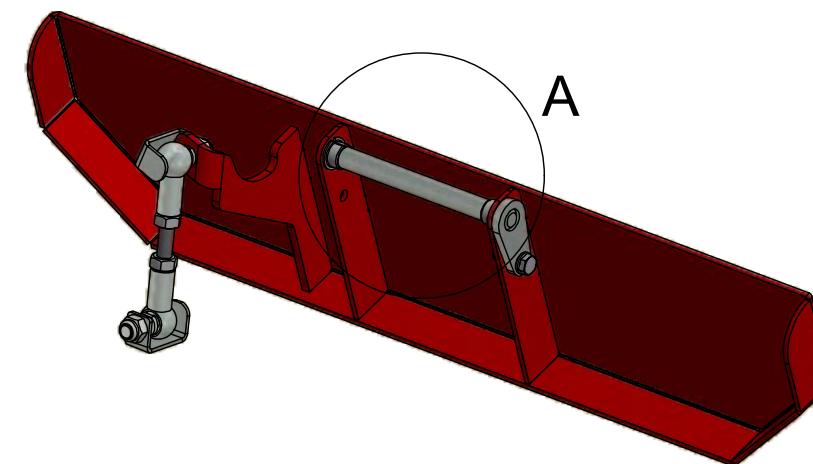
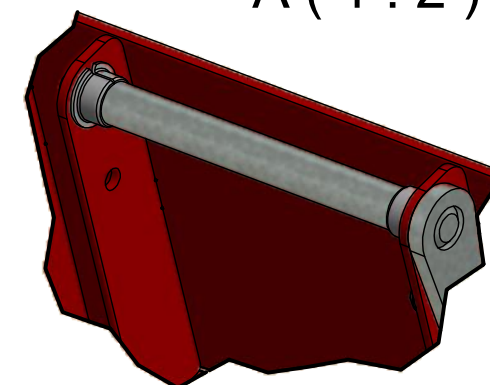

Break all edges

The document is strictly confidential and must not be accounted for copied or disclosed to any third person. HEDENSTED GRUPPEN A/S	 HEDENSTED GRUPPEN	Scale: 1 : 4	Not specified tolerance according to: DS/ISO 2768-m	Sheet size: A3
	Part No.: M102403	Material:	Surface properties: No	Sheet: 1 / 1
Description 1: Bumper assembly				
Description 2: Super skub Hydra				

Revision:	Approved	Date:	Revision Description
1	SK	21-09-2016	Made

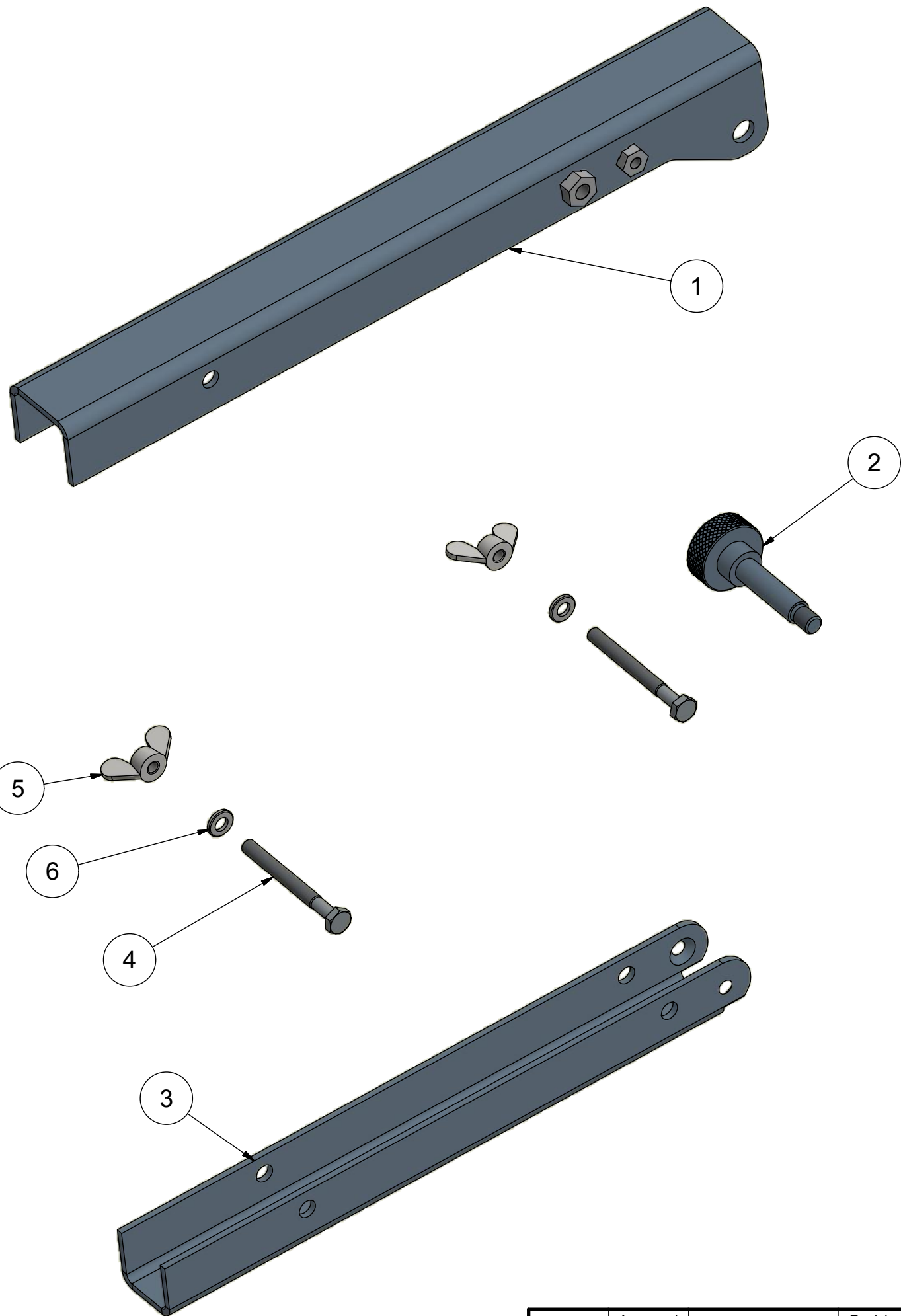

PARTS LIST			
ITEM	QTY	PART NUMBER	DESCRIPTION
1	1	43322	Safety clamp, outer part
2	1	43324	Fingerscrew with knurling
3	1	43329	Safety clamp, inner part
4	2	11406060	Hexagon bolt M6x60 FZB
5	2	19806000	Wing nut M6 FZB
6	2	82106000	Washer M6 FZB

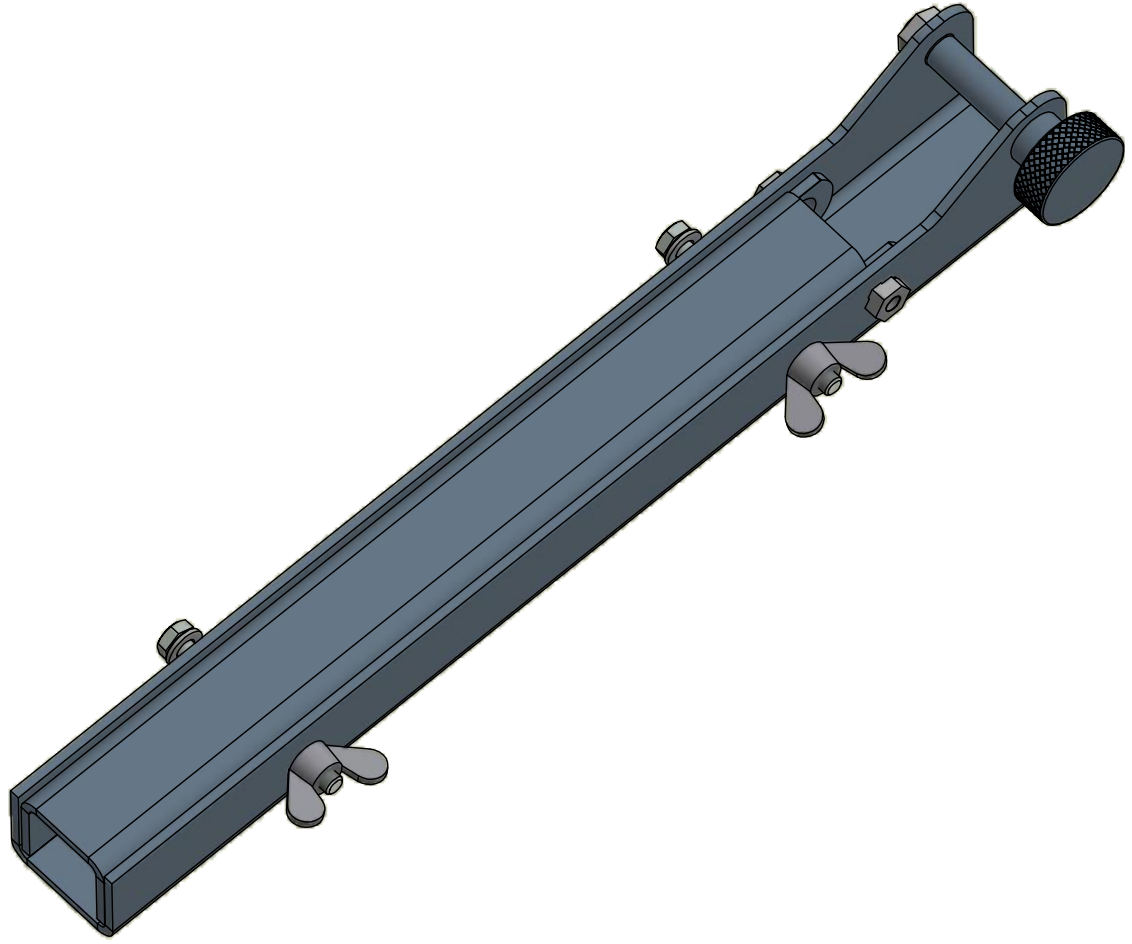

Break all edges

Revision:	Approved	Date:	Revision Description
1	SK	2016-09-21	Made

<small>This document is strictly confidential and must not be accounted for copied or disclosed to any third person.</small> HEDENSTED GRUPPEN A/S	 HEDENSTED GRUPPEN	Scale: 1 : 2	Not specified tolerance according to: DS/ISO 2768-m	Sheet size: A3
	Part No.: M102405	Material:	Surface properties: No	Sheet: 1 / 1
Description 1: Safety Clamp				
Description 2:				

PARTS LIST

ITEM	QTY	PART NUMBER	DESCRIPTION
1	1	423459	Fillerneck HB70 with filter
2	1	43349	Bracket for petrol hose
3	6	10205012	Hexagon cylinder head M5x12 FZB

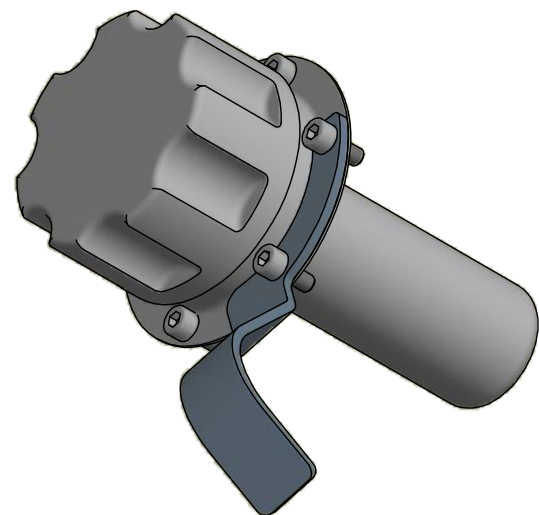
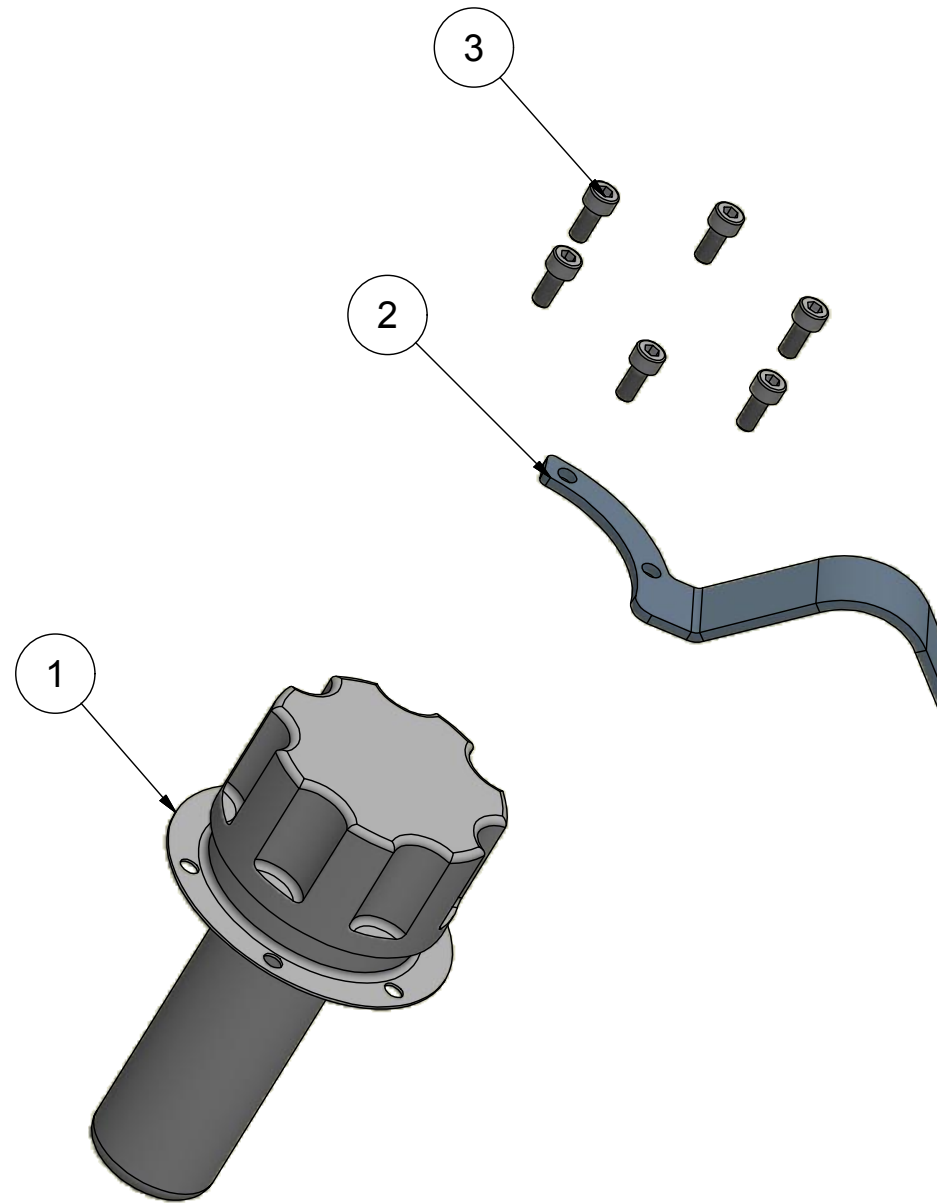

Break all edges

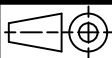
This document is strictly confidential and must not be accounted for copied or disclosed to any third person. HEDENSTED GRUPPEN A/S	 HEDENSTED GRUPPEN	Scale: 1 : 2	Not specified tolerance according to: DS/ISO 2768-m	Sheet size: A3
			Surface properties: No	Sheet: 1 / 1
	Part No.: M12105	Material:		
Description 1: Filler neck assembly				
Description 2:				

Revision:	Approved	Date:	Revision Description
1	SK	2016-09-22	Made

PARTS LIST			
ITEM	QTY	PART NUMBER	DESCRIPTION
1	1	423556	Filter head
2	1	423558	MP Oil filter
3	1	477126	Straight connector w. gasket Ø22L x 3/4"
4	1	423560	VS Vakuummeter Axial 0-76 CMHG

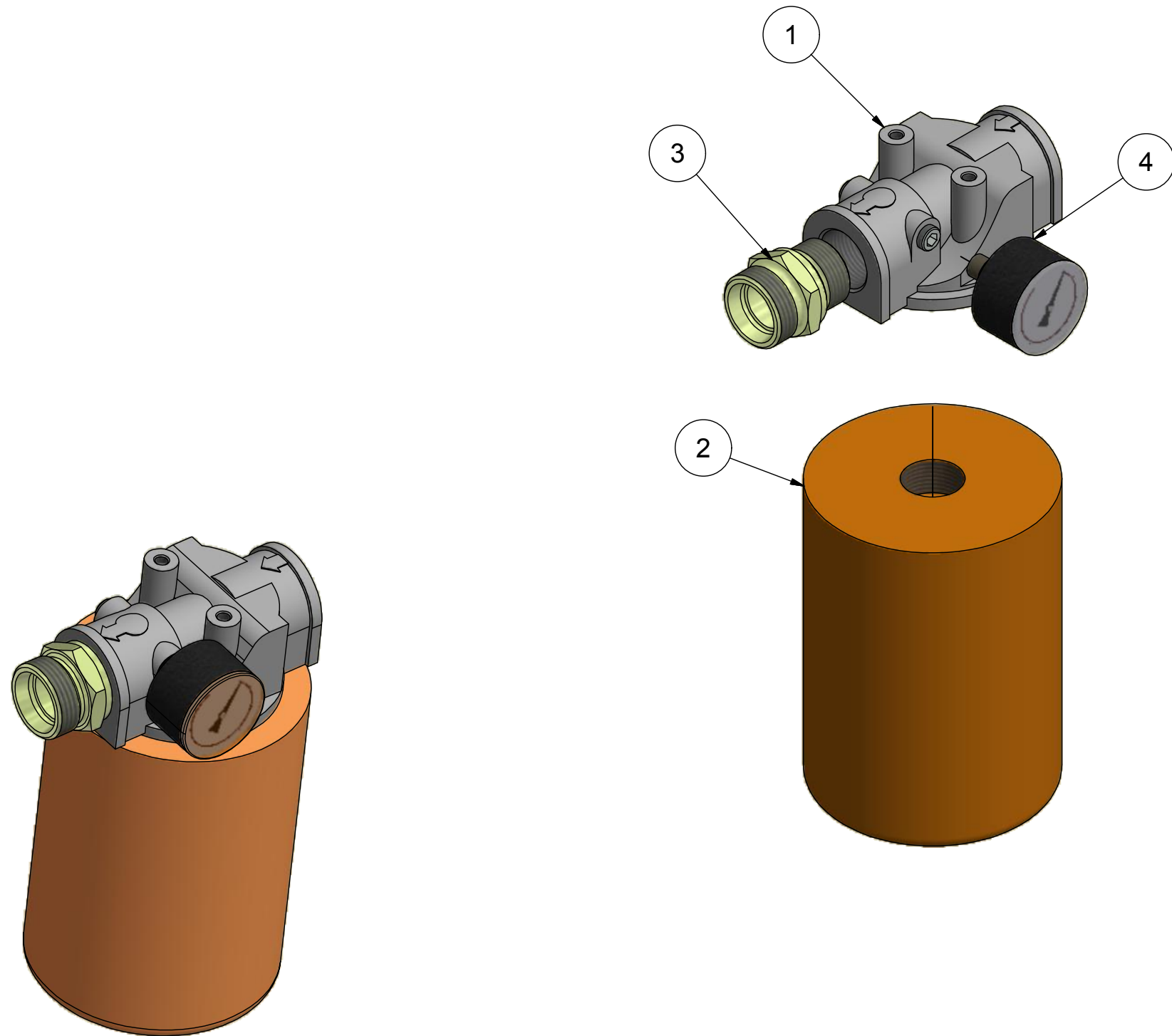

Break all edges

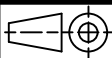
<small>This document is strictly confidential and must not be accounted for copied or disclosed to any third person.</small> HEDENSTED GRUPPEN A/S	 HEDENSTED GRUPPEN	Scale: 1 : 2	Not specified tolerance according to: DS/ISO 2768-m	Sheet size: A3
			Surface properties: No	Sheet: 1 / 1
	Part No.: M12106	Material:		
	Description 1: Oil filter assembly			
Description 2:				

Revision:	Approved	Date:	Revision Description
1	SK	22-09-2016	Made

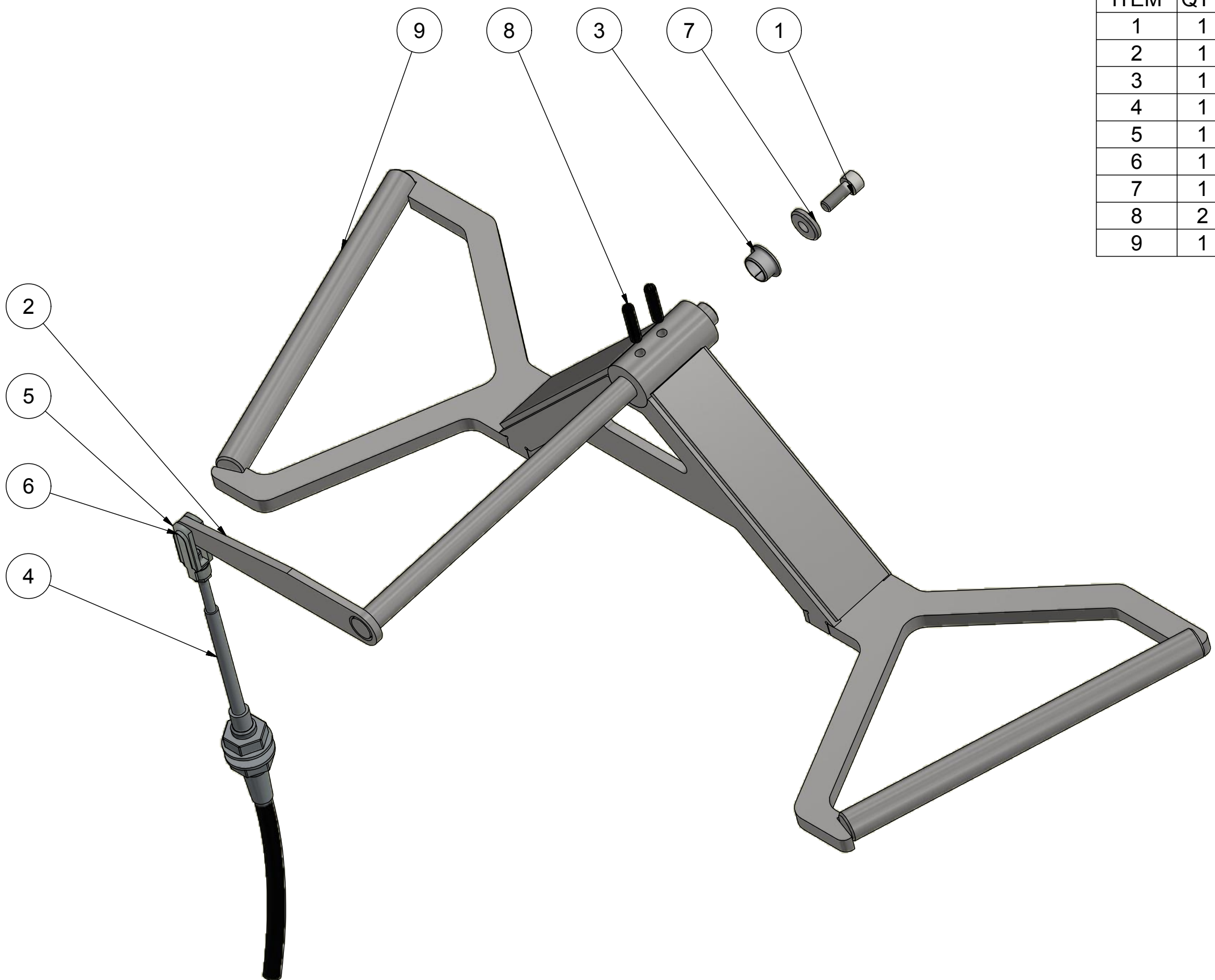

PARTS LIST			
ITEM	QTY	PART NUMBER	DESCRIPTION
1	1	10206016	Hexagon cylinder head M6x16 FZB
2	1	423408	Shaft for handle
3	1	423423	Slide bushing Ø12xØ14x7
4	1	423430	Steering cable, HG Super skub
5	1	423432	F-Bracket for cable G5x20
6	1	423443	Clips for F-joint
7	1	87606000	Washer Ø6,4x17x3 FZB
8	2	89505022	Pin slotted Ø5x22
9	1	M100499	Trottel grip

Break all edges

Revision:	Approved	Date:	Revision Description
1	SK	09-11-2016	Made

<small>The document is strictly confidential and must not be accounted for copied or disclosed to any third person.</small> HEDENSTED GRUPPEN A/S		Scale: 1 : 2	Not specified tolerance according to: DS/ISO 2768-m	Sheet size: A3
			Surface properties: No	Sheet: 1 / 1
Part No.: M12107		Material:		
Description 1: Trottel grip assembly				
Description 2:				

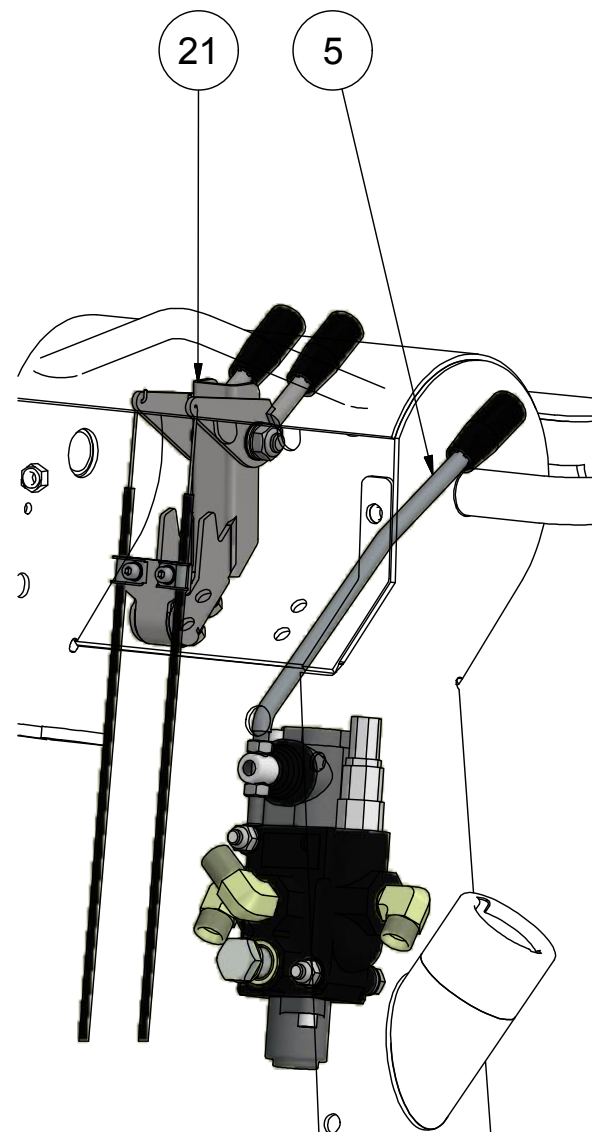
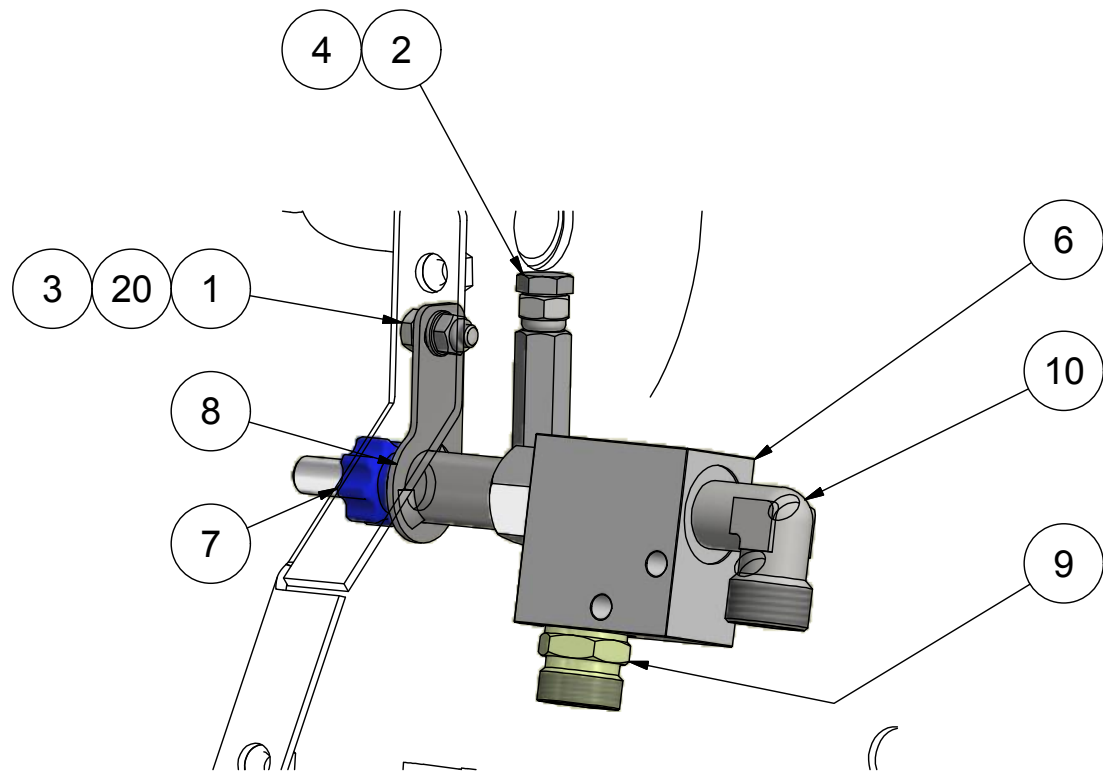
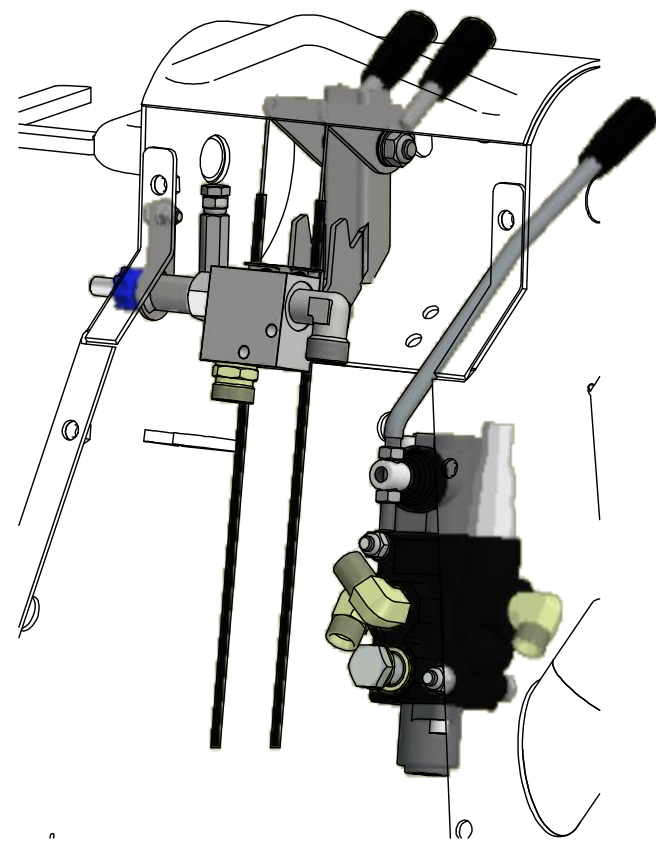

PARTS LIST

ITEM	QTY	PART NUMBER	DESCRIPTION
1	1	11406016	Hexagon bolt M6x16 FZB
2	1	11408035	Hexagon bolt M8x35 FZB
3	1	17906000	Self-locking nut M6 FZB
4	1	17908000	Self-locking nut M8 FZB
5	1	422663	Tilt valve assambly 2014
6	1	423570	Alu valveblock pipe mounted
7	1	423572	Valve, cartridge 12v DC 2 way with override
8	1	423584	Bracket for valve
9	1	477117	Straight connector w. gasket Ø15L x 3/8"
10	1	477146	Elbow 3/8"t x Ø15L
11	1	477246	Hyd. hose 1/2"x580mm No.56
12	1	477251	Hydr.hose 1/2x500mm. No.55
13	1	477252	Hydr.hose 3/8"x1620mm No.51
14	1	477254	Hydr.hose 3/8"x1450mm No.54
15	2	477255	Hydr.hose 1/2"x1700mm.
16	1	477259	Hydr.hose 3/4x870mm. No.59
17	1	477261	Hydr.hose 3/4x800mm.No.60
18	1	477263	Hydr.hose 3/8x1850mm. No.53
19	1	477266	Hydr.hose 3/8x2530mm.No.52
20	1	82106000	Washer M6 FZB
21	1	M102486	Throttle/choke assembly

Break all edges

This document is strictly confidential and must not be disclosed to any third person. HEDENSTED GRUPPEN A/S	HG	Scale: 1 : 4	Not specified tolerance according to: DS/ISO 2768-m	Sheet size: A3
	HEDENSTED GRUPPEN		Surface properties: No	Sheet: 1 / 1
	Part No.: M102504	Material:		
	Description 1: Valves assembly S.S 2016			
Description 2:				

Revision:	Approved	Date:	Revision Description
1	KL	08-02-2016	Made

PARTS LIST

ITEM	QTY	PART NUMBER	DESCRIPTION
1	2	11408065	Hexagon bolt M8x65 FZB
2	2	1508000	Nut M8 FZB
3	2	17908000	Self-locking nut M8 FZB
4	1	423424	Handle, Ø21 cylindrical knob Ø10
5	1	423522	Handle for tilt valve
6	1	423526	Hydraulic tilt valve
7	1	477105	Elbow 3/8"t x 3/8"t (M/M)
8	2	477139	Elbow 3/8"t x Ø12L
9	2	477163	Bopnded seal washer 3/8"
10	1	477222	Banjo bolt 3/8"
11	4	82108000	Washer M8 FZB

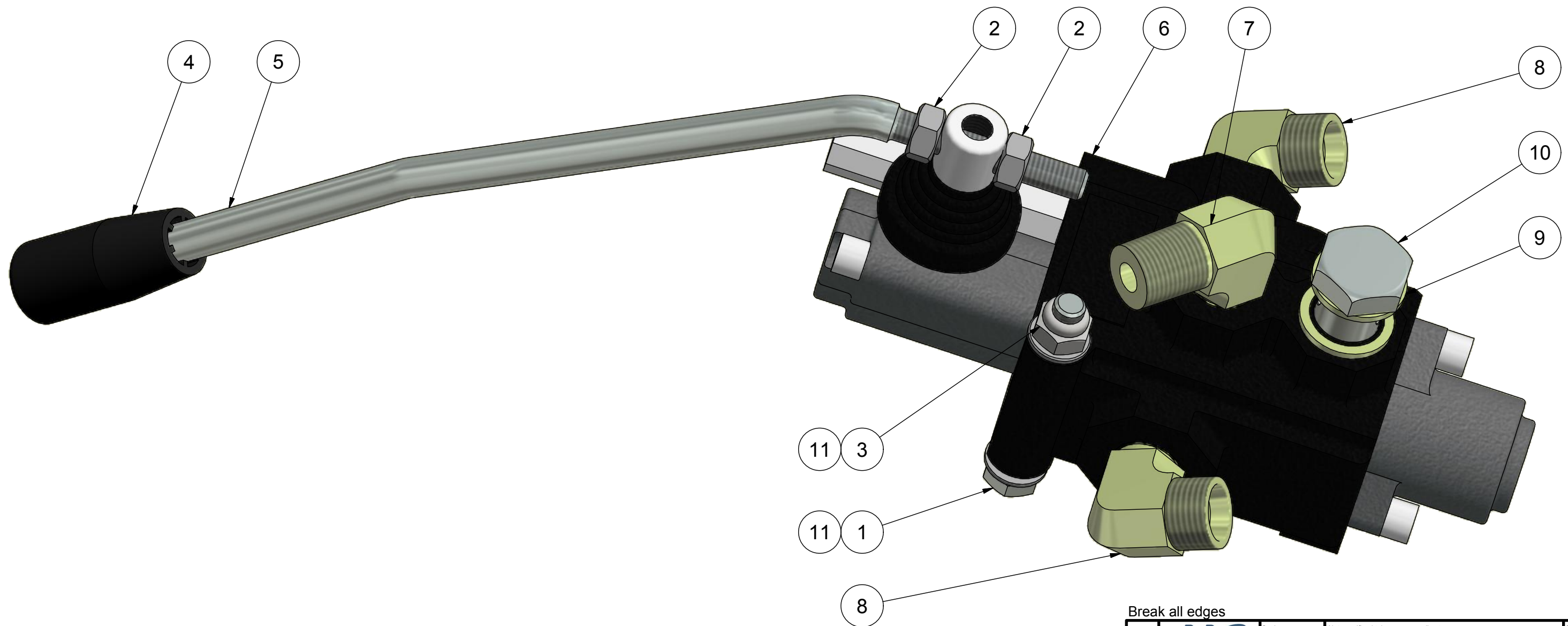

Break all edges

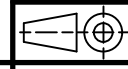
This document is strictly confidential and must not be disclosed to any third person. HEDENSTED GRUPPEN A/S		Scale: 1:1	Not specified tolerance according to: DS/ISO 2768-m	Sheet size: A3
	HEDENSTED GRUPPEN		Surface properties: No	Sheet: 1/2
	Part No.: 422663	Material:		
	Description 1: Tilt valve assambly 2014			
Description 2: Hydra combi + SS				

Revision:	Approved	Date:	Revision Description
1	HG	27-09-2015	Revision changed to numeric

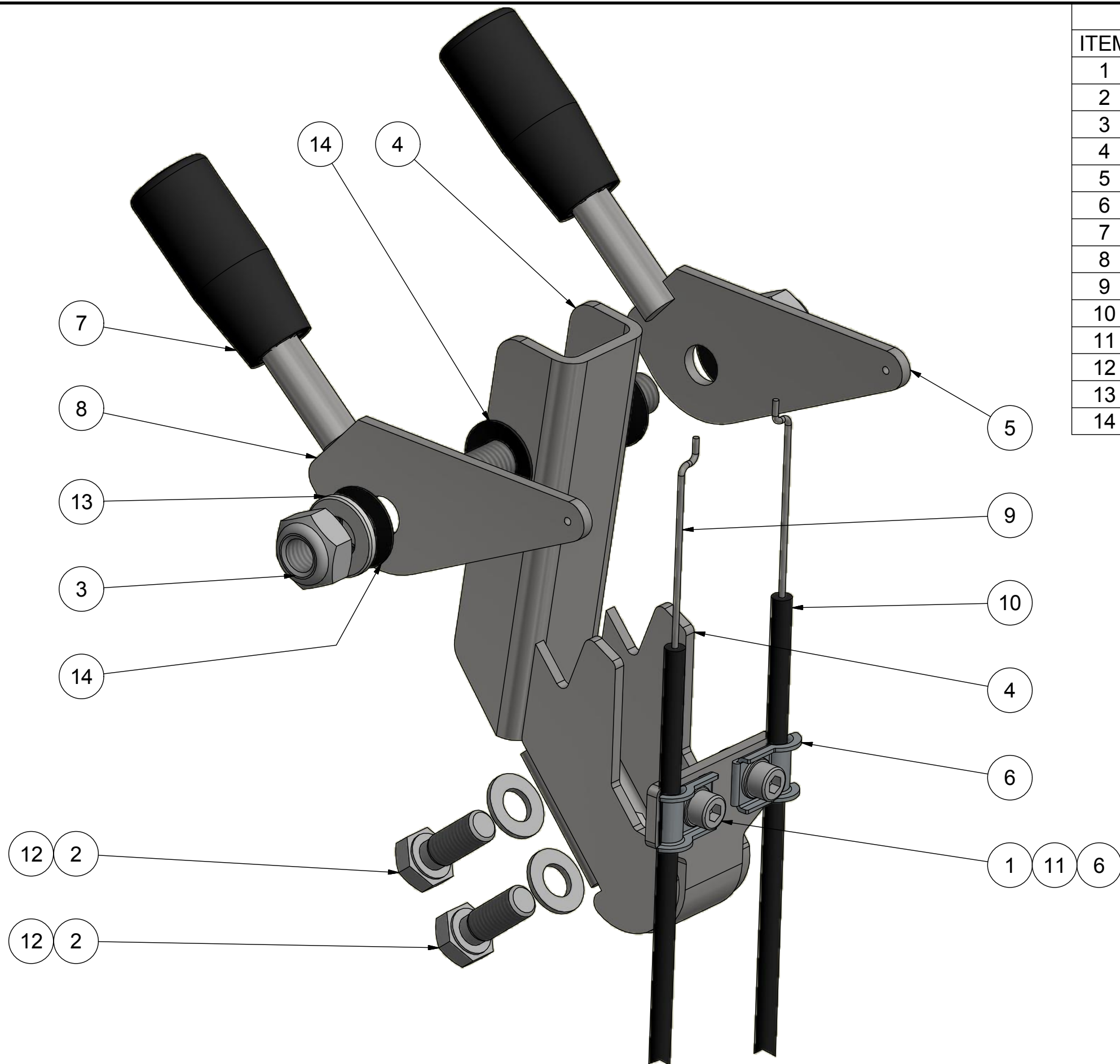

Parts List			
ITEM	QTY	PART NUMBER	DESCRIPTION
1	2	10205012	Hexagon cylinder head M5x12 FZB
2	2	11408020	Hexagon bolt M8x20 FZB
3	2	17910000	Self-locking nut M10 FZB
4	1	423412	Brace for throttle and choke
5	1	423413	Gas choke handle right
6	2	423419	Cable clamp
7	2	423424	Handle, Ø21 cylindrical knob Ø10
8	1	423426	Gas/choke handle left
9	1	423429	Gas cable S.S. Hydra.
10	1	423437	Choker cable S.S. Hydra.
11	2	82105900	Washer M5 FZB
12	2	82108000	Washer M8 FZB
13	2	82110000	Washer M10 FZB
14	4	89310080	Disc spring 20x10,5x0,8

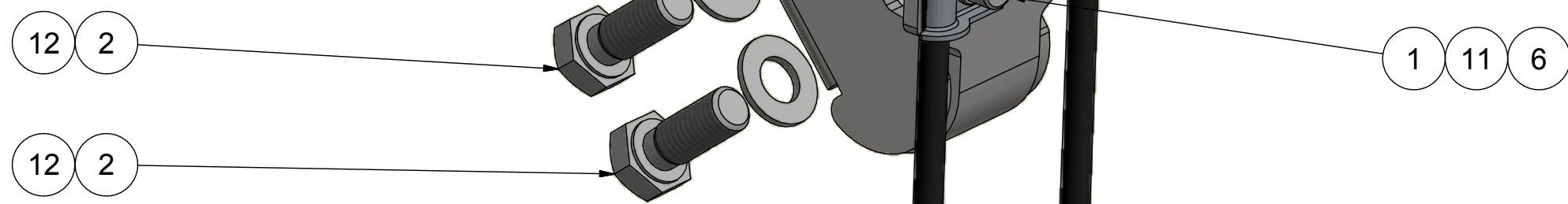

Break all edges

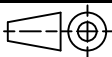
The documents strictly confidential and must not be accounted by copied or disclosed to any third person. HEDENSTED GRUPPEN A/S	 HEDENSTED GRUPPEN	Scale: 1:1 	Not specified tolerance according to: DS/ISO 2768-m Surface properties:	Sheet size: A3 Sheet: 1 / 1
	Part No.: M102486		Material:	
	Description 1: Throttle/choke assembly			
	Description 2: SS hydra			

Revision:	Approved	Date:	Revision Description
1	HG	05-01-2017	Made

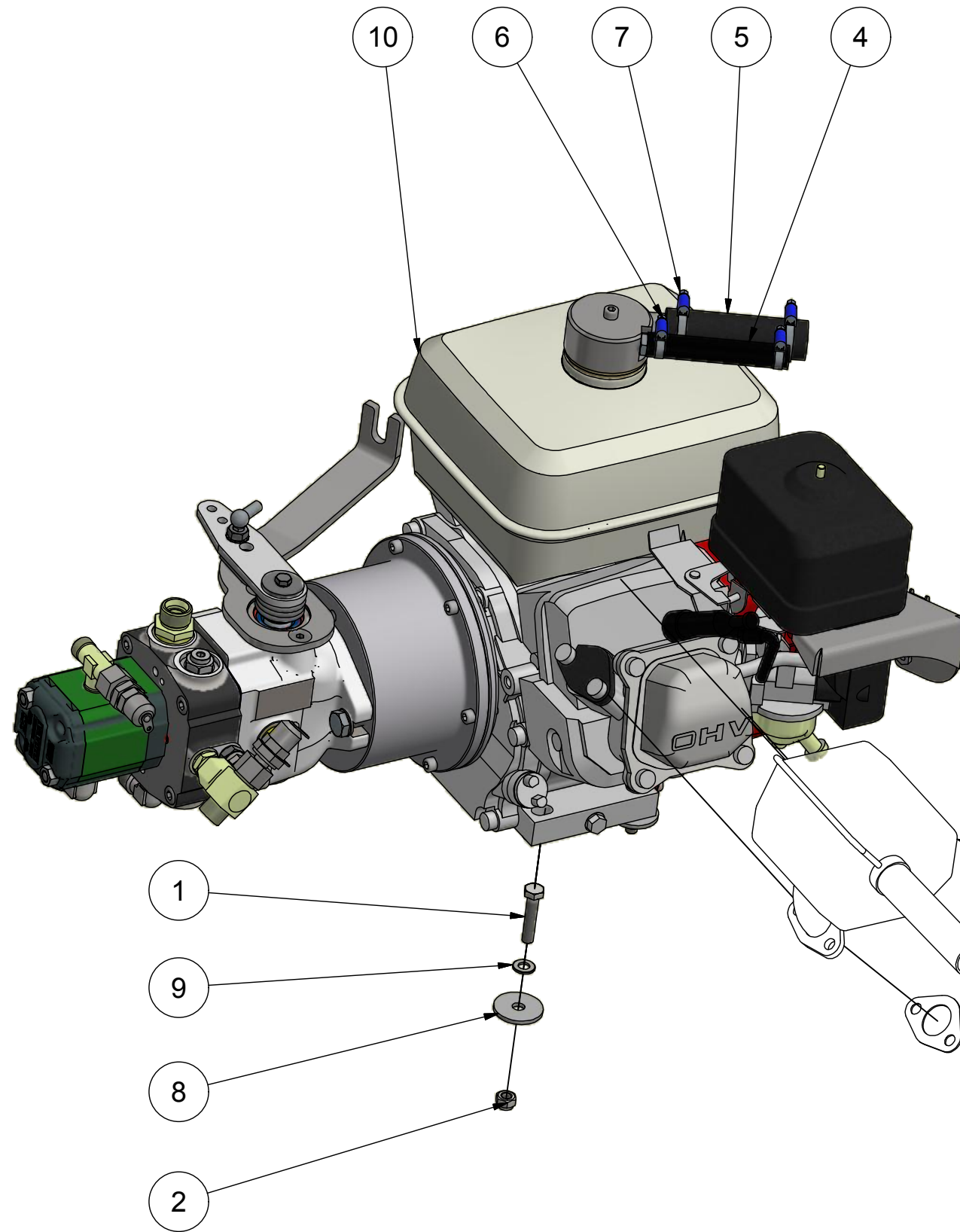

PARTS LIST			
ITEM	QTY	PART NUMBER	DESCRIPTION
1	4	11408040	Hexagon bolt M8x40 FZB
2	4	17908000	Self-locking nut M8 FZB
3	1	423420	Pipe for exhaust
4	0,6 m	423451	Fuel hose hydro eco 10x3,5
5	0,6 m	423452	Fuel hose 19x6,0
6	2	474006	Hose clamp 11-16
7	2	474008	Hose clamp 22-30
8	4	4809335	Washer SRKB Ø9x35x3 FZB
9	4	82108000	Washer M8 FZB
10	1	M102506	Engine assembly 2 - TMP

441095 Exhaust for SS hydra

441095 Exhaust gasket GS 140-200

Break all edges

This document is strictly confidential and must not be accounted for copied or disclosed to any third person. HEDENSTED GRUPPEN A/S	HG	Scale:	Not specified tolerance according to:	Sheet size:
	HEDENSTED GRUPPEN	1 : 4	DS/ISO 2768-m	A3
	Part No.:		Surface properties:	Sheet:
	M102505		No	1 / 1
Description 1:		Engine assembly 3 TMP		
Description 2:				

Revision:	Approved	Date:	Revision Description
1	KL	08-02-2016	Made

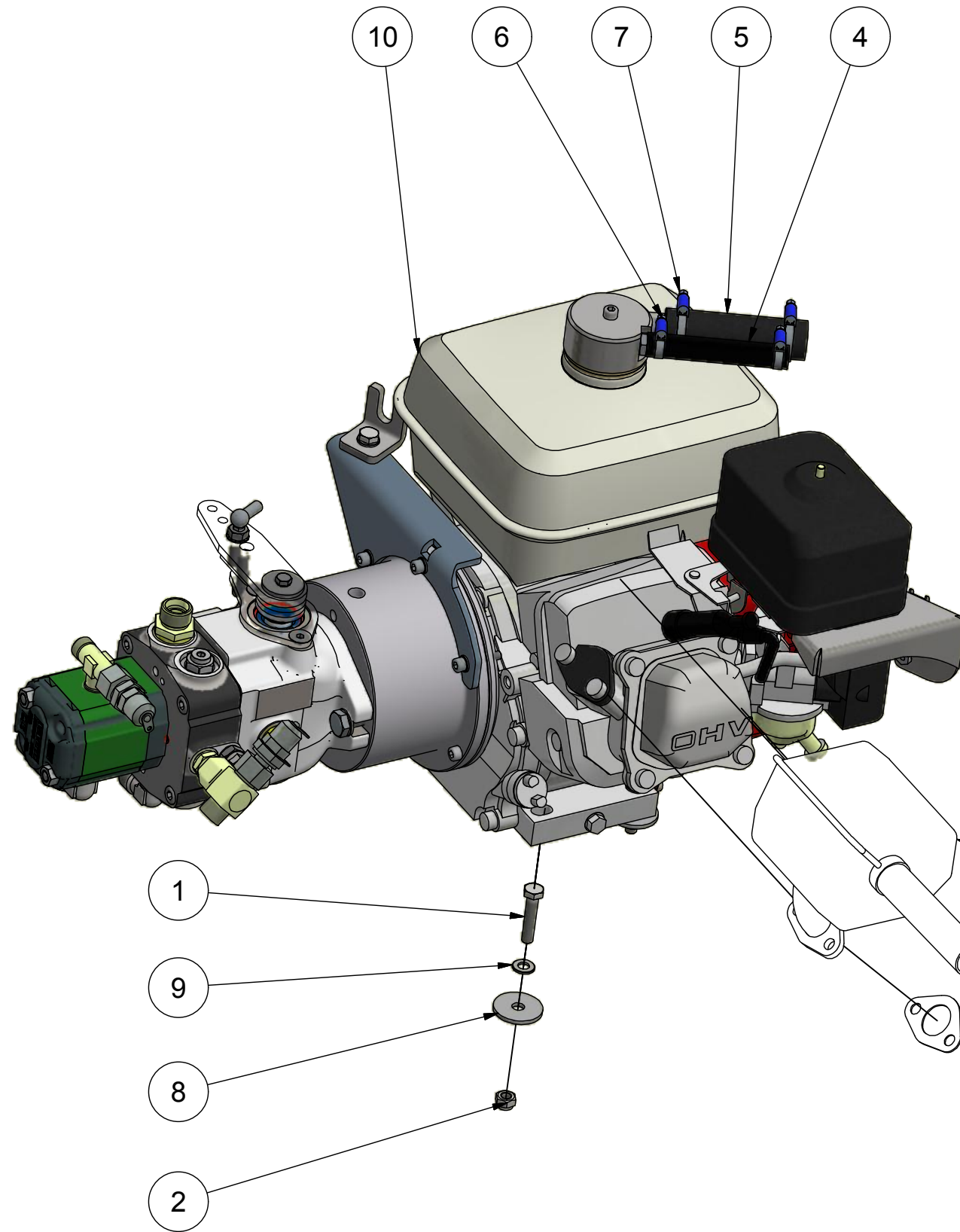

PARTS LIST			
ITEM	QTY	PART NUMBER	DESCRIPTION
1	4	11408040	Hexagon bolt M8x40 FZB
2	4	17908000	Self-locking nut M8 FZB
3	1	423420	Pipe for exhaust
4	0,6 m	423451	Fuel hose hydro eco 10x3,5
5	0,6 m	423452	Fuel hose 19x6,0
6	2	474006	Hose clamp 11-16
7	2	474008	Hose clamp 22-30
8	4	4809335	Washer SRKB Ø9x35x3 FZB
9	4	82108000	Washer M8 FZB
10	1	M102506	Engine assembly 2 - TMP

441095 Exhaust for SS hydra

441095 Exhaust gasket GS 140-200

Break all edges

<small>This document is strictly confidential and must not be accounted for copied or disclosed to any third person.</small> HEDENSTED GRUPPEN A/S	HG	Scale:	Not specified tolerance according to:	Sheet size:
	<small>HEDENSTED GRUPPEN</small>	1 : 4	DS/ISO 2768-m	A3
	Part No.:		Surface properties:	Sheet:
	M102505		No	1 / 1
Description 1:		Material:		
Engine assembly 3 TMP				
Description 2:				

Revision:	Approved	Date:	Revision Description
2	KL	19-04-2017	Brace for morse cable changed

PARTS LIST

ITEM	QTY	PART NUMBER	DESCRIPTION
1	6	10206020	Hexagon cylinder head M6x20 FZB
2	2	11410030	Hexagon bolt M10x30 FZB
3	4	20408025	Hexagon countersunk head M8x25 FZB
4	1	422659	Engine assembly 1
5	1,7 m	423470	Starter string 4,5 mm (1,58m)
6	1	423487	Centrifugal clutch w. housing
7	0,6 l	476705	Engine oil Q8 T520 15W-40
8	2	82110000	Washer M10 FZB
9	1	M102507	Hydraulic pump assembly TMP pump

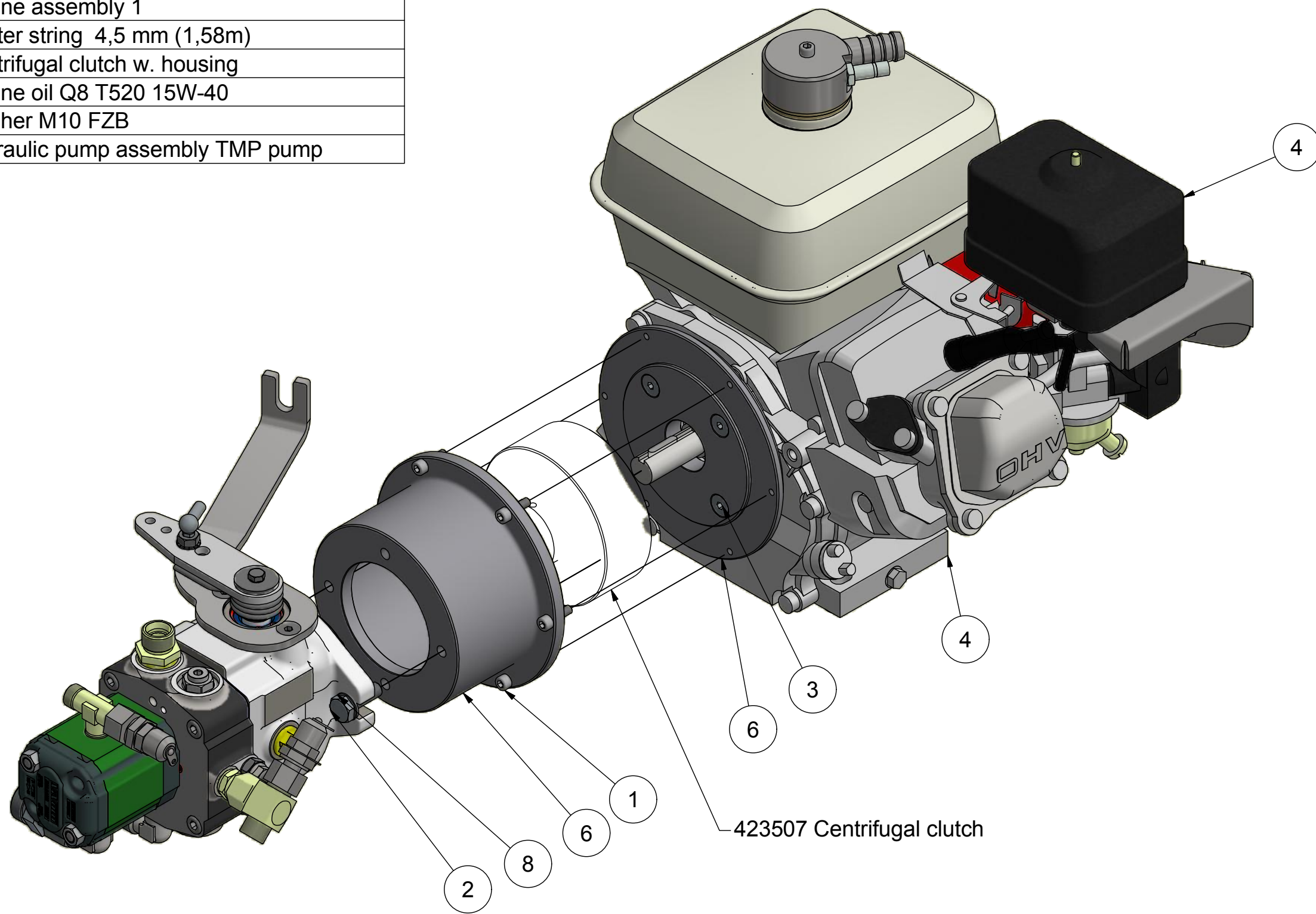

Break all edges

This document is strictly confidential and must not be copied, reproduced, or disclosed to any third person. HEDENSTED GRUPPEN A/S		Scale: 1:3	Not specified tolerance according to: DS/ISO 2768-m	Sheet size: A3
	HEDENSTED GRUPPEN		Surface properties: No	Sheet: 1 / 1
	Part No.: M102507	Material:		
	Description 1: Engine assembly 2 - TMP			
Description 2:				

Revision:	Approved	Date:	Revision Description
1	HG	08-02-2016	KL

PARTS LIST

ITEM	QTY	PART NUMBER	DESCRIPTION
1	3	10206020	Hexagon cylinder head M6x20 FZB
2	3	10206030	Hexagon cylinder head M6x30 FZB
3	1	11408025	Hexagon bolt M8x25 FZB
4	2	11410030	Hexagon bolt M10x30 FZB
5	1	17908000	Self-locking nut M8 FZB
6	4	20408025	Hexagon countersunk head M8x25 FZB
7	1	422659	Engine assembly 1
8	1,7 m	423470	Starter string 4,5 mm (1,58m)
9	1	423487	Centrifugal clutch w. housing
10	0,6 l	476705	Engine oil Q8 T520 15W-40
11	3	82106000	Washer M6 FZB
12	2	82108000	Washer M8 FZB
13	2	82110000	Washer M10 FZB
14	1	82608000	Washer Ø8,4x24x2 FZB
15	1	M102507	Hydraulic pump assembly TMP pump
16	1	M102605	Brace for steering cable
17	1	M102606	Arm for steering cable

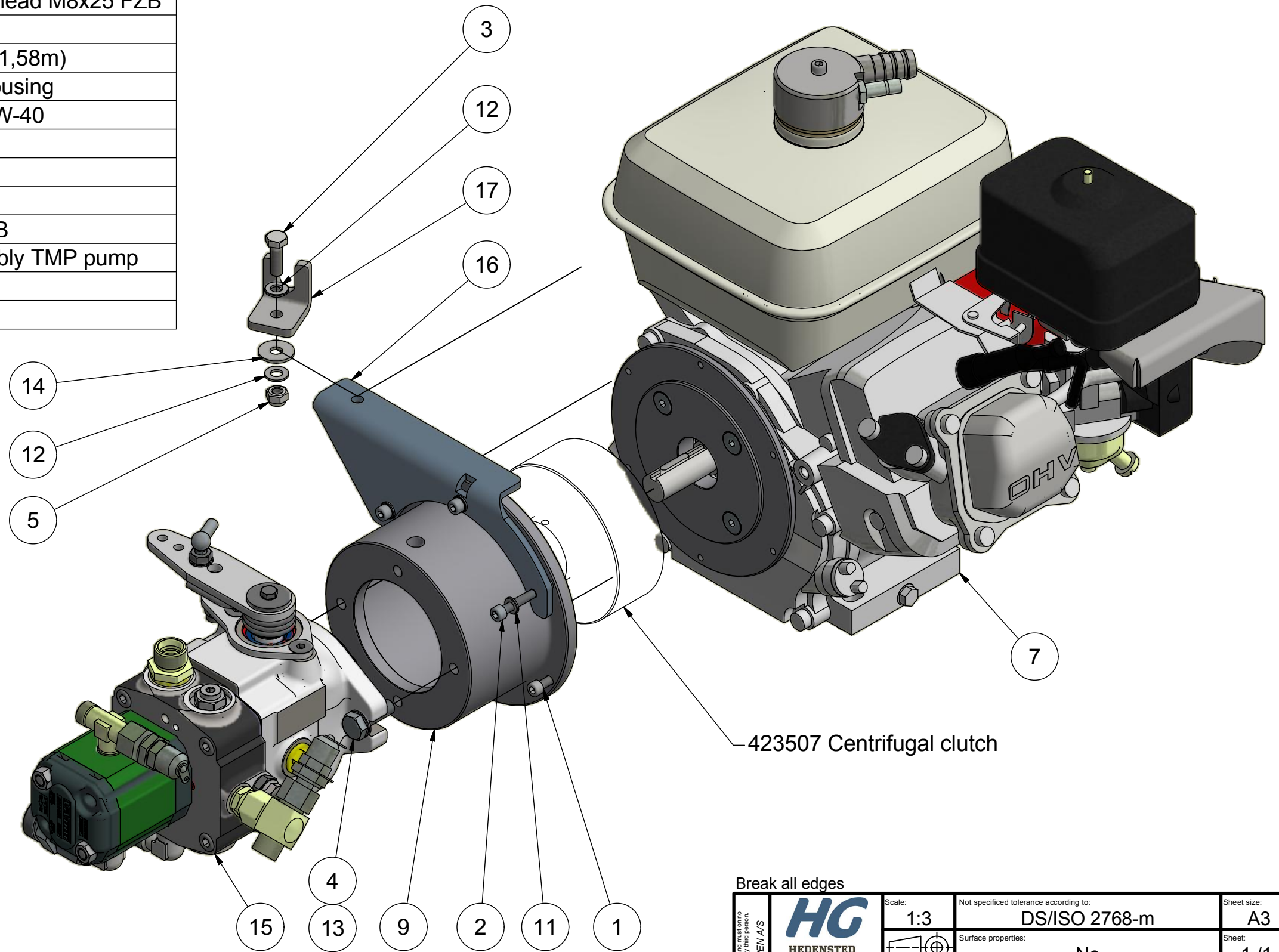

Break all edges

This document is strictly confidential and must not be accounted for copied or disclosed to any third person. HEDENSTED GRUPPEN A/S	 HEDENSTED GRUPPEN	Scale: 1:3	Not specified tolerance according to: DS/ISO 2768-m	Sheet size: A3
	Part No.: M102506	Material:	Surface properties: No	Sheet: 1 / 1
Description 1: Engine assembly 2 - TMP		Description 2:		

Revision:	Approved	Date:	Revision Description
2	KL	19-04-2017	Brace for morse cable changed

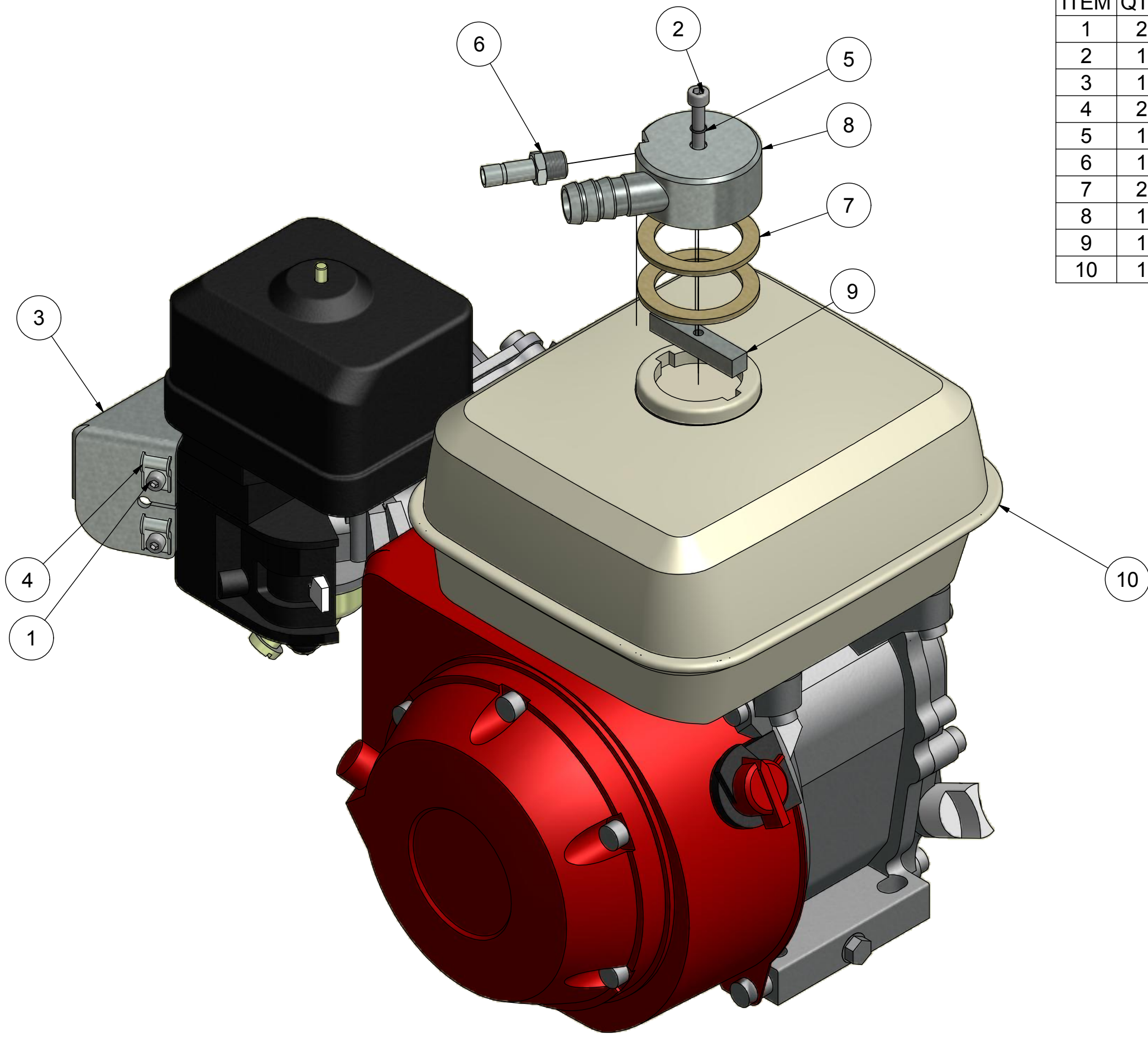

PARTS LIST			
ITEM	QTY	PART NUMBER	DESCRIPTION
1	2	10205010	Hexagon cylinder head M5x10 FZB
2	1	10206050	Hexagon cylinder head M6x50 FZB
3	1	423415	Throttle-Choke brace
4	2	423419	Cable clamp
5	1	423444	O-ring OR6,00-1,00
6	1	423446	Reduction stem Ø10 x 1/4" pipe Metal
7	2	423627	Gasket for fueltank
8	1	43356	External fuel cap
9	1	43359	Tension brace
10	1	441705	HONDA GX200UT SXE5 electrical start

Break all edges

The document is strictly confidential and must not be accounted for copied or disclosed to any third person. HEDENSTED GRUPPEN A/S	HG	Scale:	Not specified tolerance according to:	Sheet size:
	HEDENSTED GRUPPEN	1 : 2	DS/ISO 2768-m	A3
	Part No.:		Surface properties:	Sheet:
	422659		No	1 / 2
Description 1:		Material:		
Engine assembly 1				
Description 2:				

Revision:	Approved	Date:	Revision Description
1	HG	27-09-2015	Revision changed to numeric

Parts List

ITEM	QTY	PART NUMBER	DESCRIPTION
1	1	424176	Tee 3/8"t x Ø12L x Ø12L (M/F/F)
2	1	477097	Straight connector w. gasket 3/8" x 3/4"
3	1	477110	Straight connector w. gasket Ø12L x 1/4"
4	1	477120	Straight connector w. gasket Ø15L 1/2"
5	1	477141	Elbow 1/2"t x Ø15L
6	1	477146	Elbow 3/8"t x Ø15L
7	1	477163	Bopnded seal washer 3/8"
8	1	477208	Reduction Ø15L w. o-ring Ø22L
9	2	477272	Test nipple w. o-ring Ø12L
10	1	489103	Ball angle joint AS08 M05
11	1	M101761	Tee adjustable Ø12L x Ø12L w. o-ring x Ø12L
12	1	M101762	Variable piston pump 13,6ccm
13	1	M101763	Gear pump 3,8ccm, German standard ø32
15	1	M101765	Brace for morse cable

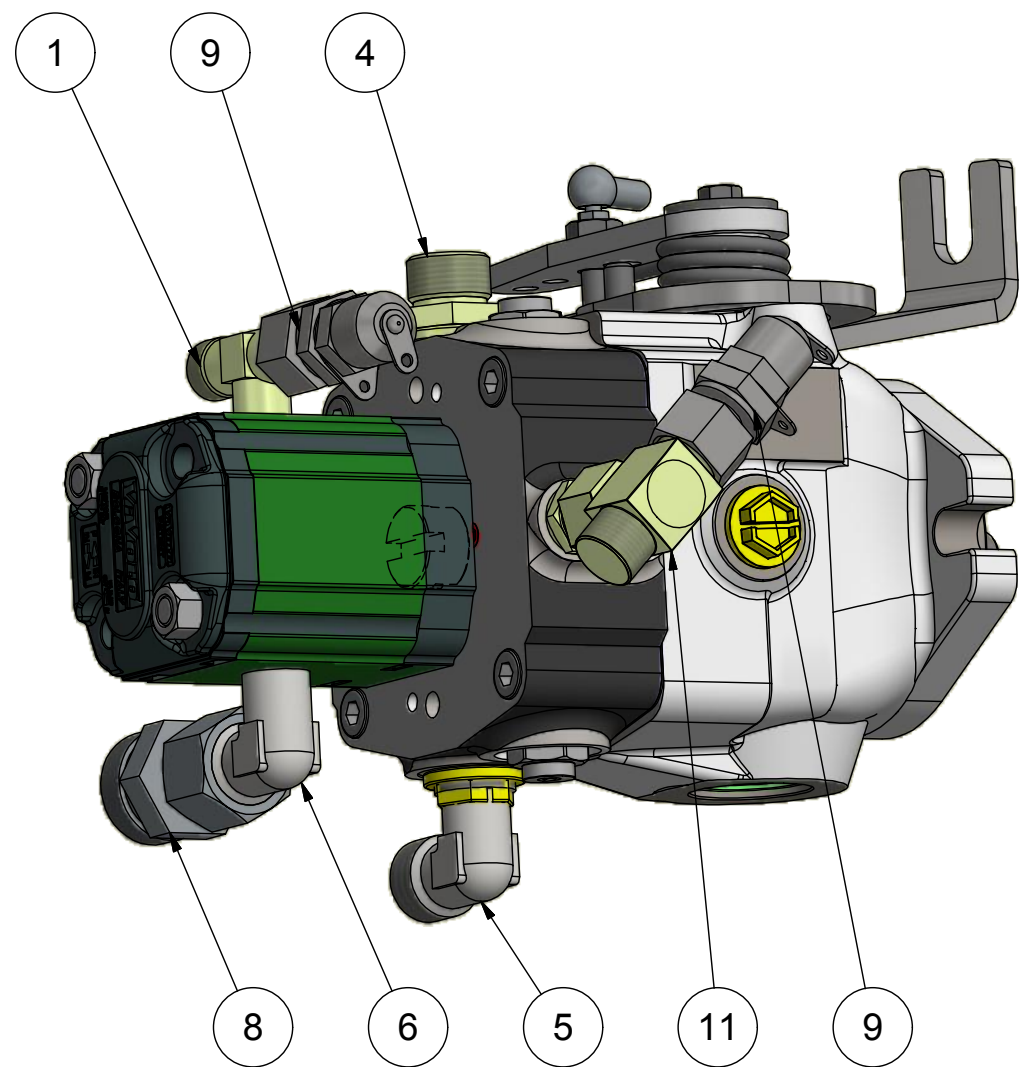
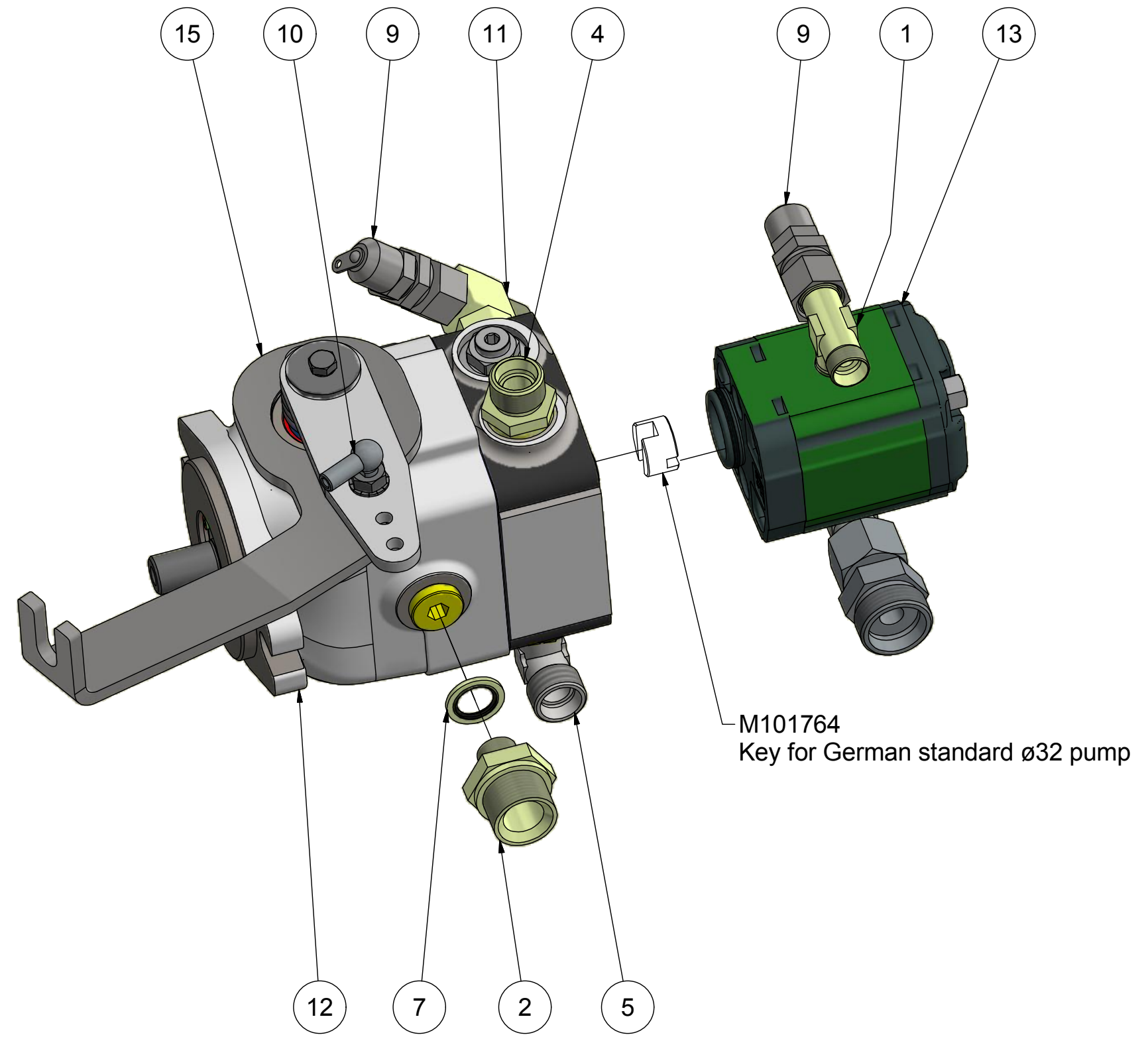

Revision:	Approved	Date:	Revision Description
1	HG	08-02-2016	Made

Break all edges

 HEDENSTED GRUPPEN	Scale: 1 : 2	Not specified tolerance according to: DS/ISO 2768-m	Sheet size: A3
		Surface properties:	Sheet: 1 / 2
Part No.:	M102507		
Description 1:	Hydraulic pump assembly TMP pump		
Description 2:			

This document is strictly confidential and must not be accounted for copied or disclosed to any third person.
HEDENSTED GRUPPEN A/S

Parts List

ITEM	QTY	PART NUMBER	DESCRIPTION
1	1	424176	Tee 3/8"t x Ø12L x Ø12L (M/F/F)
2	1	477097	Straight connector w. gasket 3/8" x 3/4"
3	1	477110	Straight connector w. gasket Ø12L x 1/4"
4	1	477120	Straight connector w. gasket Ø15L 1/2"
5	1	477141	Elbow 1/2"t x Ø15L
6	1	477146	Elbow 3/8"t x Ø15L
7	1	477163	Bopnded seal washer 3/8"
8	1	477208	Reduction Ø15L w. o-ring Ø22L
9	2	477272	Test nipple w. o-ring Ø12L
10	1	489103	Ball angle joint AS08 M05
11	1	M101761	Tee adjustable Ø12L x Ø12L w. o-ring x Ø12L
12	1	M101762	Variable piston pump 13,6ccm
13	1	M101763	Gear pump 3,8ccm, German standard ø32
14	1	M101764	Key for German standard ø32 pump

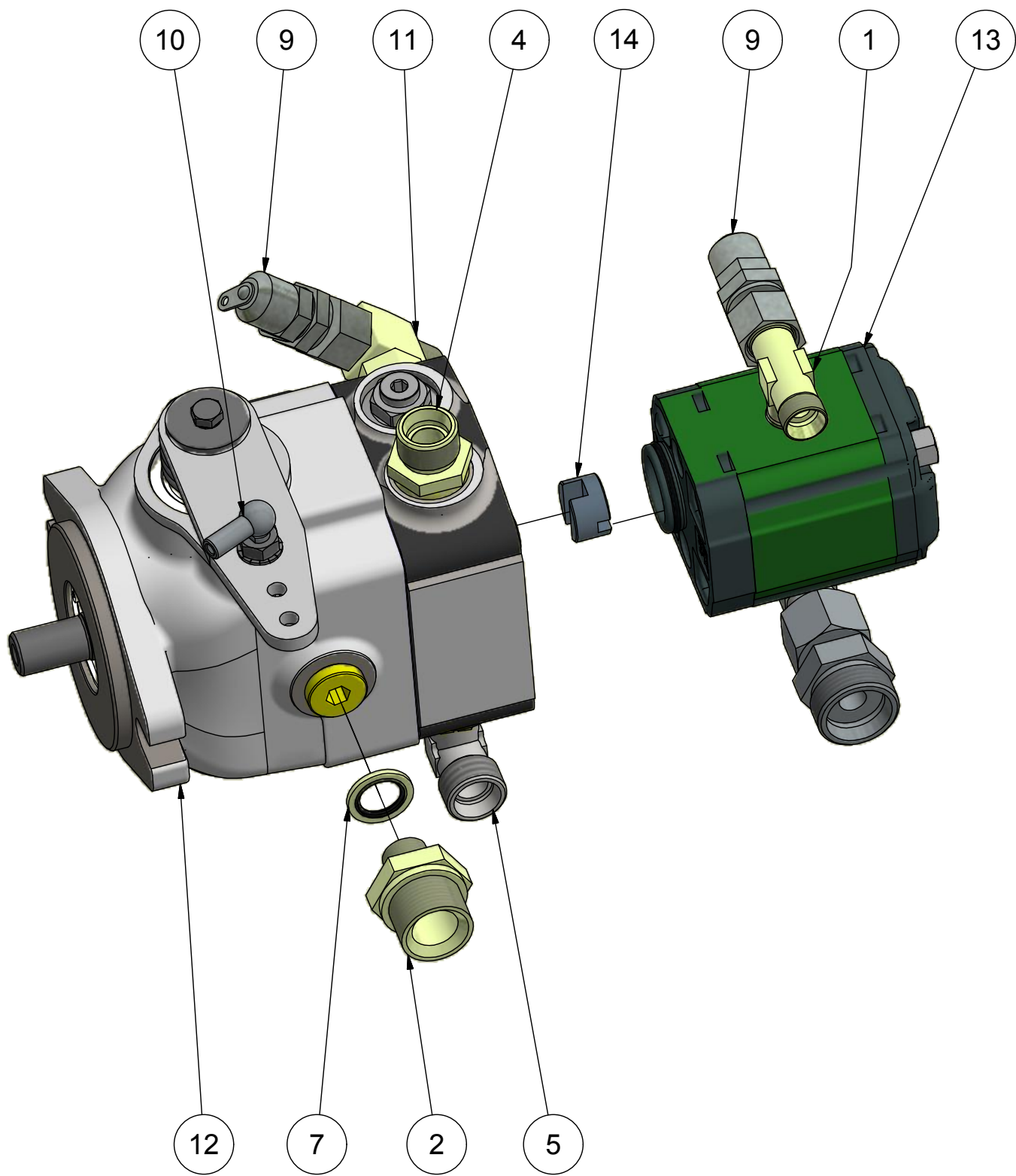
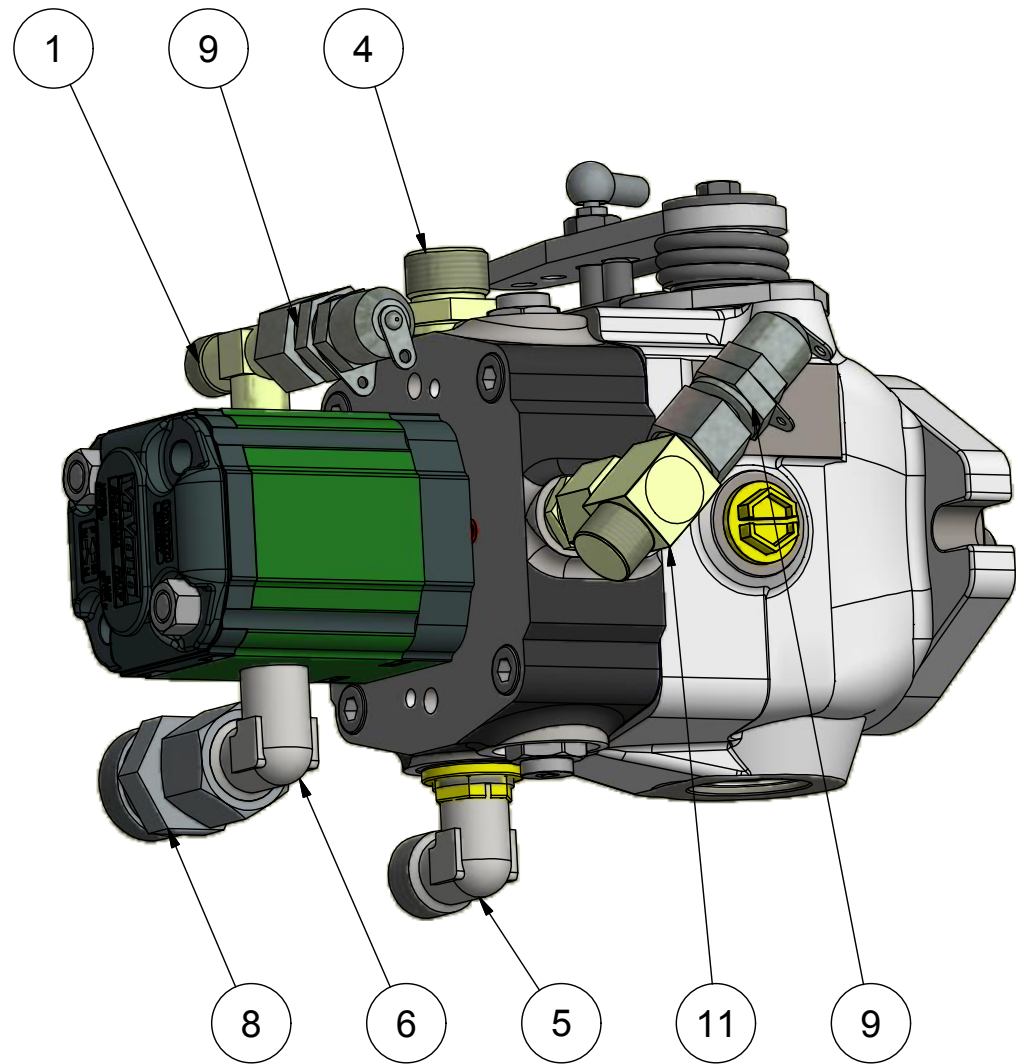

Break all edges

The documents strictly confidential and must not be accounted by copied or disclosed to any third person. HEDENSTED GRUPPEN A/S	 HEDENSTED GRUPPEN	Scale: 1 : 2	Not specified tolerance according to: DS/ISO 2768-m	Sheet size: A3
	Part No.: M102507	Surface properties:		Sheet: 1 / 2
	Description 1: Hydraulic pump assembly TMP pump			
	Description 2:			

Revision:	Approved	Date:	Revision Description
2	HG	09-02-2016	M101765 Brace for morse cable removed

PARTS LIST			
ITEM	QTY	PART NUMBER	DESCRIPTION
1	2	10206012	Hexagon cylinder head M6x12 FZB
2	2	11416150	Hexagon bolt M16x150 FZB
3	2	17916000	Self-locking nut M16 FZB
4	4	20412030	Hexagon countersunk head M12x30 FZB
5	1	280140	Wheel suspension
6	2	423068	Grease nipple M6 straight
7	2	423465	Fork for wheel
8	2	423466	Tire with rim Ø268xØ12,5x120
9	2	82106000	Washer M6 FZB

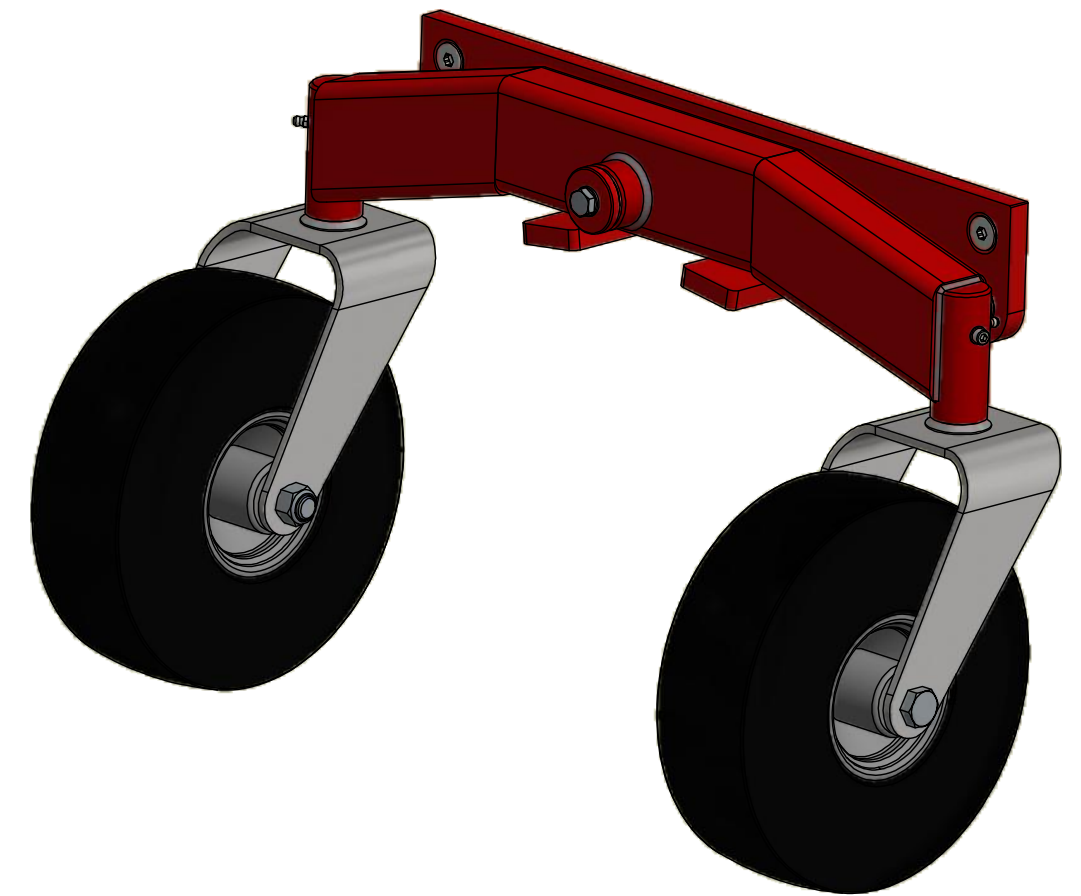
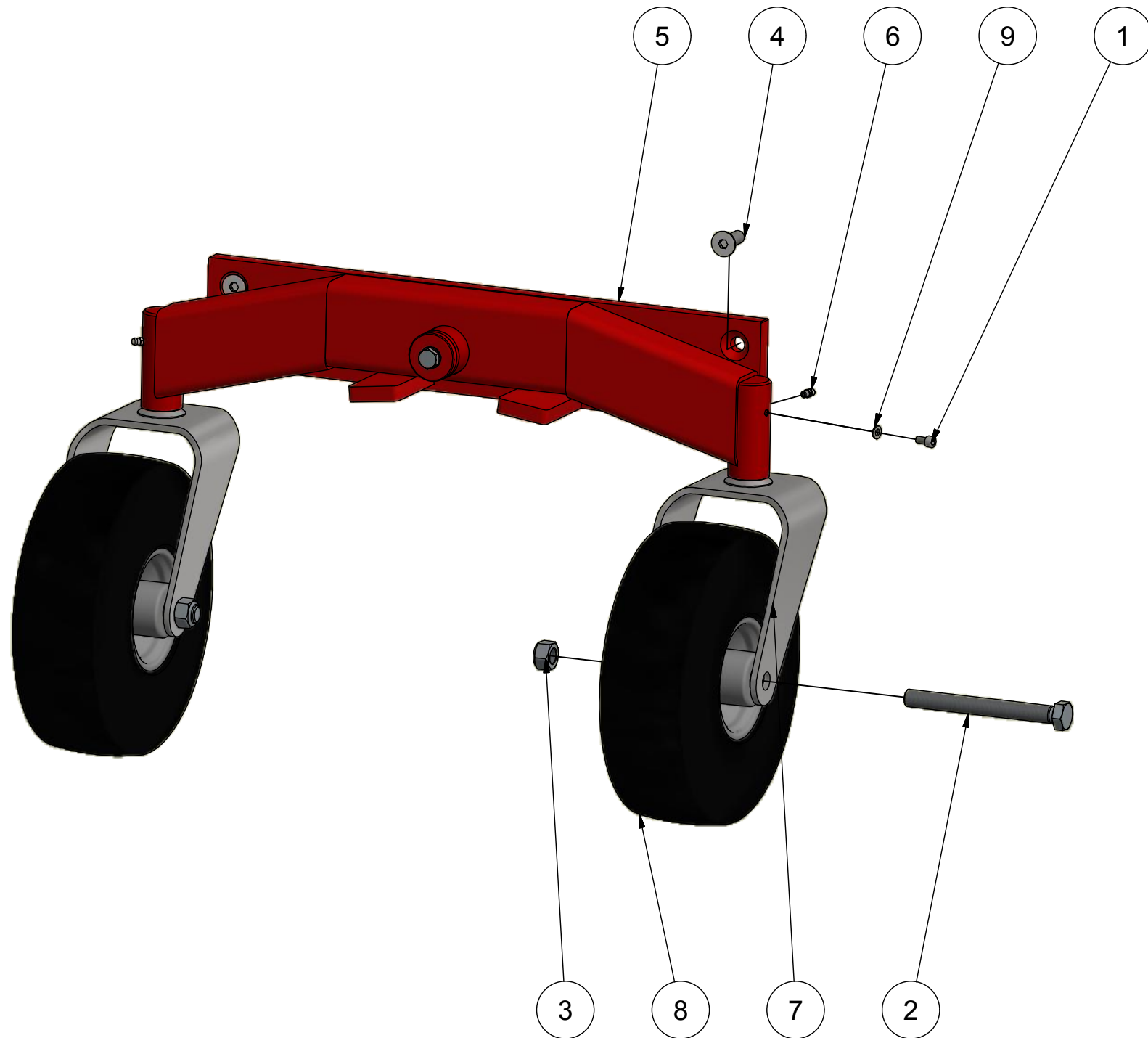

Break all edges

The document is strictly confidential and must not be accounted for copied or disclosed to any third person. HEDENSTED GRUPPEN A/S	 HEDENSTED GRUPPEN	Scale: 1 : 5	Not specified tolerance according to: DS/ISO 2768-m	Sheet size: A3
	Part No.: M12110	Material:	Surface properties: No	Sheet: 1 / 1
	Description 1: Wheel suspension assembly			
	Description 2:			

Revision:	Approved	Date:	Revision Description
1	SK	22-09-2016	Made

Parts List			
ITEM	QTY	PART NUMBER	DESCRIPTION
1	1	280139	Wheel suspension, movable part
2	1	280138	Wheel suspension, base part
3	1	43254	End plate Ø45
4	1	11410030	Hexagon bolt M10x30 FZB
5	1	82110000	Chamfered Washer M10 FZB
6	2	422413	Slide Bearing PAF-30260 (34x30x26)

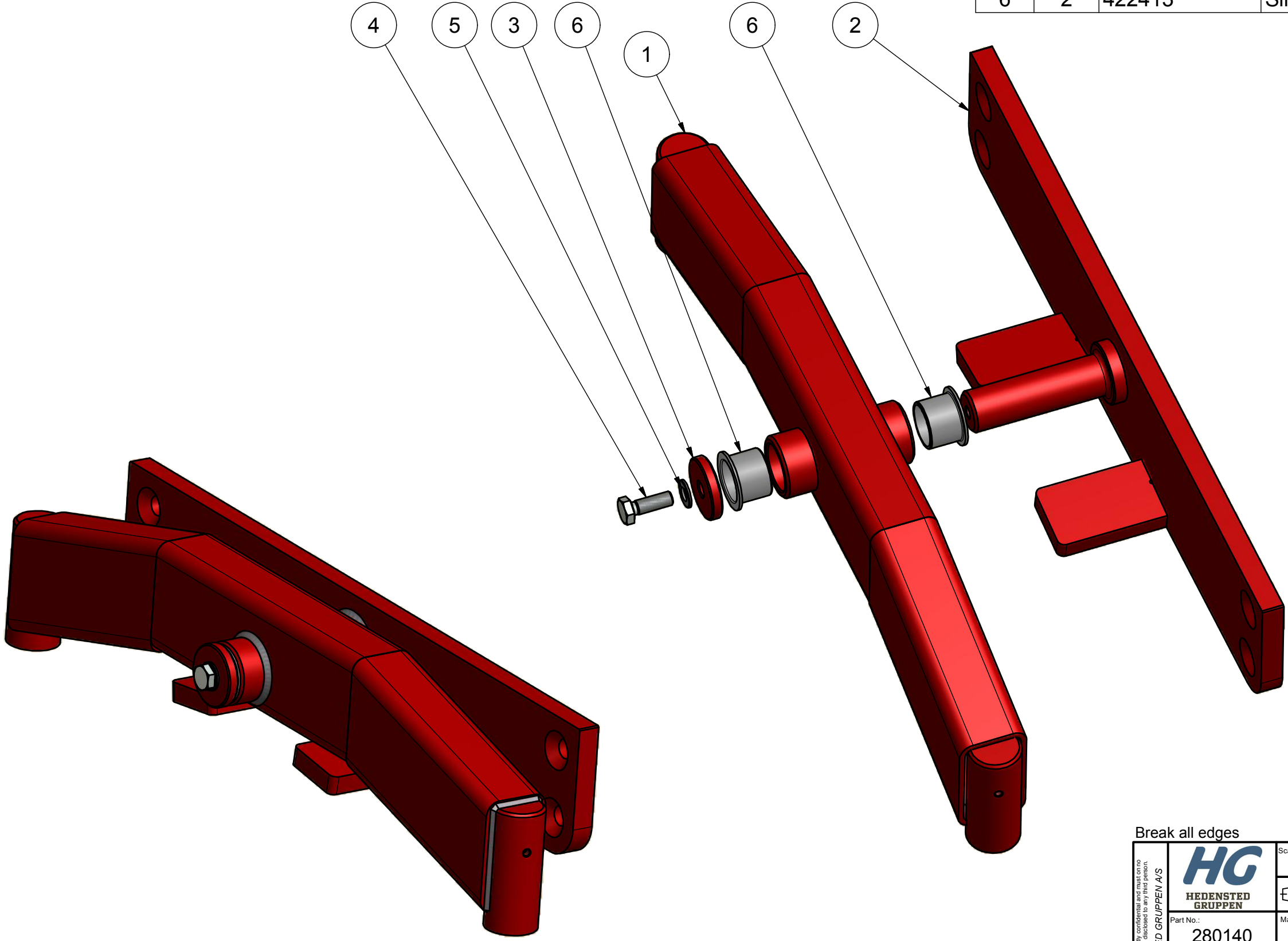

Break all edges

The document is strictly confidential and must not be accounted for copied or disclosed to any third person. HEDENSTED GRUPPEN A/S	HG	Scale: 1 : 3	Not specified tolerance according to: DS/ISO 2768-m	Sheet size: A3
	HEDENSTED GRUPPEN		Surface properties:	Sheet: 1 / 1
	Part No.: 280140		Material:	
	Description 1: Wheel suspension		Description 2: Without fork & wheels (Rem. bolts)	

Revision:	Approved	Date:	Revision Description
1	HG	28-09-2015	Revision changed to numeric