



Spare parts



280133 Hydra Combi

HG
HEDENSTED
GRUPPEN

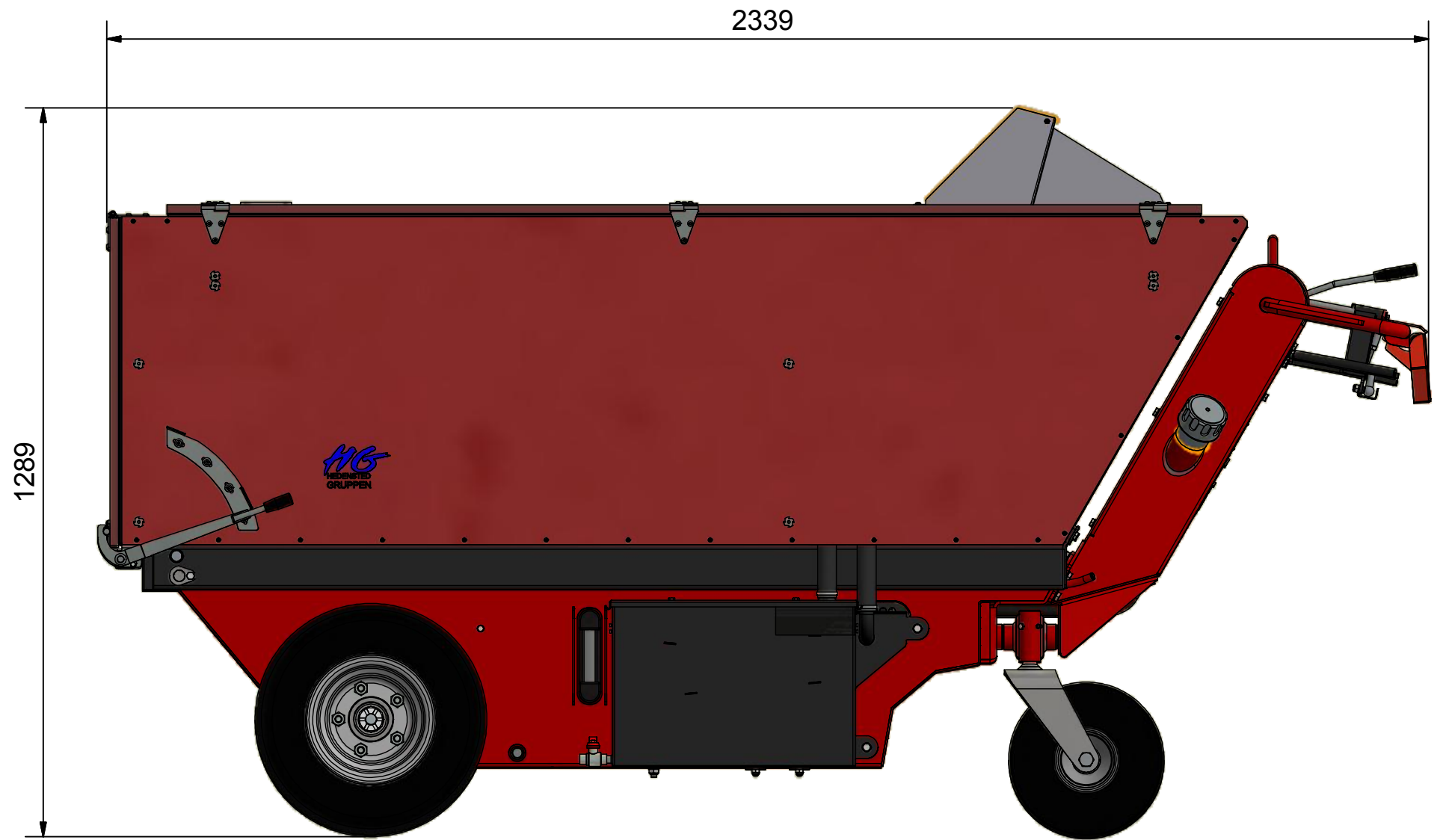
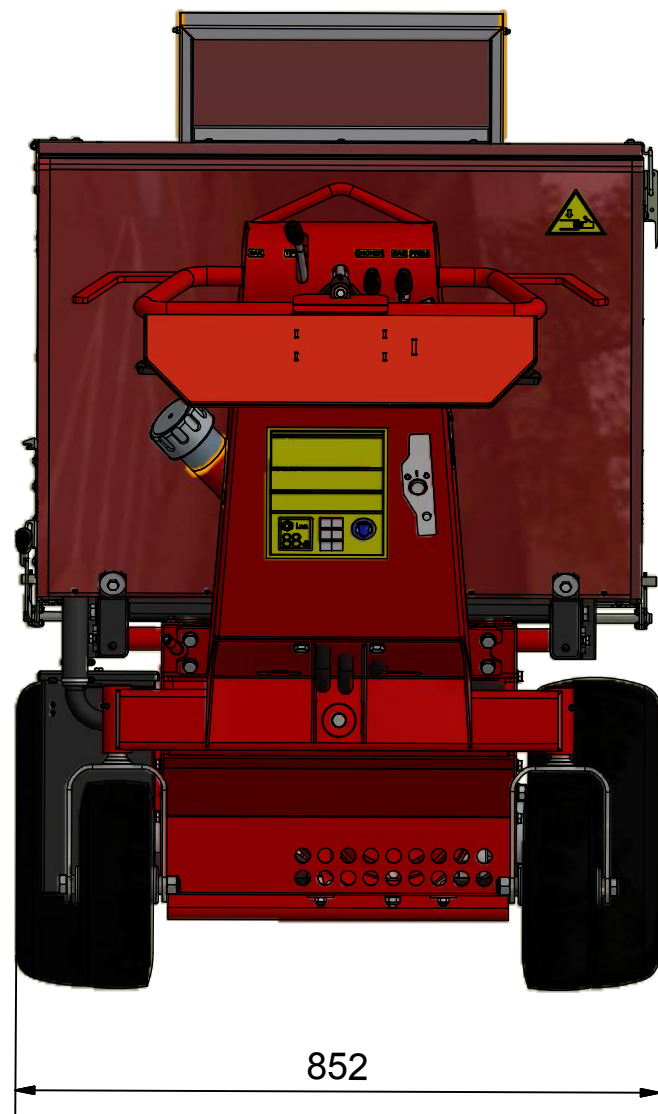

Break all edges

The document is strictly confidential and must not be accounted for copied or disclosed to any third person. HEDENSTED GRUPPEN A/S	 HEDENSTED GRUPPEN	Scale: 1 : 10	Not specified tolerance according to:	Sheet size: A3
	Part No.: 280133	Material:	Surface properties:	Sheet: 1 / 2
Description 1: Hydra combi with killingbox				
Description 2: W/ elect. Start				

Revision:	Approved	Date:	Revision Description
1	HG	28-09-2015	Revision changed to numeric

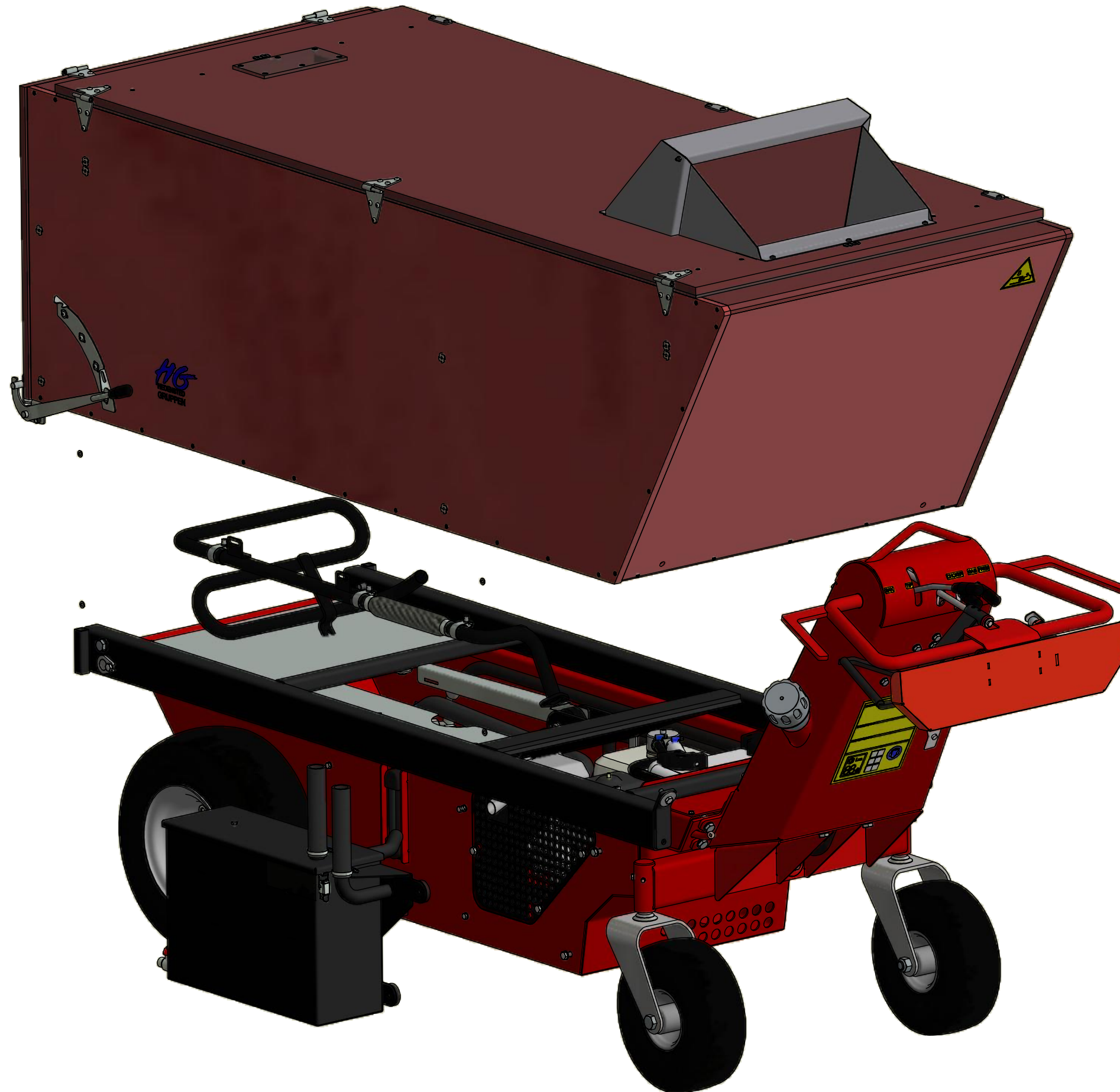

Parts List			
ITEM	QTY	PART NUMBER	DESCRIPTION
1	1	422558	Frame part 10
2	1	441805	Exhaust for Hydra combi
3	3	11408016	Hexagon bolt M8x16 FZB
4	3	82108000	Washer M8 FZB

Wrap the parts in plastic
put inside box

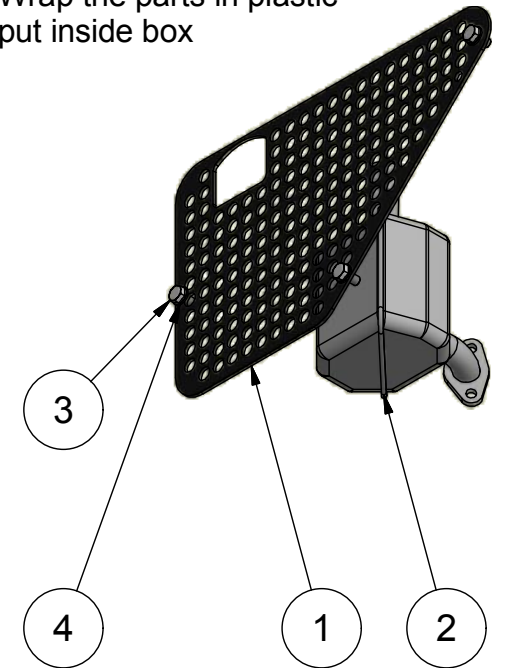

Parts List			
ITEM	QTY	PART NUMBER	DESCRIPTION
1	1	280134	HG S.S. Hydra Combi electrical
2	1	280150	Killing box 120 males
3	5,0 l	476505	Gasoline 95 unleaded

Revision:	Approved	Date:	Revision Description
1	HG	28-09-2015	Revision changed to numeric

Break all edges

The documents strictly confidential and must not be accounted for copied or disclosed to any third person. HEDENSTED GRUPPEN A/S	 HEDENSTED GRUPPEN	Scale: 1 : 10	Not specified tolerance according to:	Sheet size: A3
	Part No.:	Material:	Surface properties:	Sheet: 2 / 2
	Description 1: Loose parts			
	Description 2:			

Parts List

ITEM	QTY	PART NUMBER	DESCRIPTION
1	3	11408016	Hexagon bolt M8x16 FZB
2	1	422558	Frame part 10
3	1	422674	Stand assembly
4	1	422686	Third base assembly
5	1	441805	Exhaust for Hydra combi
6	14,0 l	476721	Hydraulic oil Q8 handel 46
7	3	82108000	Washer M8 FZB

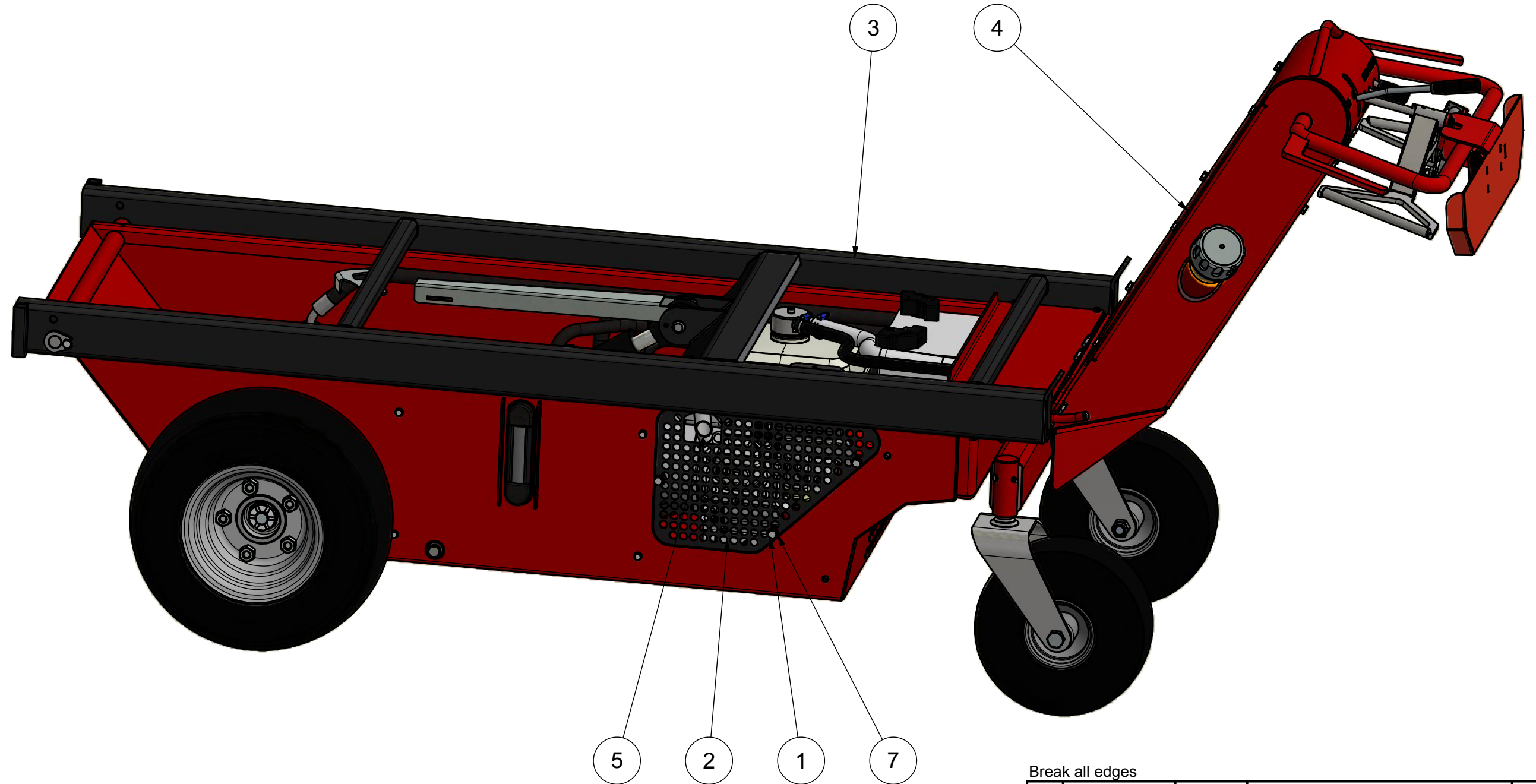

Break all edges

The document is strictly confidential and must not be accounted for copied or disclosed to any third person. HEDENSTED GRUPPEN A/S	 HEDENSTED GRUPPEN	Scale: 1 : 7	Not specified tolerance according to: DS/ISO 2768-m	Sheet size: A3
	Part No.: 280134	Material:	Surface properties:	Sheet: 1 / 1
Description 1: HG S.S. Hydra Combi electrical				
Description 2: start				

Revision:	Approved	Date:	Revision Description
1	HG	28-09-2015	Revision changed to numeric

Parts List

ITEM	QTY	PART NUMBER	DESCRIPTION
1	4	11405012	Hexagon bolt M5x12 FZB
2	4	11408040	Hexagon bolt M8x40 FZB
3	4	17908000	Self-locking nut M8 FZB
4	1	17910000	Self-locking nut M10 FZB
5	1	422556	Frame part 6
6	1	422562	Frame part 17
7	1	422564	Frame assembly 1
8	1	422652	Red wire 16° Length 80 cm
9	1	422654	Black wire length 98 cm
10	1	422656	Wiring for Engine
11	1	422660	Engine assembly 2
12	1	422676	Battery assembly
13	1	422678	Operator assembly
14	1	422680	Suspension assembly
15	1	423421	Vibration absorber Ø65x35 - M10
16	0,9 m	423451	Fuel hose hydro eco 10x3,5
17	0,9 m	423452	Fuel hose 19x6,0
18	1	423477	Warning logo DK
19	1	423542	Washer for vibration absorber
20	2	423606	Rubber plug for plate
21	2	474007	Hose clamp 14-22
22	2	474008	Hose clamp 22-30
23	4	4809335	Washer SRKB Ø9x35x3 FZB
24	4	82105900	Washer M5 FZB
25	4	82108000	Washer M8 FZB
26	1	82110000	Washer M10 FZB

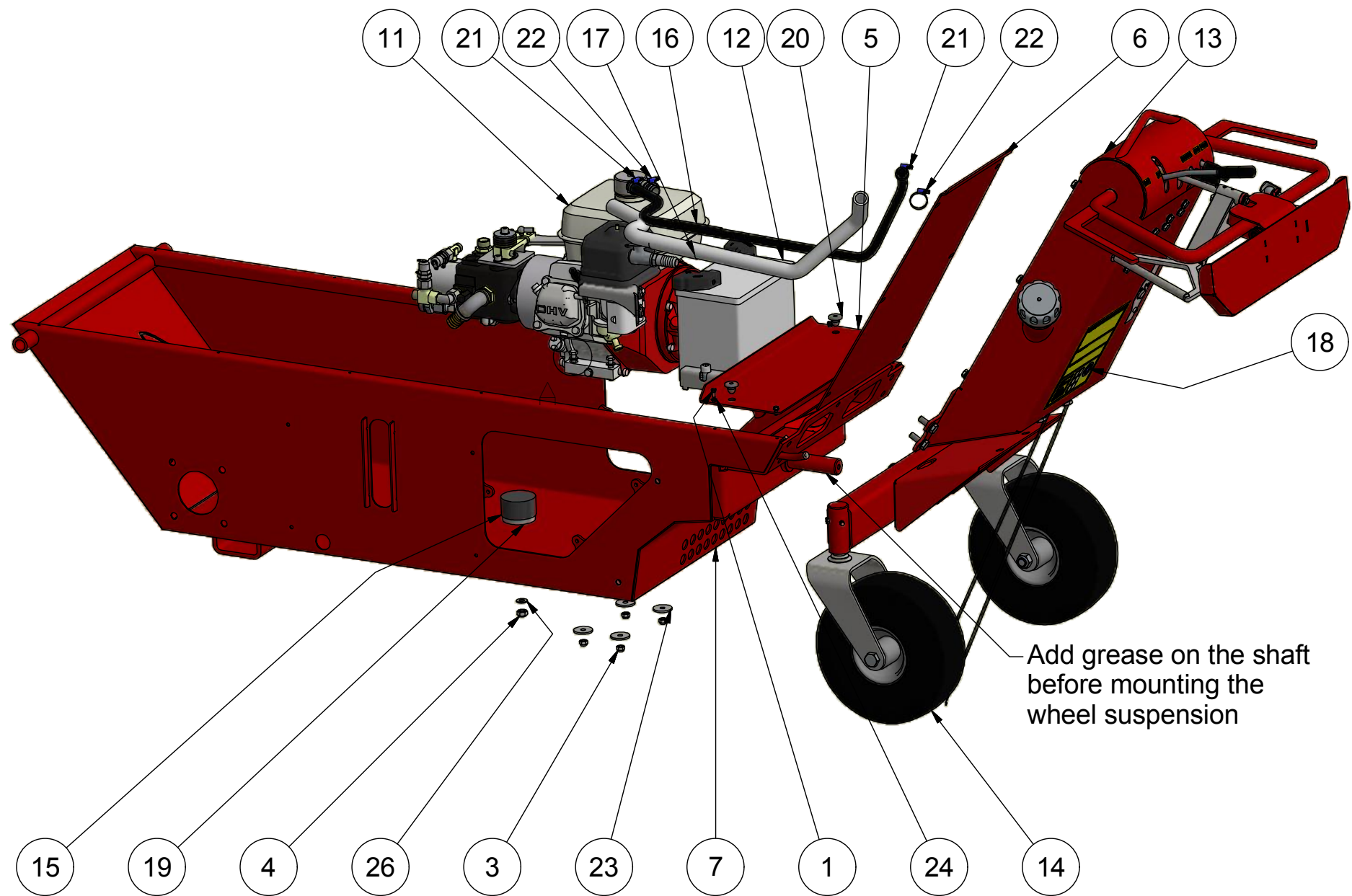

A < 1 : 2 >

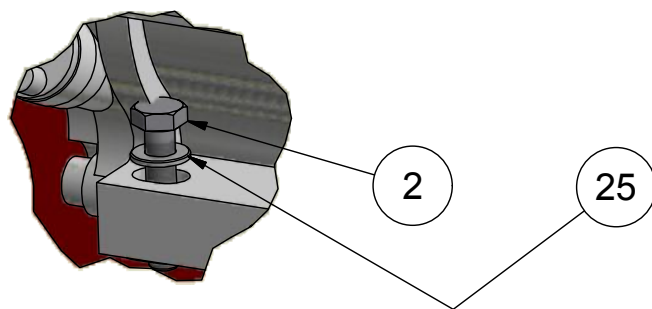

Revision:	Approved	Date:	Revision Description
1	HG	28-09-2015	Revision changed to numeric

Break all edges

The documents strictly confidential and must not be accounted for copied or disclosed to any third person. HEDENSTED GRUPPEN A/S		Scale:	Not specified tolerance according to:	Sheet size:
	HEDENSTED GRUPPEN	1 : 10		A3
Part No.:	Material:		Surface properties:	Sheet:
422682				1 / 2
Description 1:				
First base assembly				
Description 2:				

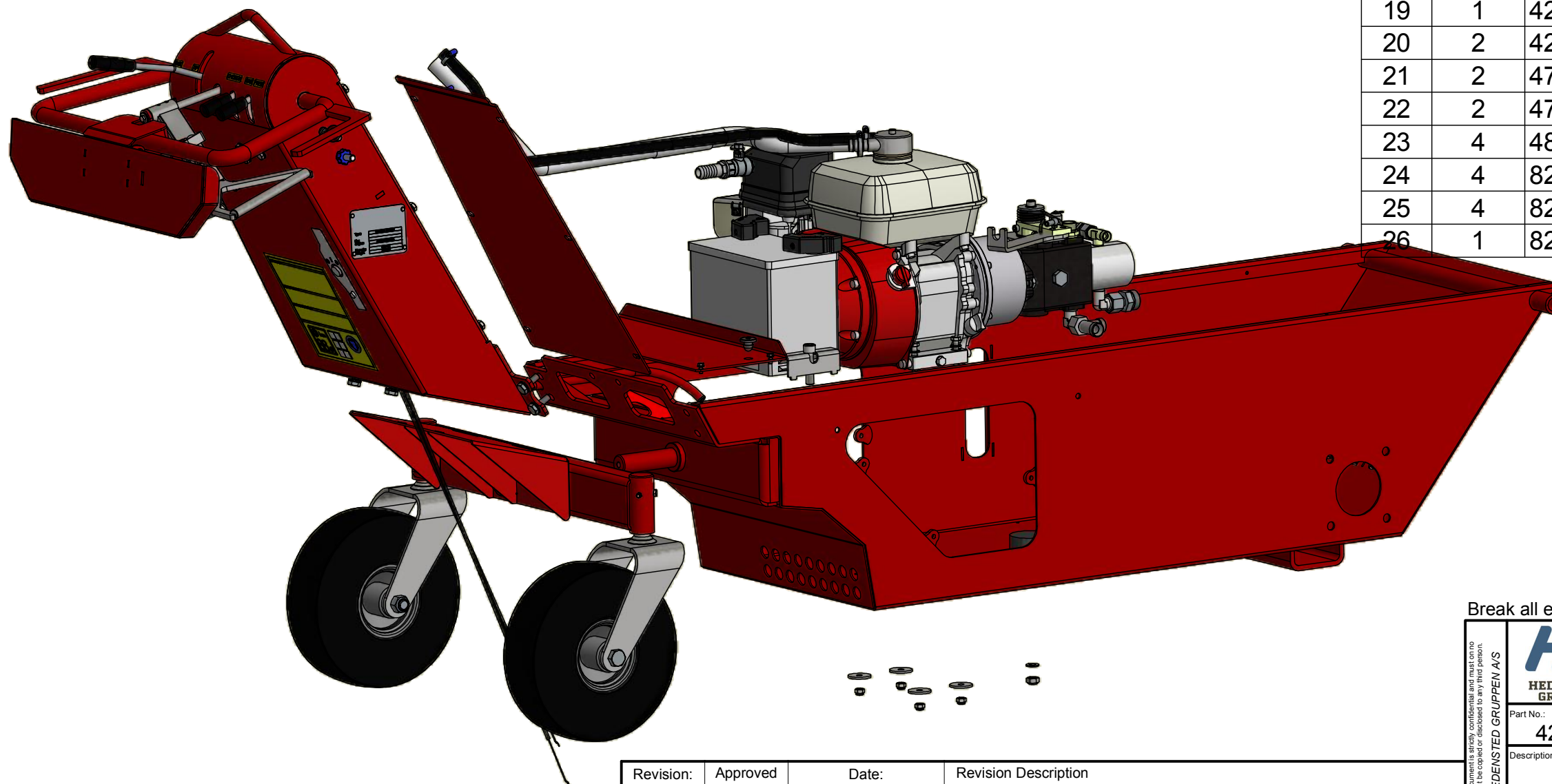

Parts List

ITEM	QTY	PART NUMBER	DESCRIPTION
1	4	11405012	Hexagon bolt M5x12 FZB
2	4	11408040	Hexagon bolt M8x40 FZB
3	4	17908000	Self-locking nut M8 FZB
4	1	17910000	Self-locking nut M10 FZB
5	1	422556	Frame part 6
6	1	422562	Frame part 17
7	1	422564	Frame assembly 1
8	1	422652	Red wire 16° Length 80 cm
9	1	422654	Black wire length 98 cm
10	1	422656	Wiring for Engine
11	1	422660	Engine assembly 2
12	1	422676	Battery assembly
13	1	422678	Operator assembly
14	1	422680	Suspension assembly
15	1	423421	Vibration absorber Ø65x35 - M10
16	0,9 m	423451	Fuel hose hydro eco 10x3,5
17	0,9 m	423452	Fuel hose 19x6,0
18	1	423477	Warning logo DK
19	1	423542	Washer for vibration absorber
20	2	423606	Rubber plug for plate
21	2	474007	Hose clamp 14-22
22	2	474008	Hose clamp 22-30
23	4	4809335	Washer SRKB Ø9x35x3 FZB
24	4	82105900	Washer M5 FZB
25	4	82108000	Washer M8 FZB
26	1	82110000	Washer M10 FZB

Break all edges

The document is strictly confidential and must not be accounted for copied or disclosed to any third person. HEDENSTED GRUPPEN A/S		Scale: 1 : 10	Not specified tolerance according to:	Sheet size: A3
	Part No.: 422682	Material:	Surface properties:	Sheet: 2 / 2
	Description 1: First base assembly			
	Description 2:			

Revision:	Approved	Date:	Revision Description
1	HG	28-09-2015	Revision changed to numeric

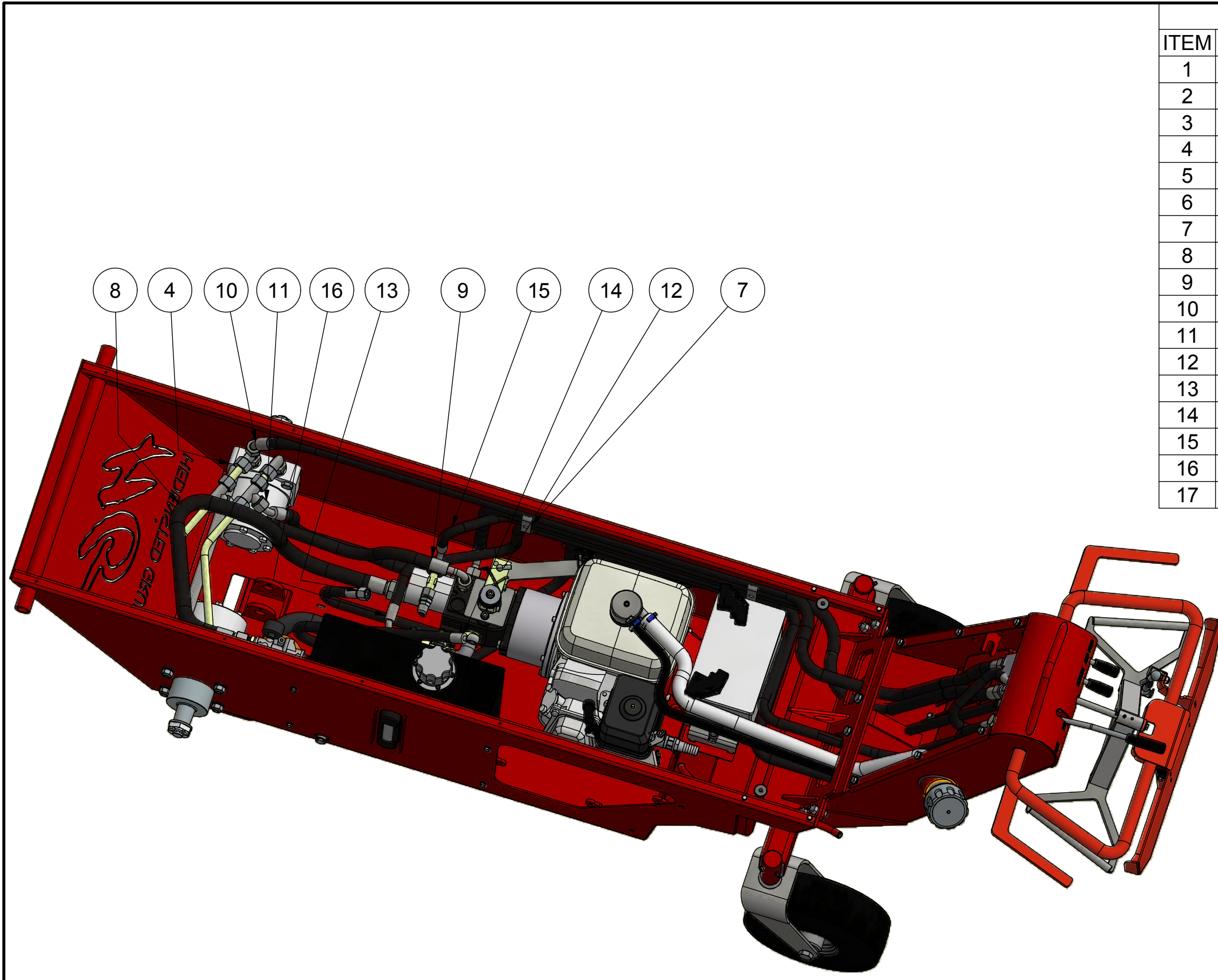

Parts List			
ITEM	QTY	PART NUMBER	DESCRIPTION
1	3	11408012	Hexagon bolt M8x12 FZB
2	2	11408025	Hexagon bolt M8x25 FZB
3	1	422560	Frame part 12
4	1	422668	Wheel motor assembly
5	1	422670	Hydraulic tank assembly
6	1	422682	First base assembly
7	2	423601	Hose clamp
8	1	477404	Hydraulic hose 1. 3/4"x 825mm
9	1	477406	Hydraulic hose 2.1/2" x 500mm
10	1	477408	Hydraulic hose 3.1/2"x 1780mm
11	1	477410	Hydraulic hose 4. 1/2"x 460mm
12	1	477412	Hydraulic hose 5.1/2" x 1420mm
13	1	477414	Hydraulic hose 6.3/8"x2200mm
14	1	477416	Hydraulic hose 7.3/8"x 2690mm
15	1	477418	Hydraulic hose 8.3/8" x1625mm
16	1	477420	Hydraulic hose 9.3/8" x1820mm
17	5	82108000	Washer M8 FZB

Break all edges

The documents are confidential and must not be accounted for copied or disclosed to any third person. HEDENSTED GRUPPEN A/S		Scale:	Not specified tolerance according to:	Sheet size:	
		1 : 8		A3	
	Part No.: 422684		Material:	Surface properties:	Sheet:
					1 / 2
Description 1: Second base assembly					
Description 2:					

Revision:	Approved	Date:	Revision Description
1	HG	28-09-2015	Revision changed to numeric

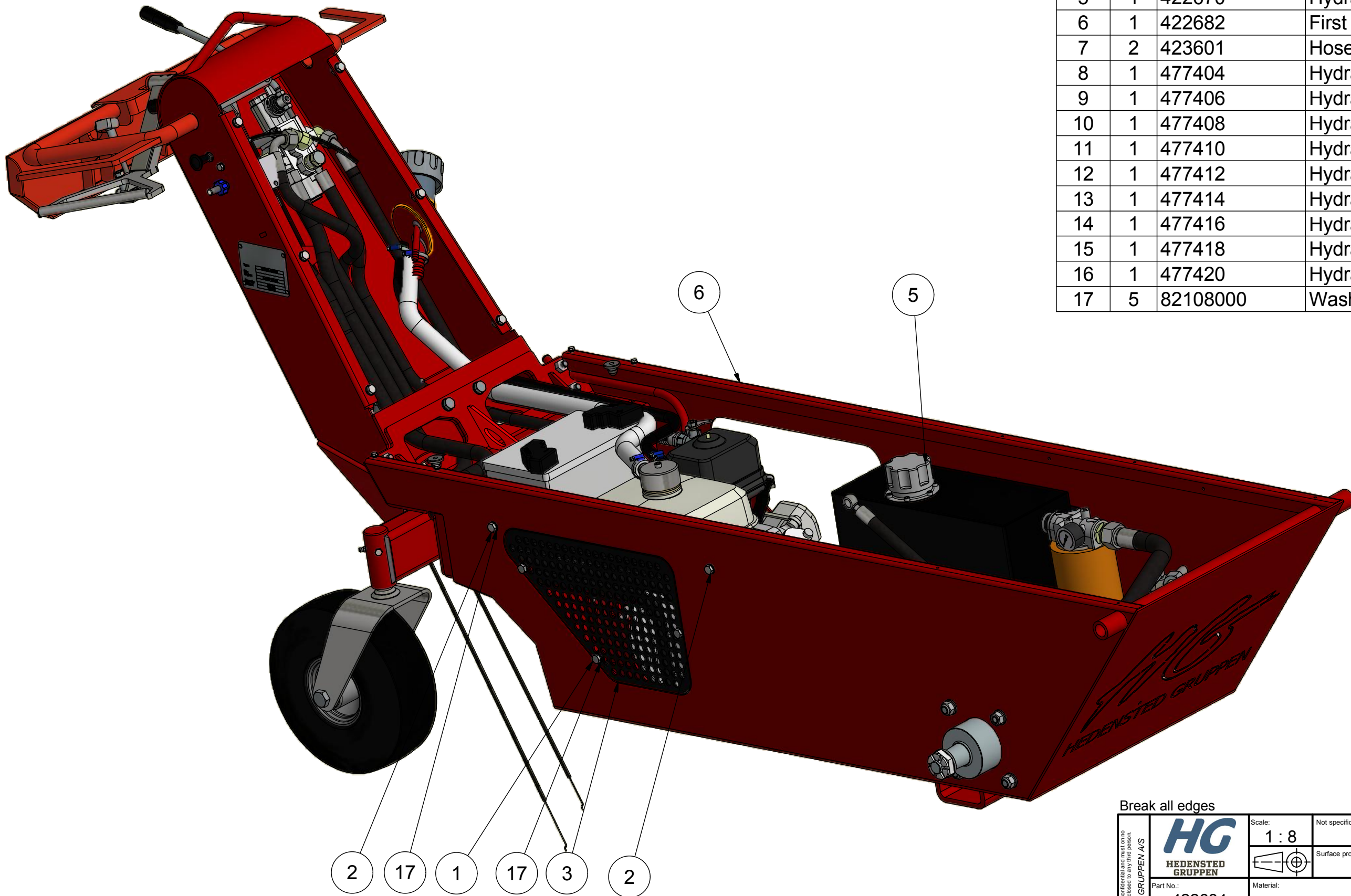

Parts List

ITEM	QTY	PART NUMBER	DESCRIPTION
1	3	11408012	Hexagon bolt M8x12 FZB
2	2	11408025	Hexagon bolt M8x25 FZB
3	1	422560	Frame part 12
4	1	422668	Wheel motor assembly
5	1	422670	Hydraulic tank assembly
6	1	422682	First base assembly
7	2	423601	Hose clamp
8	1	477404	Hydraulic hose 1. 3/4"x 825mm
9	1	477406	Hydraulic hose 2. 1/2" x 500mm
10	1	477408	Hydraulic hose 3. 1/2"x 1780mm
11	1	477410	Hydraulic hose 4. 1/2"x 460mm
12	1	477412	Hydraulic hose 5. 1/2" x 1420mm
13	1	477414	Hydraulic hose 6. 3/8"x2200mm
14	1	477416	Hydraulic hose 7. 3/8"x 2690mm
15	1	477418	Hydraulic hose 8. 3/8" x1625mm
16	1	477420	Hydraulic hose 9. 3/8" x1820mm
17	5	82108000	Washer M8 FZB

Break all edges

The documents are strictly confidential and must not be accounted for copied or disclosed to any third person. HEDENSTED GRUPPEN A/S	 HEDENSTED GRUPPEN	Scale: 1:8	Not specified tolerance according to:	Sheet size: A3
	Part No.: 422684	Material:	Surface properties:	Sheet: 2/2
	Description 1: Second base assembly			
	Description 2:			

Revision:	Approved	Date:	Revision Description
1	HG	28-09-2015	Revision changed to numeric

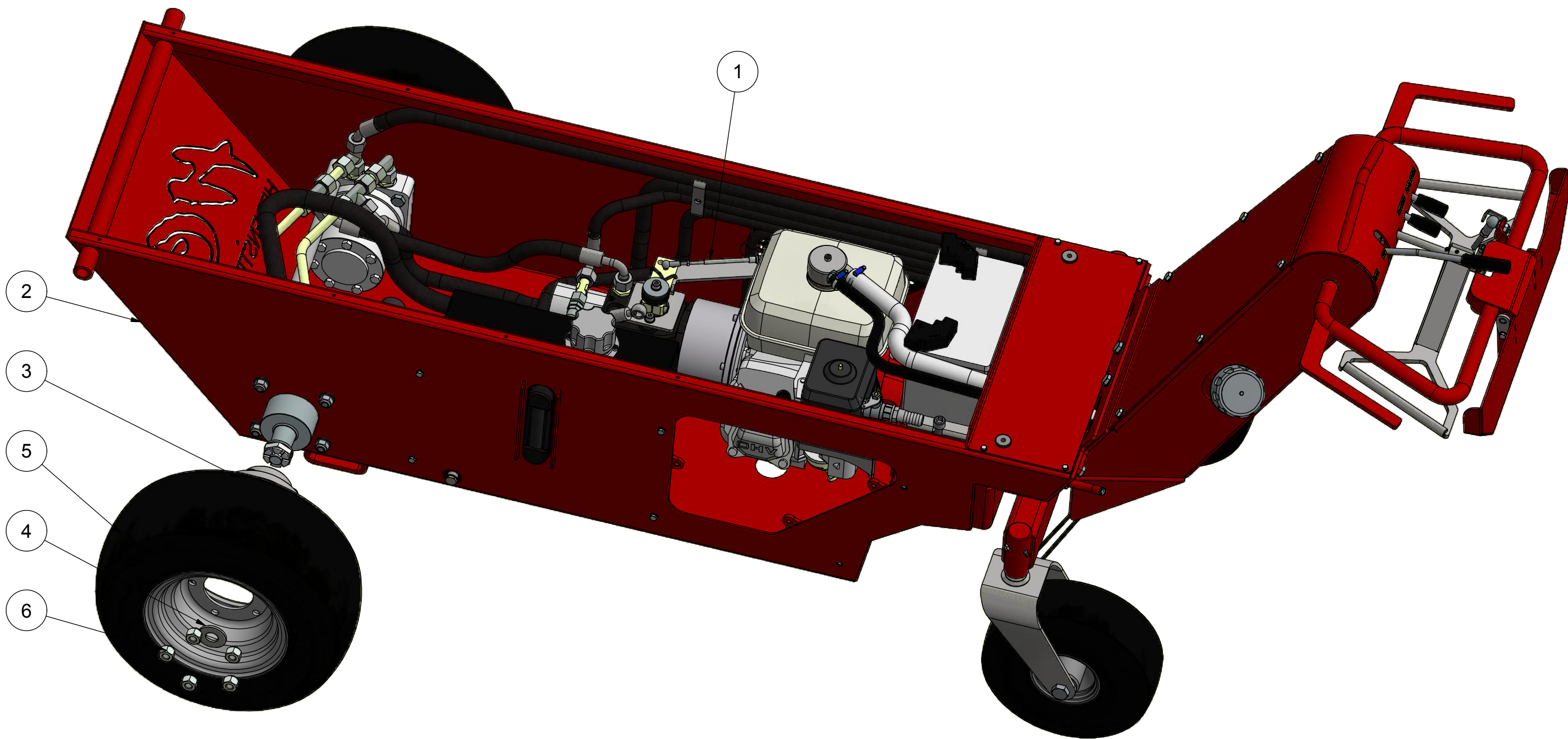

Parts List

ITEM	QTY	PART NUMBER	DESCRIPTION
1	1	422632	Sterring cable for Hydra combi
2	1	422684	Second base assembly
3	2	423471	Wheel hub for omrw
4	2	423545	Washer f/OMRW 45x20,5x4 FZB
5	2	474733	Wheel F. LP190-8/8 Hf400 silve
6	10	479910	Wheel nut M12x1,5 NV22 60`FZB
Revision:	Approved	Date:	Revision Description
1	HG	28-09-2015	Revision changed to numeric

Break all edges

<small>The documents strictly confidential and must not be accounted by copied or disclosed to any third person.</small> HEDENSTED GRUPPEN A/S		Scale: 1 : 6	Not specified tolerance according to: DS/ISO 2768-m	Sheet size: A3
	Part No.: 422686	Surface properties:		Sheet: 1 / 1
Description 1: Third base assembly				
Description 2:				

Parts List			
ITEM	QTY	PART NUMBER	DESCRIPTION
1	1	10508050	Stop screw M8x50-B
2	2	11406016	Hexagon bolt M6x16 FZB
3	1	11406020	Hexagon bolt M6x20 FZB
4	6	11408016	Hexagon bolt M8x16 FZB
5	1	11408035	Hexagon bolt M8x35 FZB
6	8	11410030	Hexagon bolt M10x30 FZB
7	2	1508000	Nut M8 FZB
8	2	17906000	Self-locking nut M6 FZB
9	3	17908000	Self-locking nut M8 FZB
10	1	30039	Id plate CE for Hydra Combi
11	2	415042	Ball angle joint AS13 M8
12	1	422566	Frame assembly 2
13	1	422640	Trotle cable for Hydra combi
14	1	422642	Choke cable for Hydra combi
15	1	422663	Tilt valve assambly 2014
16	1	422664	Assembly bearing for handle
17	1	422666	Throttle/choke assembly
18	3	423423	Slide bushing Ø12xØ14x7
19	3	423424	Handle, Ø21 cylindrical knob Ø10
20	1	423432	F-Bracket for cable G5x20
21	1	423443	Clips for F-joint
22	1	423464	Sticker for key start
23	1	423570	Alu valveblock pipe mounted
24	1	423572	Valve, cartridge 12v DC 2 way with override
25	1	423590	Bracket for valve
26	1	441720	Key start GX 200
27	1	445091	Fuel tank cap G400
28	1	470565	Choke cable SS-SM
29	1	477117	Straight connector w. gasket Ø15L x 3/8"
30	1	477146	Elbow 3/8"t x Ø15L
31	4	7003208	Blind rivet Ø3.2x8 (4-5,5)
32	4	82106000	Washer M6 FZB
33	6	82108000	Washer M8 FZB
34	8	82110000	Washer M10 FZB
35	1	82606000	Washer Ø6,4x18x1,6 FZB
36	2	89505022	Pin slotted Ø5x22
37	1	M100499	Trottel grip
38	1	M100501	Lock rod assembly
39	1	M100503	Bumper assembly
40	2	M100507	Ball lock
41	1	M100772	Trotle shaft for hydra combi

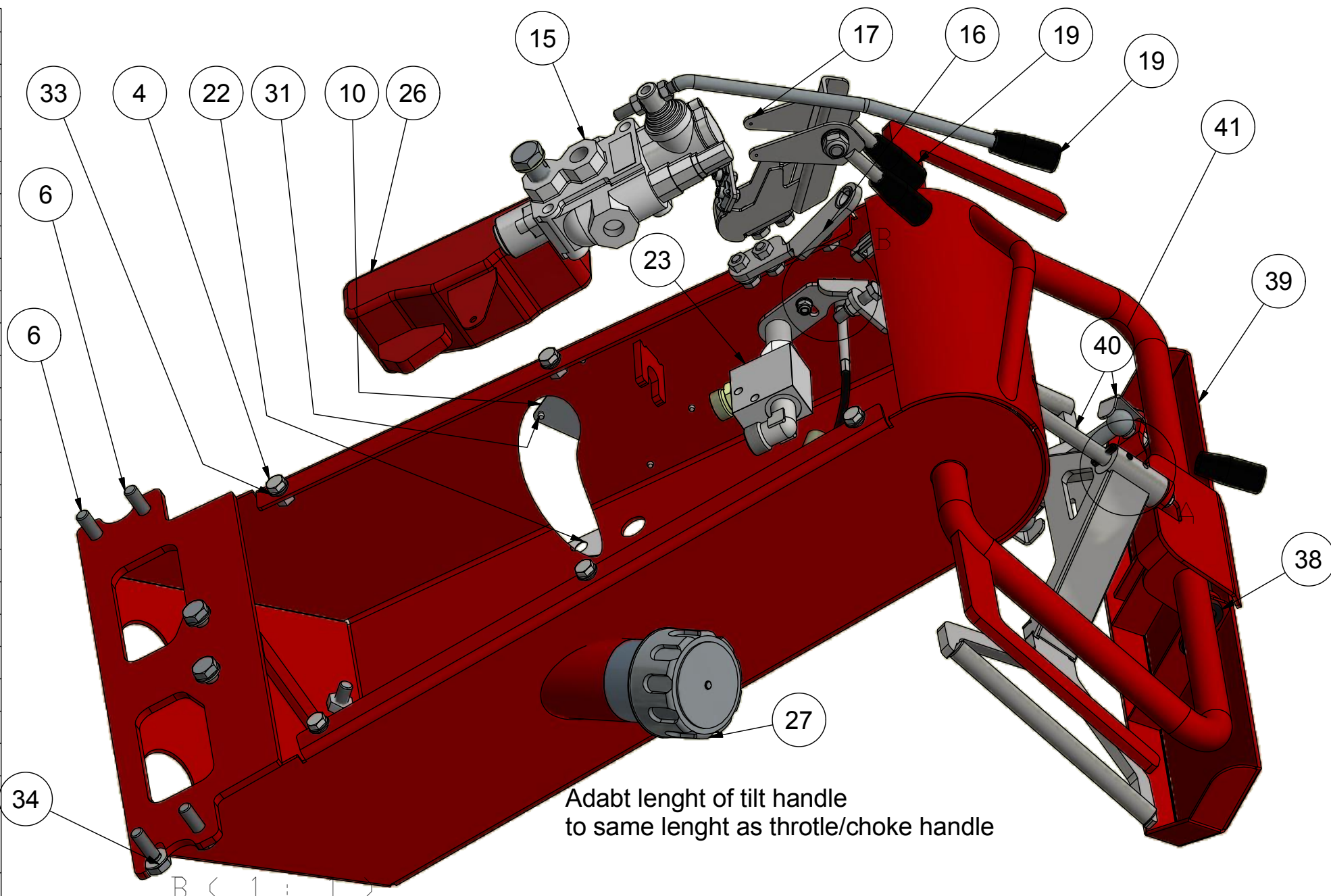

Adabt lenght of tilt handle to same lenght as throttle/choke handle

B < 1 : 1 >

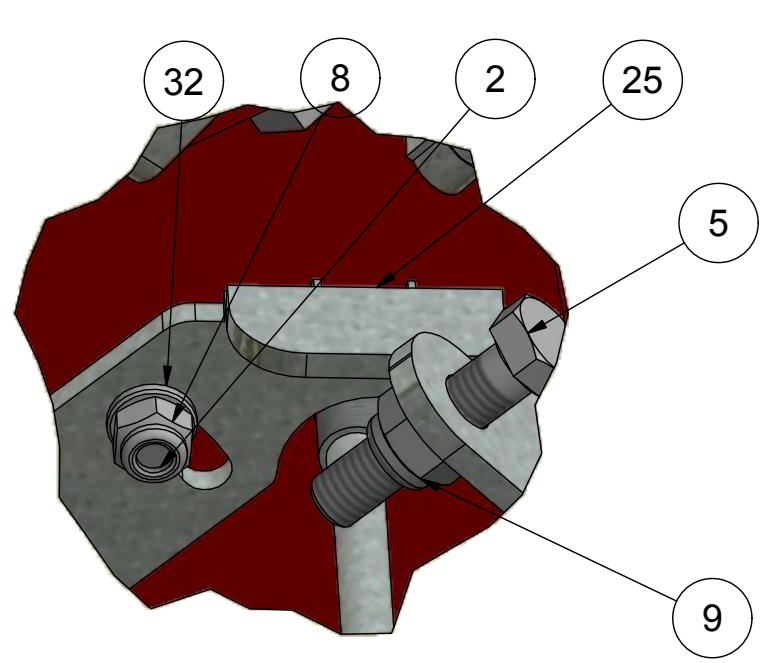

A < 1 : 1,5 >

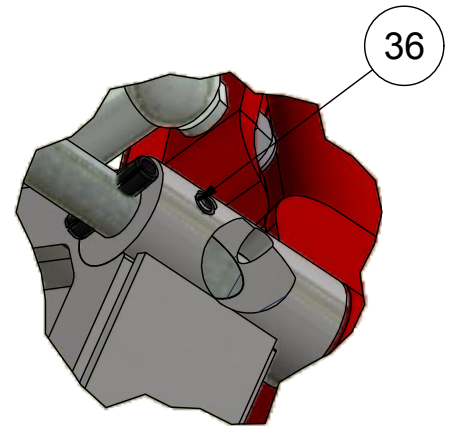

Break all edges

<small>The documents strictly confidential and must not be account be copied or disclosed to any third person.</small> HEDENSTED GRUPPEN A/S	HG	Scale: 1 : 3,7	Not specified tolerance according to:	Sheet size: A3
	HEDENSTED GRUPPEN		Surface properties:	Sheet: 1 / 2
	Part No.: 422678	Material:		
	Description 1: Operator assembly			
Description 2:				

Revision:	Approved	Date:	Revision Description
1	HG	28-09-2015	Revision changed to numeric

D < 1 : 1,5 >

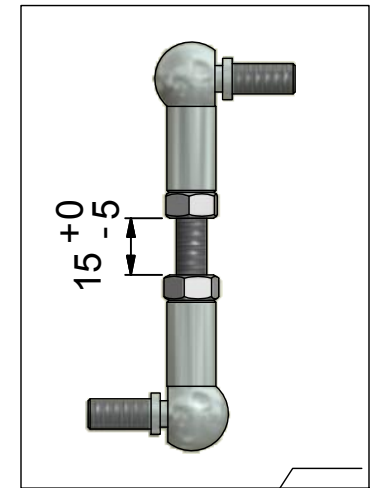
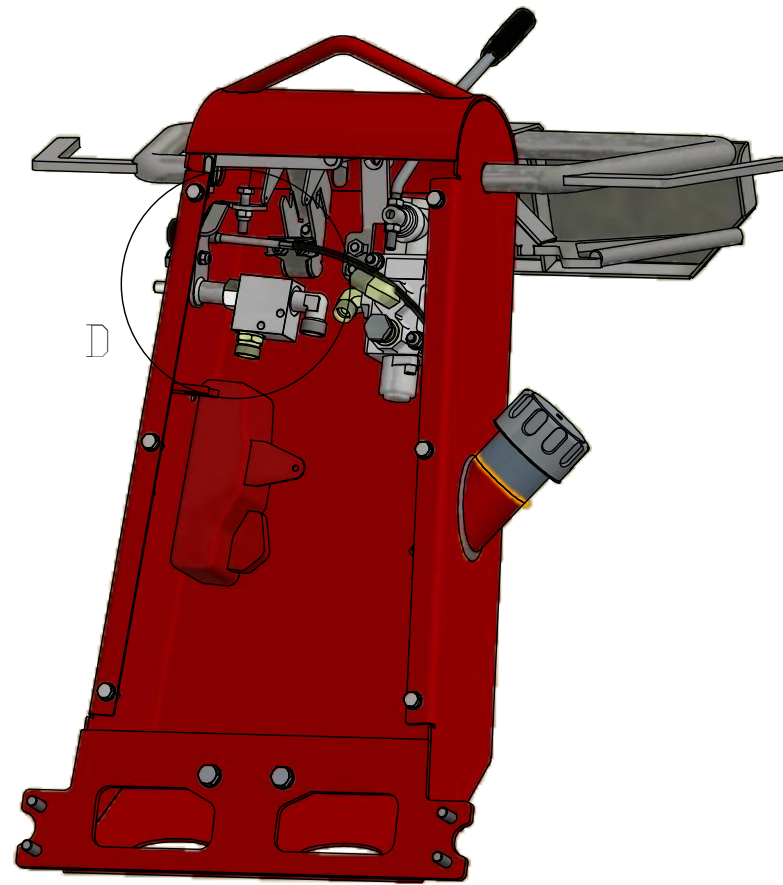
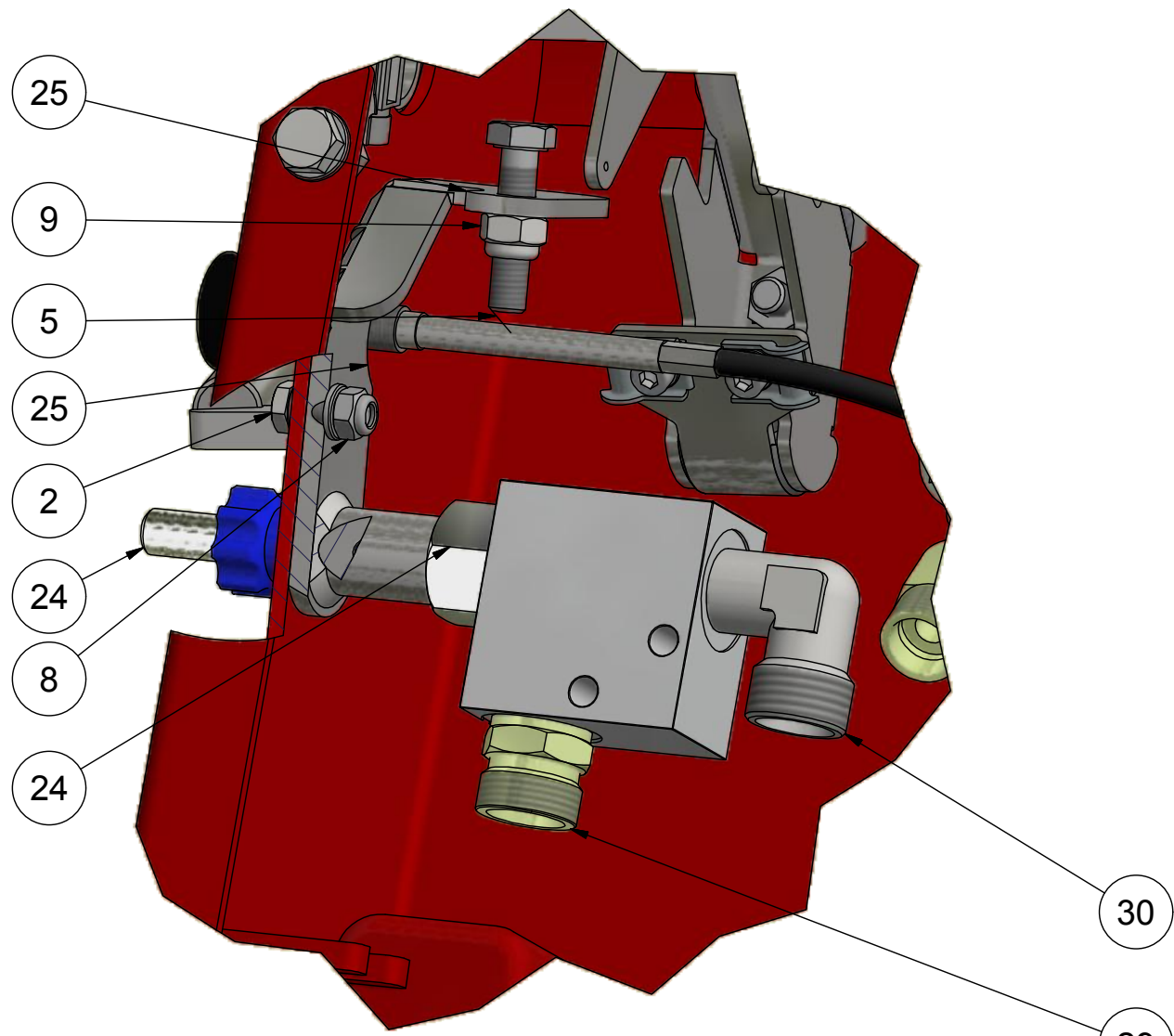

H < 1 : 1,5 >

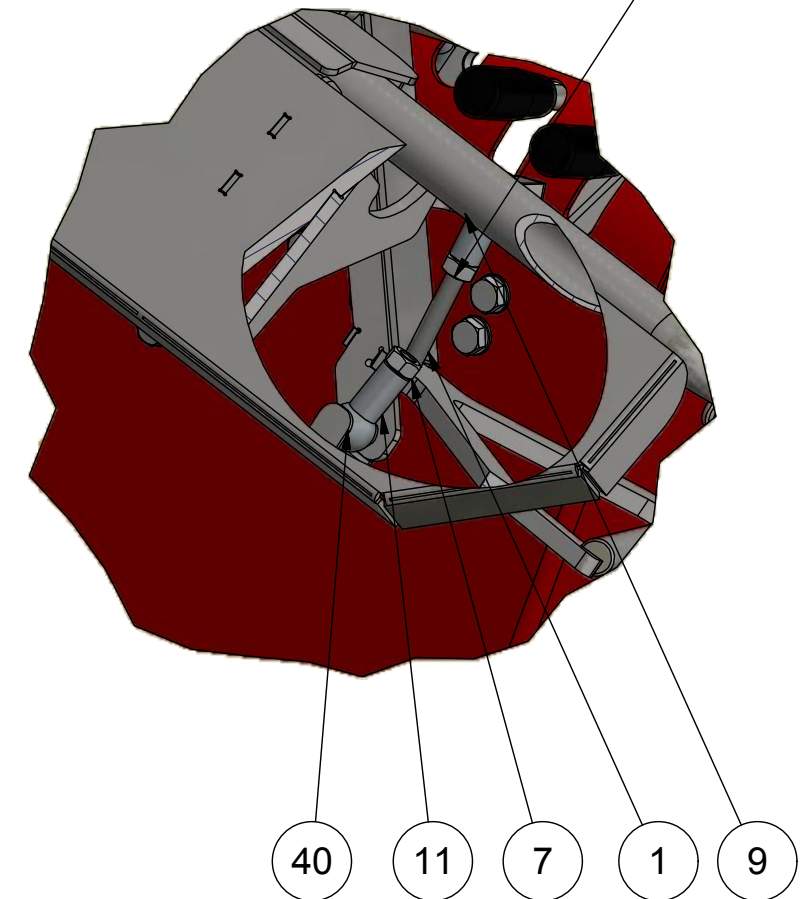
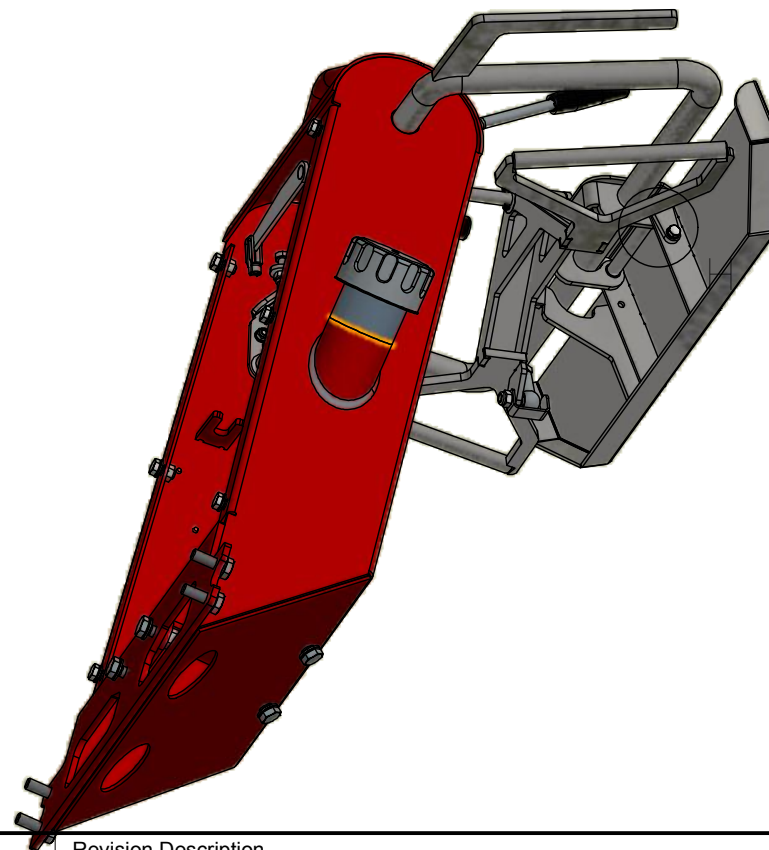
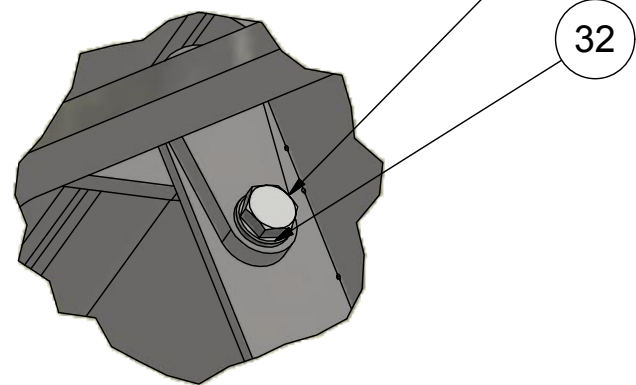

Revision:	Approved	Date:	Revision Description
1	HG	28-09-2015	Revision changed to numeric

Break all edges

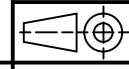
The document is strictly confidential and must not be accounted for copied or disclosed to any third person. HEDENSTED GRUPPEN A/S	 HEDENSTED GRUPPEN	Scale: 1 : 3,7	Not specified tolerance according to:	Sheet size: A3
	Part No.: 422678	Material:	 Surface properties:	Sheet: 2 / 2
Description 1: Operator assembly				
Description 2:				

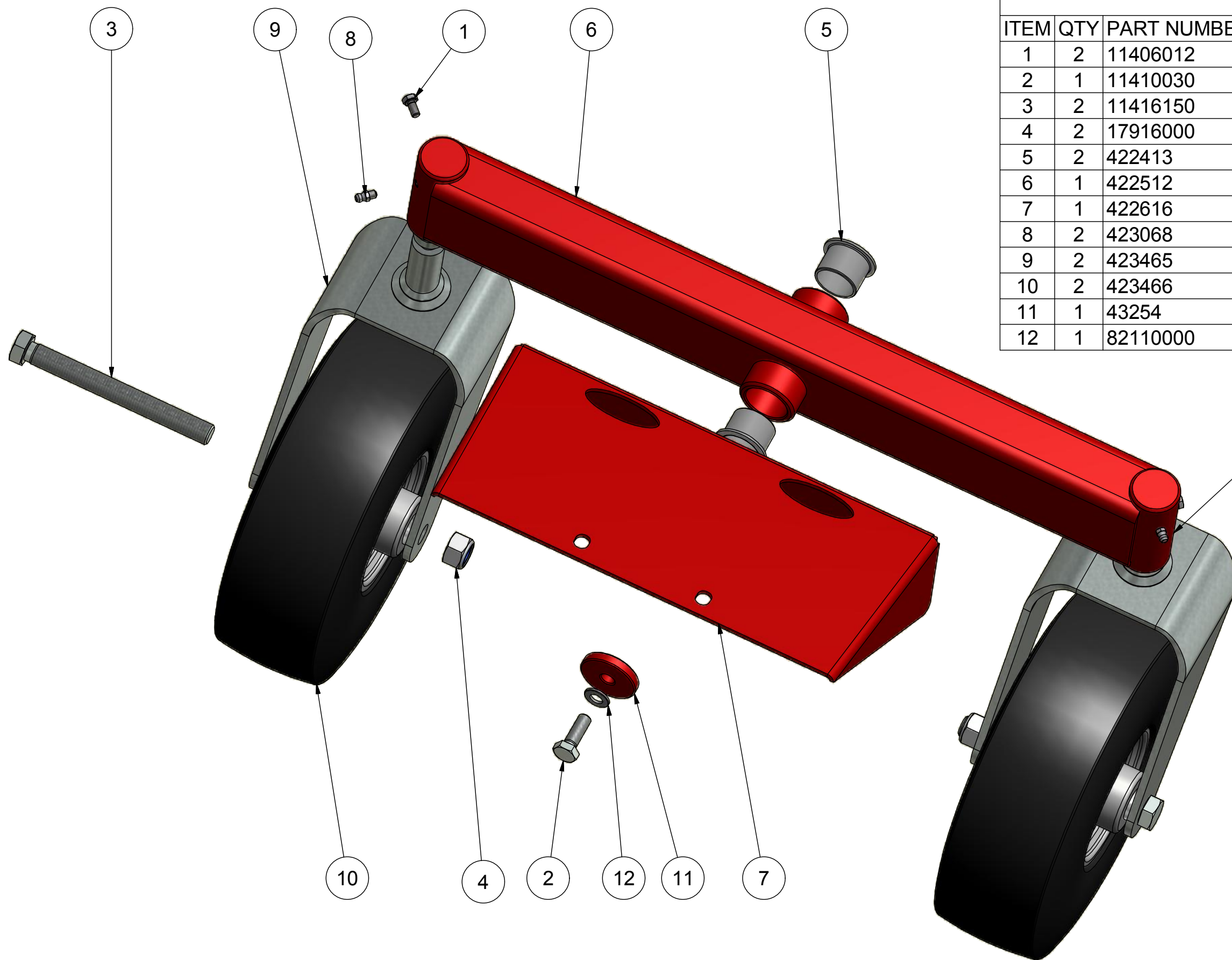

Parts List			
ITEM	QTY	PART NUMBER	DESCRIPTION
1	2	11406012	Hexagon bolt M6x12 FZB
2	1	11410030	Hexagon bolt M10x30 FZB
3	2	11416150	Hexagon bolt M16x150 FZB
4	2	17916000	Self-locking nut M16 FZB
5	2	422413	Slide Bearing PAF-30260 (34x30x26)
6	1	422512	Suspension movable part
7	1	422616	Reinforcement for control
8	2	423068	Grease fitting M6 straight
9	2	423465	Fork for wheel DGT 12"
10	2	423466	Fork wheel SS Hydra
11	1	43254	End plate Ø45
12	1	82110000	Chamfered Washer M10 FZB

Add grease in both grease fittings

Break all edges

The documents strictly confidential and must not be accounted by copied or disclosed to any third person. HEDENSTED GRUPPEN A/S	 HEDENSTED GRUPPEN	Scale:	Not specified tolerance according to:	Sheet size:
		1 : 3	DS/ISO 2768-m	A3
Part No.:		Surface properties:		Sheet:
422680				1 / 1
Description 1:	Suspension assembly			
Description 2:				

Revision:	Approved	Date:	Revision Description
1	HG	28-09-2015	Revision changed to numeric

Parts List			
ITEM	QTY	PART NUMBER	DESCRIPTION
1	6	11405012	Hexagon bolt M5x12 FZB
2	2	11406012	Hexagon bolt M6x12 FZB
3	1	11406025	Hexagon bolt M6x25 FZB
4	4	11406085	Hexagon bolt M6x85 FZB
5	1	11408020	Hexagon bolt M8x20 FZB
6	4	11408025	Hexagon bolt M8x25 FZB
7	2	11412055	Hexagon bolt M12x55 FZB
8	3	1508000	Nut M8 FZB
9	1	422506	Filter box main assembly
10	1	422572	Exhaust system for killing box
11	1,25 m	422636	Heat hose 1"
12	1	422638	Killing box
13	3	423439	HG Logo - size 75 x110mm

Parts List			
ITEM	QTY	PART NUMBER	DESCRIPTION
14	1	470565	Choke cable SS-SM
15	2	474008	Hose clamp 22-30
16	4	474010	Hose clamp 25-35
17	0,6 m	477572	Alfasteel hose Ø20
18	2	4809335	Washer SRKB Ø9x35x3 FZB
19	6	82105900	Washer M5 FZB
20	6	82106000	Washer M6 FZB
21	5	82108000	Washer M8 FZB
22	2	82112000	Washer M12 FZB
23	1	M100826	Heat plate
24	1	M102628	Filter cover
25	1	M12417	Insulation 70x1200x300

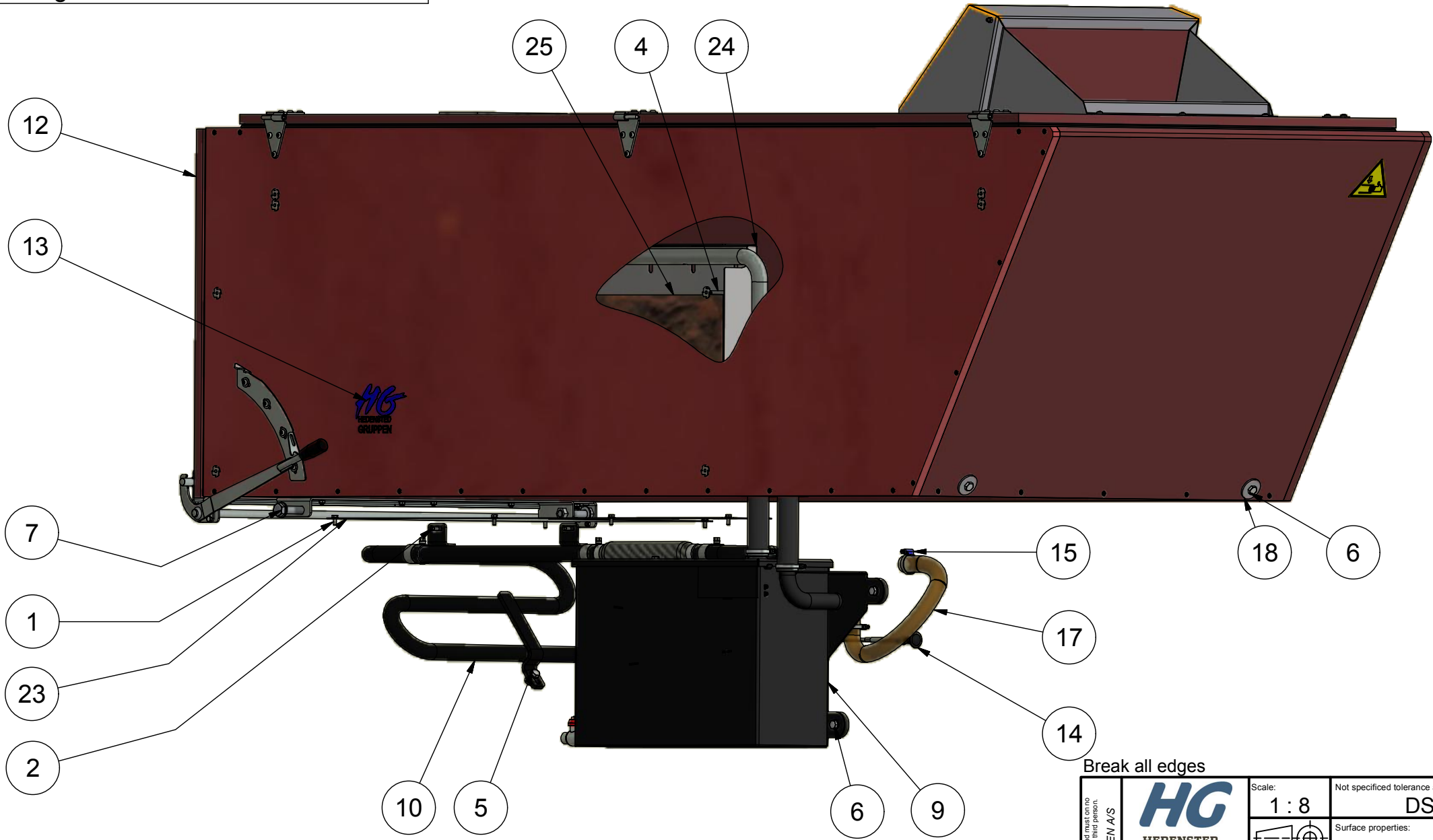

Break all edges

Revision:	Approved	Date:	Revision Description
1	KC	25-04-2017	Part List updated

The documents strictly confidential and must not be accounted for copied or disclosed to any third person. HEDENSTED GRUPPEN A/S	 HEDENSTED GRUPPEN	Scale: 1 : 8	Not specified tolerance according to: DS/ISO 2768-m	Sheet size: A3
	Part No.: 280150	Material:	Surface properties:	Sheet: 1 / 2
Description 1:		Killing box 120 males		
Description 2:		For Hydra Combi		

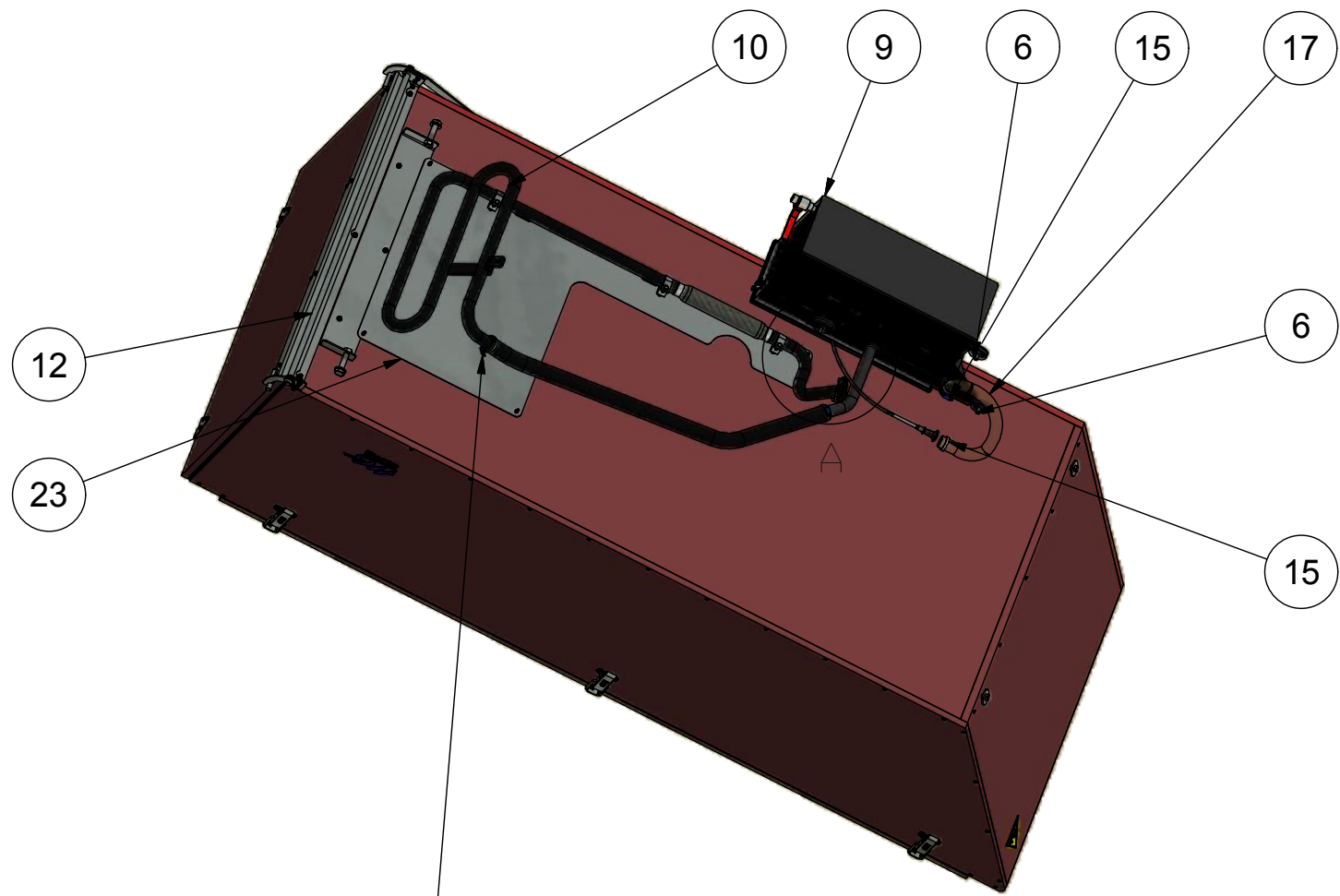

A < 1 : 4 >

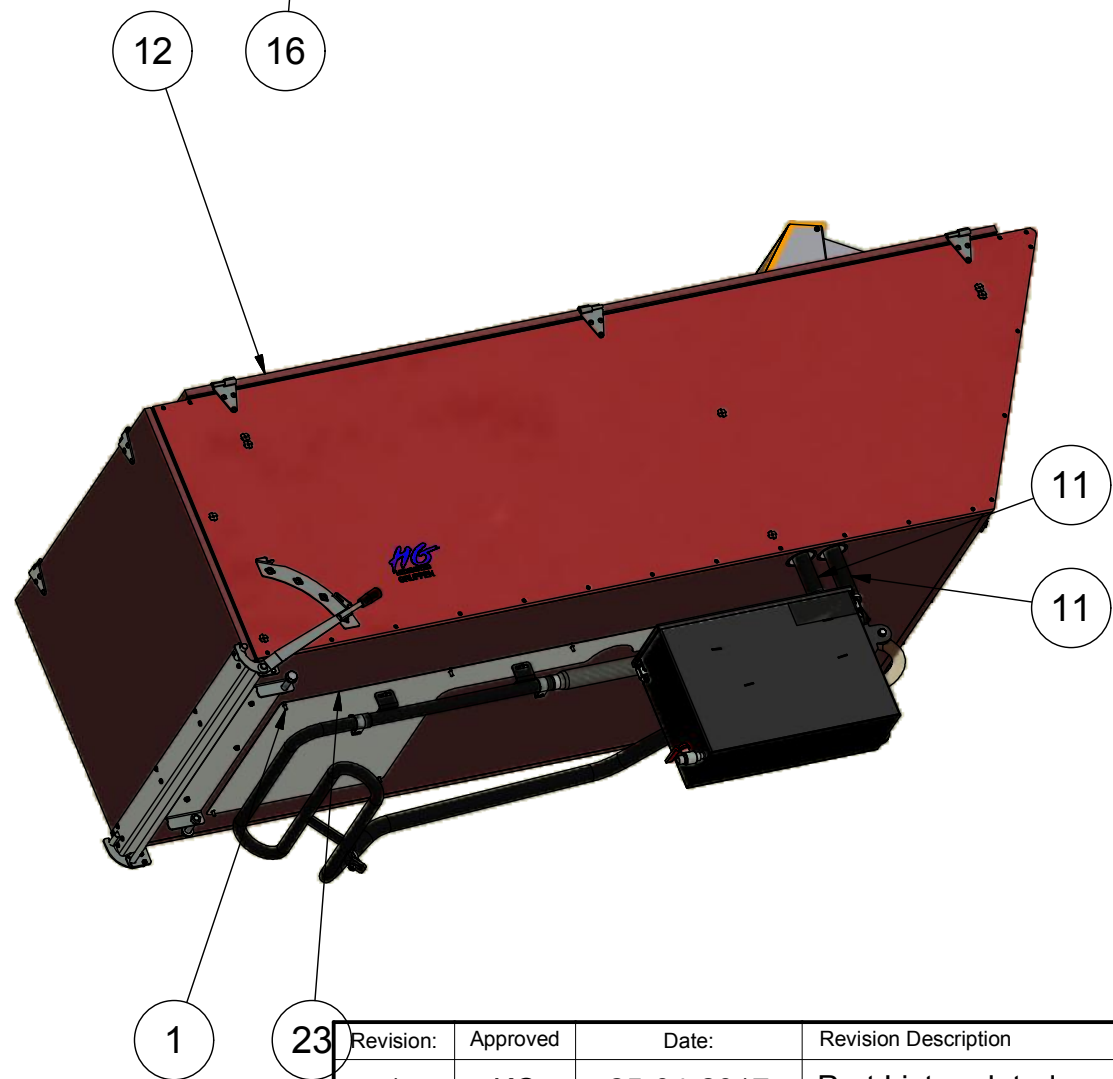
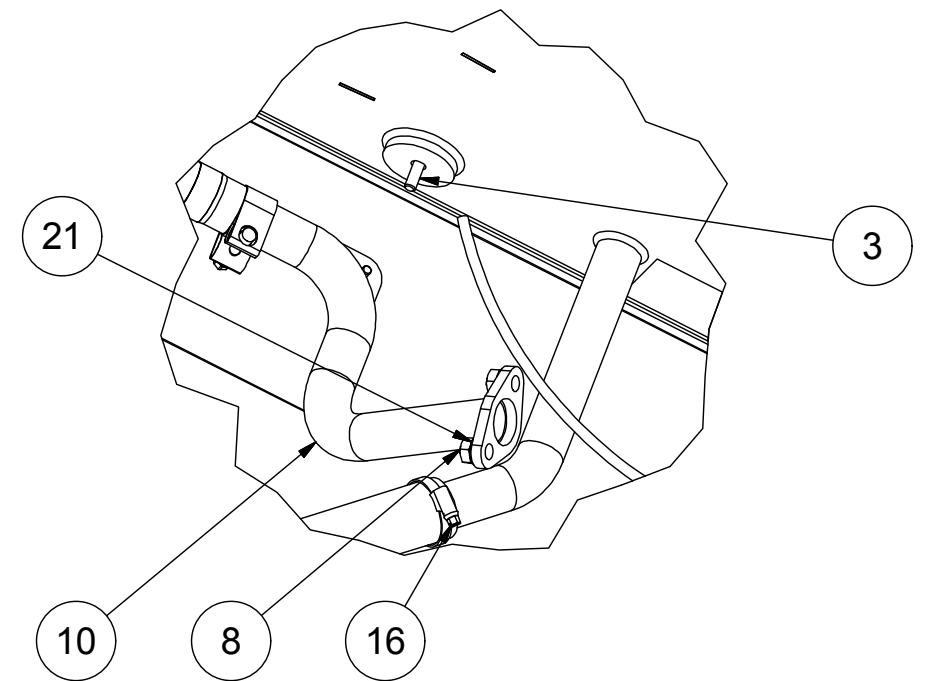

Break all edges

The documents are strictly confidential and must not be accounted for copied or disclosed to any third person. HEDENSTED GRUPPEN A/S	 HEDENSTED GRUPPEN	Scale: 1 : 8	Not specified tolerance according to: DS/ISO 2768-m	Sheet size: A3	
	Part No.: 280150	Surface properties:			
	Material:				Sheet: 2 / 2
	Description 1: Killing box 120 males				
Description 2: For Hydra Combi					

Revision:	Approved	Date:	Revision Description
1	KC	25-04-2017	Part List updated

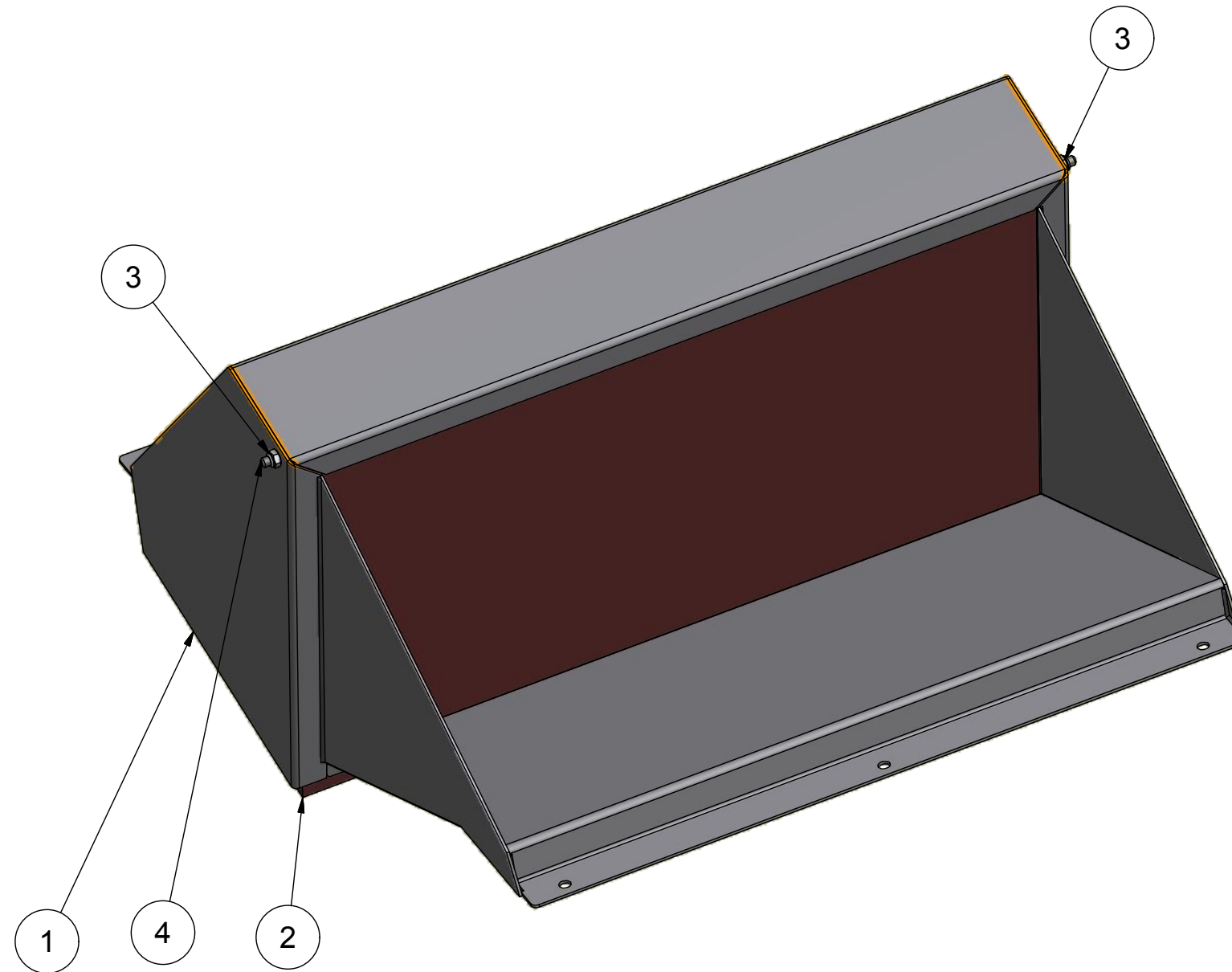

Parts List

ITEM	QTY	PART NUMBER	DESCRIPTION
1	1	422590	Mail box assembly 1
2	1	422592	Mail box assembly 2
4	1	422588	Thread rod for mail box
3	2	17905000	Self-locking nut M5 FZB 1

Revision:	Approved	Date:	Revision Description
1	HG	28-09-2015	Revision changed to numeric

Break all edges

<small>The document is strictly confidential and must not be disclosed to any third person.</small> HEDENSTED GRUPPEN A/S	 HEDENSTED GRUPPEN	Scale: 1 : 3	Not specified tolerance according to: DS/ISO 2768-m	Sheet size: A3
	Part No.: 280160	Surface properties:		
	Description 1: HG Mail box complete			
	Description 2: HG Killing box			

Parts List			
ITEM	QTY	PART NUMBER	DESCRIPTION
1	4	10203008	Hexagon cylinder head M3x08 FZB
2	2	11406030	Hexagon bolt M6x30 FZB
3	4	17903000	Self-locking nut M3 FZB
4	2	17906000	Self-locking nut M6 FZB
5	1	422508	Filter box assembly 1
6	1	422510	Filter box assembly 2
7	1	422511	Polyester filter PPI20
8	2	422554	Mini Latch
9	1	422644	Gasket for filterbox
10	1	477527	1/4" Ball valve male/female
11	2	4809335	Washer type SRKB ø9x35x3
12	4	82103000	Chamfered Washer M3 FZB

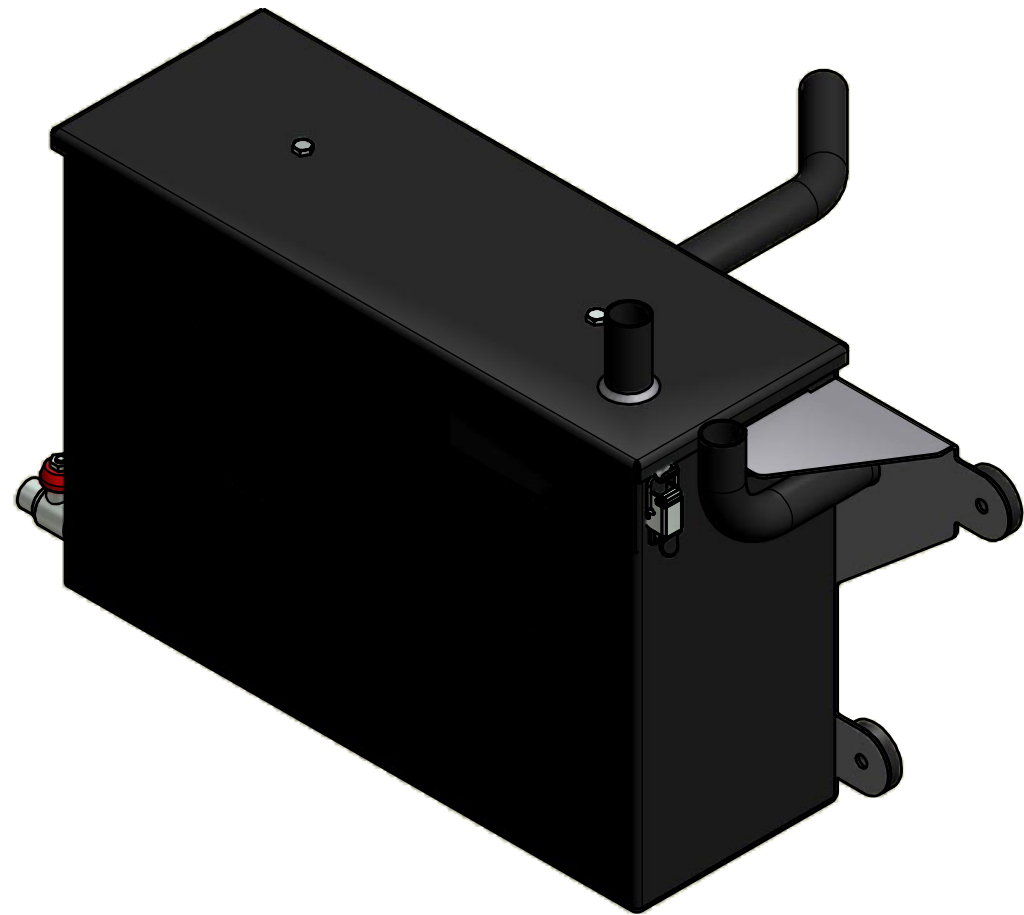

Glue gasket to lid with scilicone

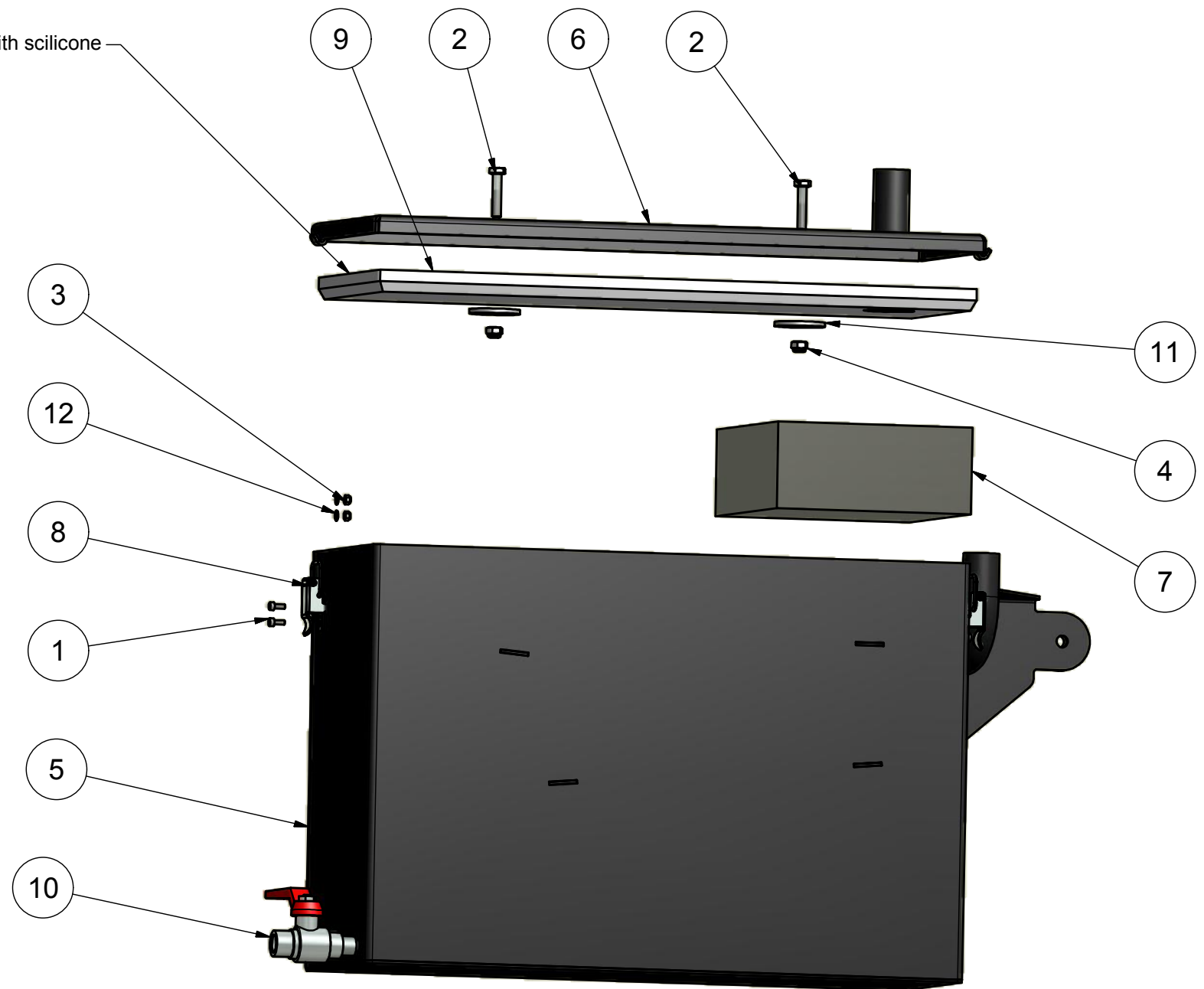

Break all edges

<small>This document is strictly confidential and must not be accounted for copied or disclosed to any third person.</small> HEDENSTED GRUPPEN A/S	 HEDENSTED GRUPPEN	Scale: 1 : 4	Not specified tolerance according to:	Sheet size: A3
	Part No.: 422506	Material:	Surface properties:	Sheet: 1 / 1
Description 1: Filter box main assembly				
Description 2:				



Revision:	Approved	Date:	Revision Description
1	HG	28-09-2015	Revision changed to numeric

Parts List

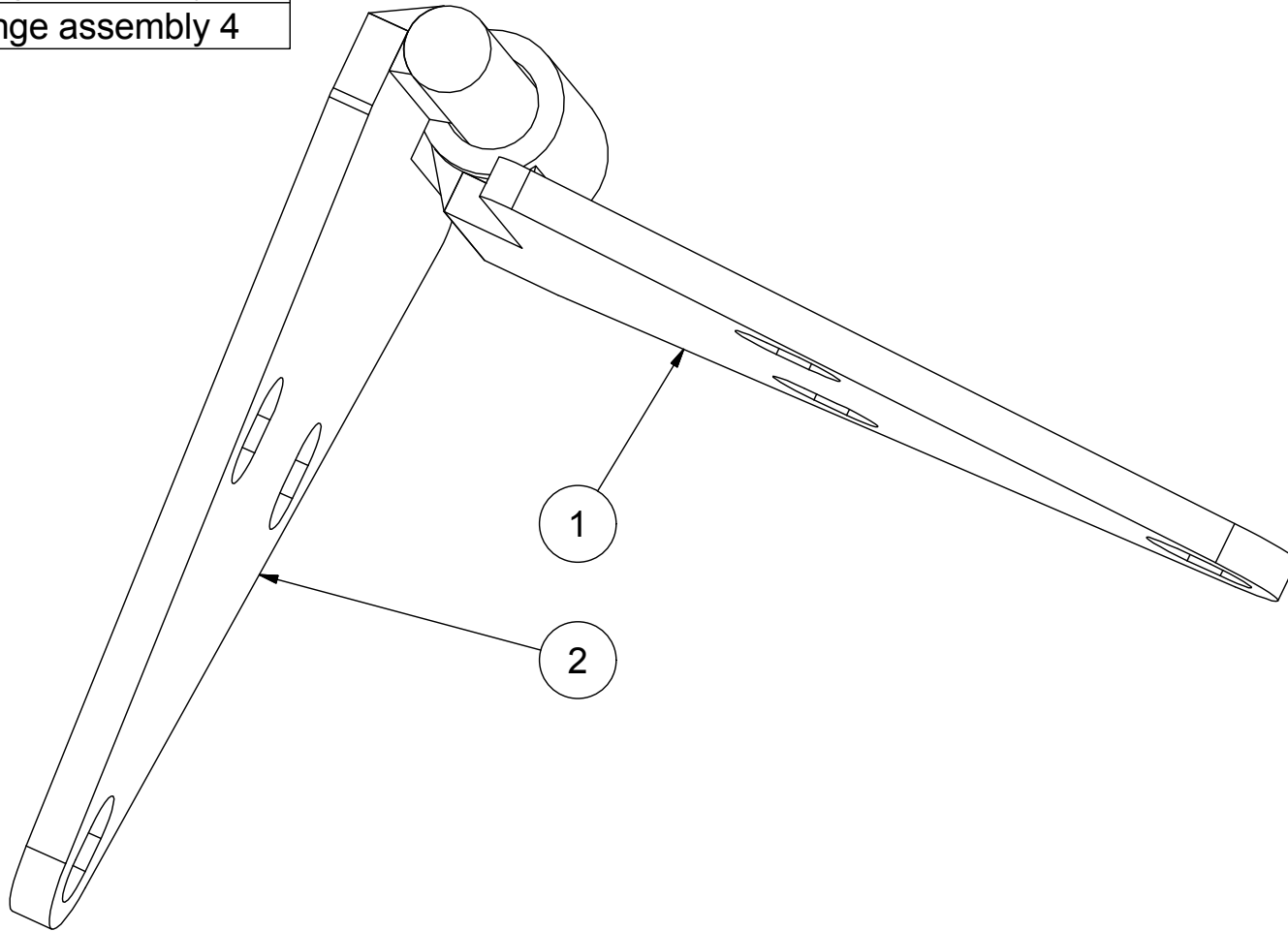
ITEM	QTY	PART NUMBER	DESCRIPTION
1	1	422522	Hinge assembly 1
2	1	422528	Hinge assembly 4



Break all edges

This document is strictly confidential and must not be copied or disclosed to any third person. HEDENSTED GRUPPEN A/S	 HEDENSTED GRUPPEN	Scale: 2 : 1	Not specified tolerance according to: DS/ISO 2768-m	Sheet size: A4
			Surface properties:	Sheet: 1 / 1
	Part No.: 422518	Material:		
	Description 1: Hinge right			
Description 2:				



Revision:	Approved	Date:	Revision Description
1	HG	28-09-2015	Revision changed to numeric

Parts List

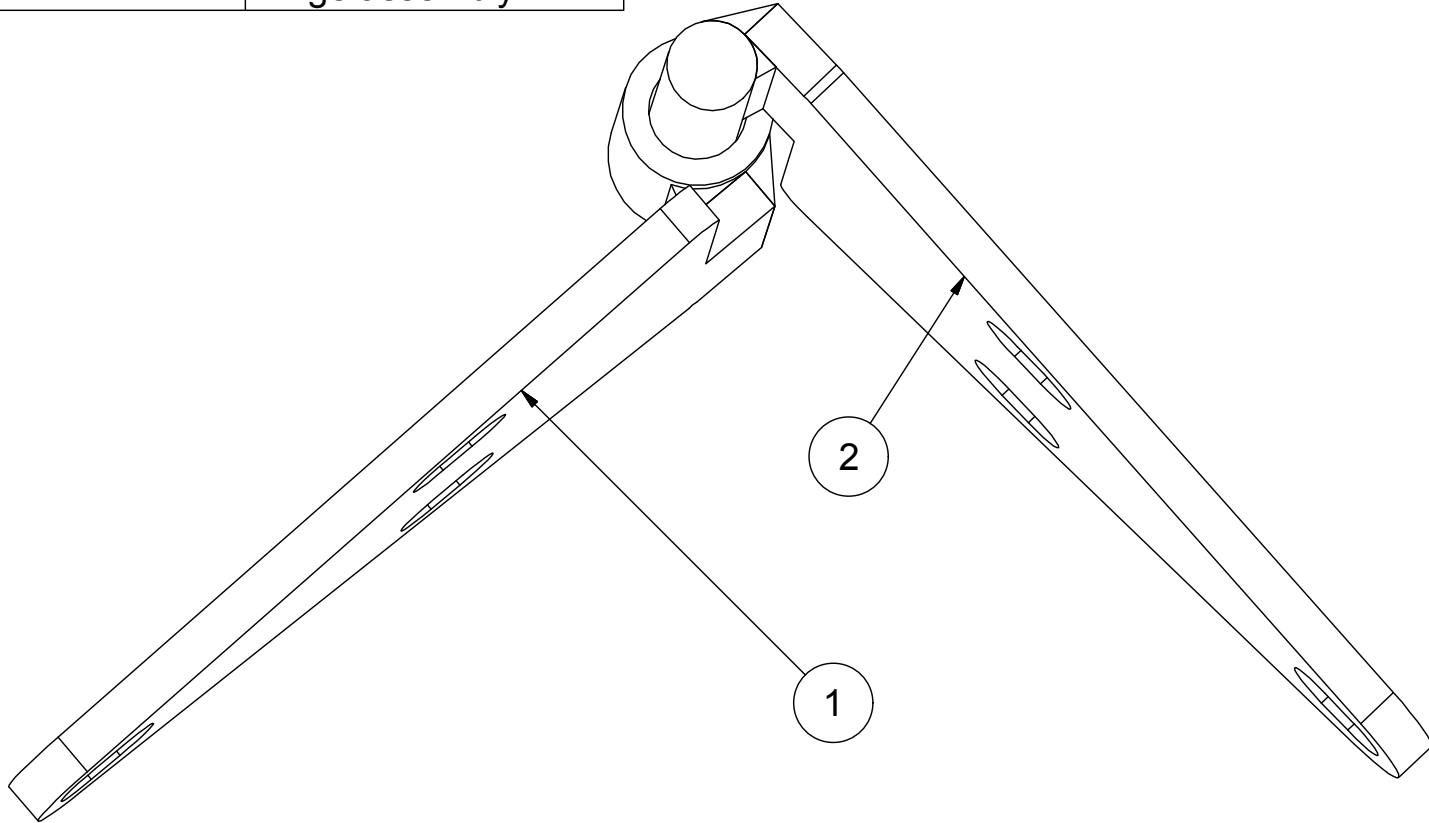
ITEM	QTY	PART NUMBER	DESCRIPTION
1	1	422526	Hinge assembly 3
2	1	422524	Hinge assembly 2



Break all edges

This document is strictly confidential and must not be copied or disclosed to any third person. HEDENSTED GRUPPEN A/S	 HEDENSTED GRUPPEN	Scale: 2 : 1	Not specified tolerance according to: DS/ISO 2768-m	Sheet size: A4
			Surface properties:	Sheet: 1 / 1
	Part No.: 422520	Material:		
	Description 1: Hinge left			
Description 2:				

Revision:	Approved	Date:	Revision Description
1	HG	28-09-2015	Revision changed to numeric

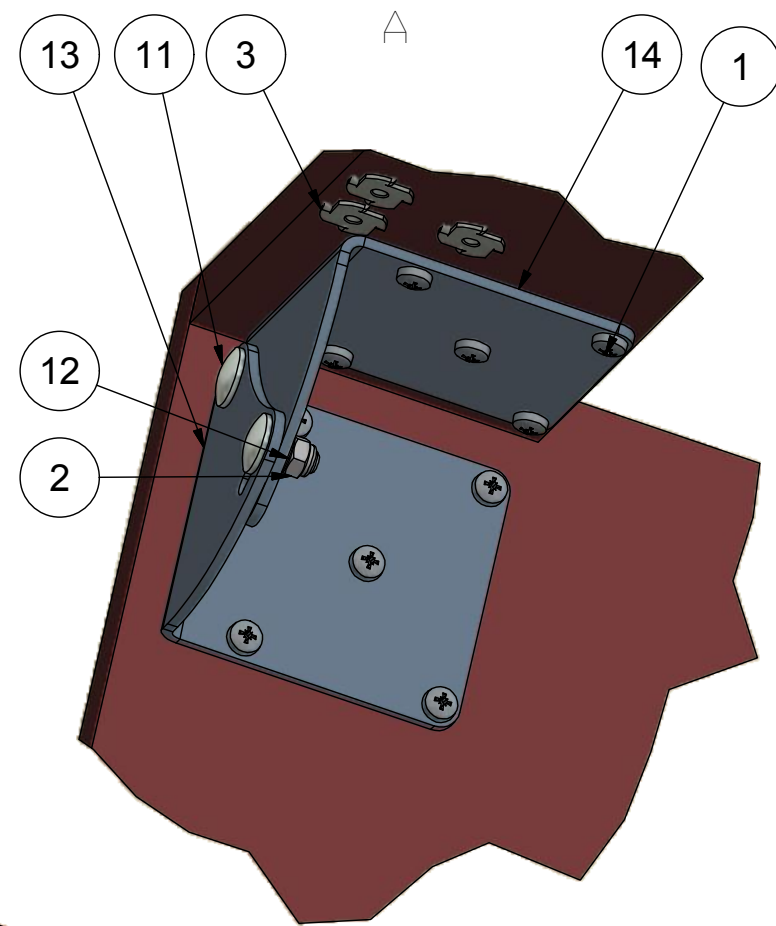

Parts List			
ITEM	QTY	PART NUMBER	DESCRIPTION
1	20	140872	Wood screw pan head 5 x 16
2	4	17906000	Self-locking nut M6 FZB
3	27	19205000	Drive in nut M5 FZB
4	2	19208000	Drive in nut M8 FZB
5	1	41436	Box part 1
6	1	41437	Box part 9
7	1	41438	Box part 2
8	1	41440	Box part 3
9	1	41444	Box part 5
10	1	41445	Box part 8
11	4	64406016	Cup head square neck bolt M6x16 FZB
12	4	82106000	Washer M6 FZB
13	2	M102620	Corner stiffening part 1
14	2	M102621	Corner stiffening part 2
15	45	M202010	Wood screw countersunk head 4 x 40

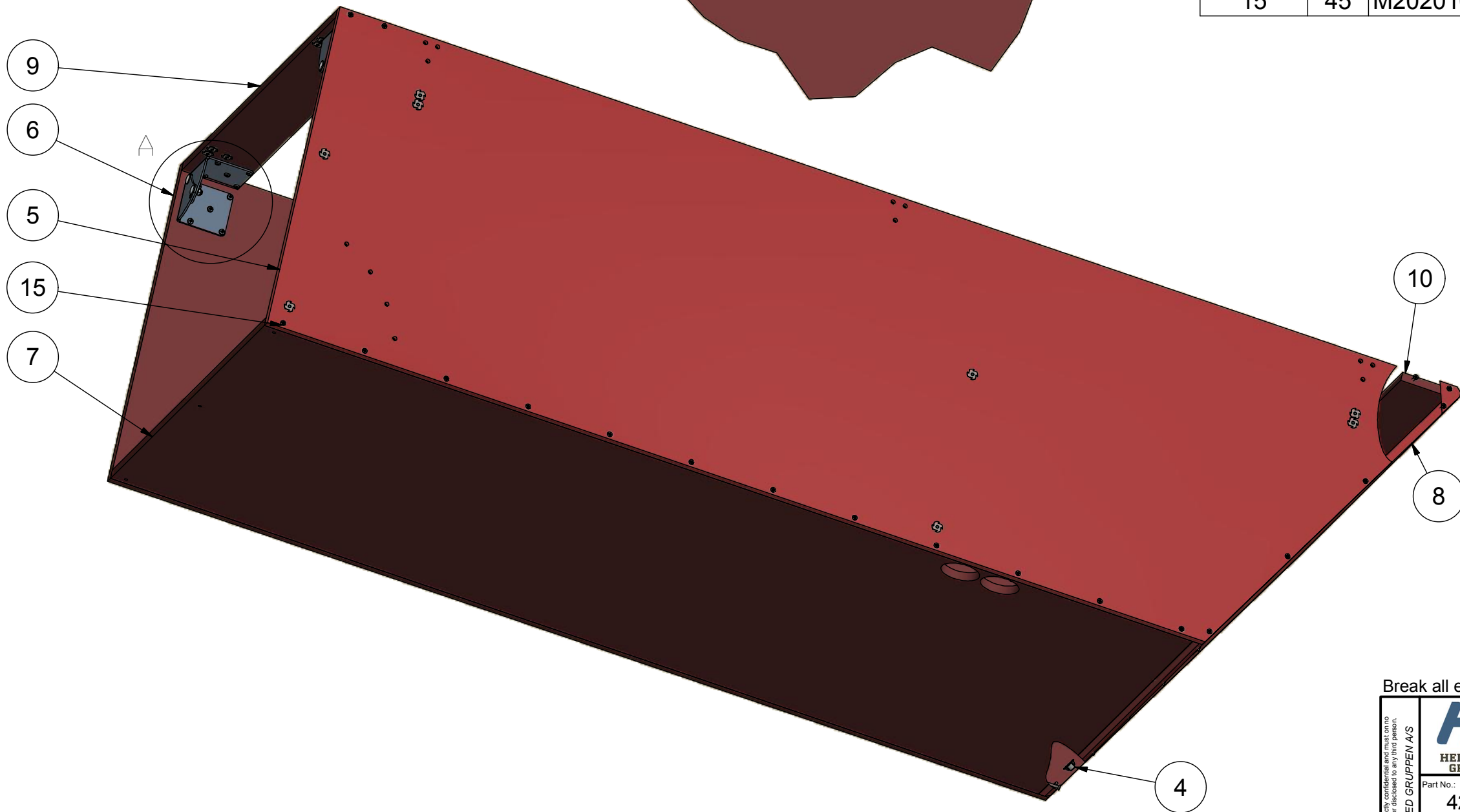

Revision:	Approved	Date:	Revision Description
1	KC	25-04-2017	Part list update

Break all edges

<small>The document is strictly confidential and must not be accounted for copied or disclosed to any third person.</small> HEDENSTED GRUPPEN A/S	 HEDENSTED GRUPPEN	Scale: 1 : 10	Not specified tolerance according to:	Sheet size: A3
	Part No.: 422531	Material:	Surface properties: Edges painted brown	Sheet: 2 / 2
Description 1: Box for killing box				
Description 2:				

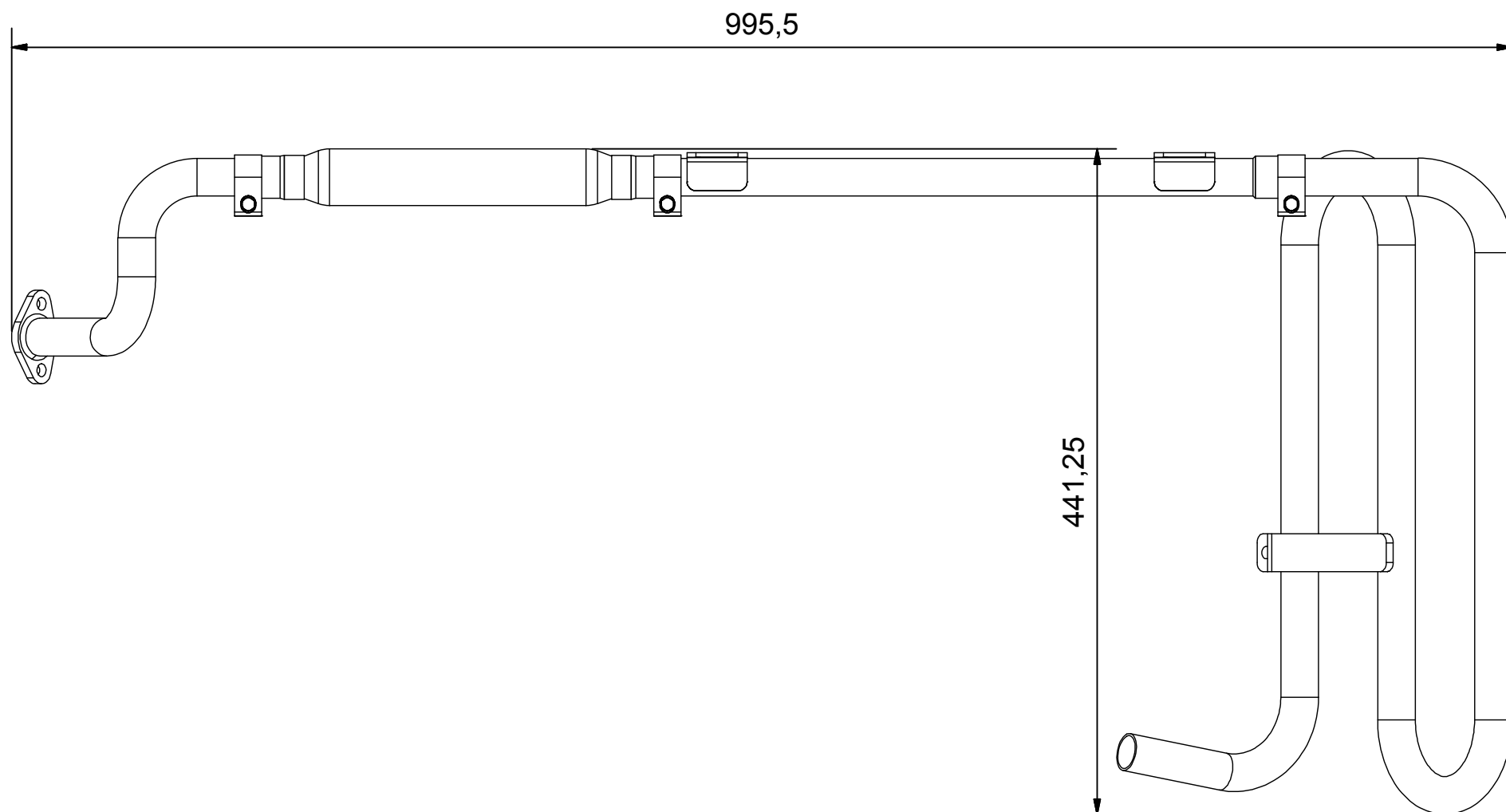
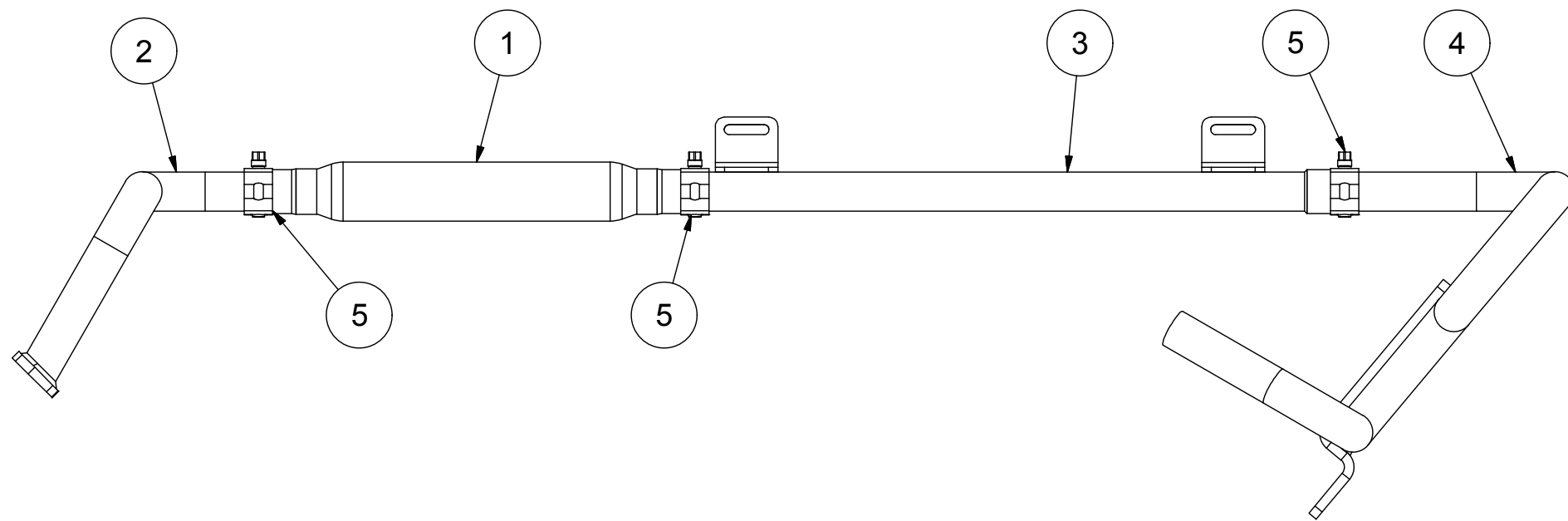
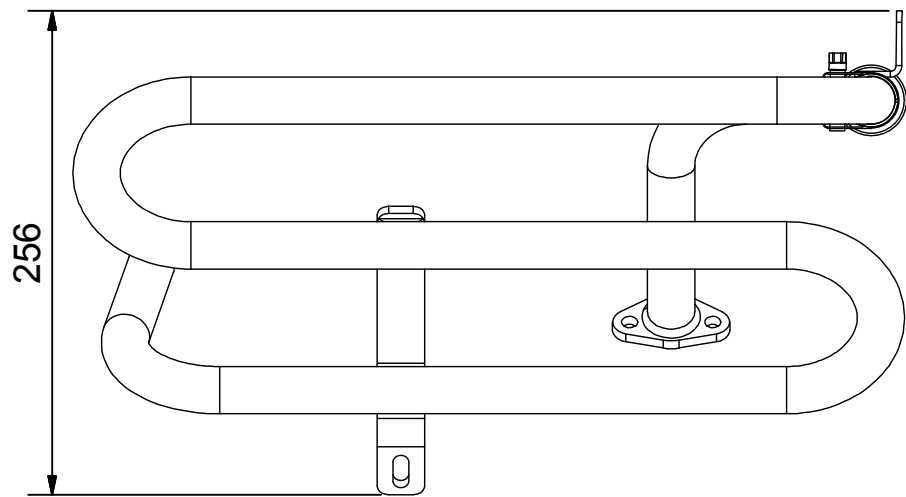

Parts List

ITEM	QTY	PART NUMBER	DESCRIPTION
1	1	422530	Flex pipe for exhaust
2	1	422569	Exhaust assembly 1
3	1	422571	Exhaust assembly 2
4	1	422573	Exhaust assembly 3
5	3	422650	Hose clamp Ø27-Ø29

Revision:	Approved	Date:	Revision Description
1	HG	28-09-2015	Revision changed to numeric

Break all edges

<small>The documents are confidential and must not be accounted for copied or disclosed to any third person.</small> HEDENSTED GRUPPEN A/S	 HEDENSTED GRUPPEN	Scale: 1 : 4	Not specified tolerance according to: DS/ISO 2768-m	Sheet size: A3
	Part No.: 422572	Material:	Surface properties: Ral 9005	Sheet: 1 / 1
	Description 1: Exhaust system for killing box			
Description 2:				

Parts List			
ITEM	QTY	PART NUMBER	DESCRIPTION
1	4	11405012	Hexagon bolt M5x12 FZB
2	4	11408025	Hexagon bolt M8x25 FZB
3	25	140872	Wood screw pan head 5 x 16
4	6	140875	Wood screw countersunk head 5 x 20
5	10	17905000	Self-locking nut M5 FZB
6	4	17908000	Self-locking nut M8 FZB
7	23	19205000	Drive in nut M5 FZB
8	1	280160	HG Mail box complete
9	1	31009	Warning sign. Crushing
10	1	41442	Box part 4
11	1	41446	Box part 6
12	2	41447	Box part 7
13	8,1 m	41592	Sealing strip
14	1	422500	Brace for stand
15	3	422518	Hinge right
16	2	422520	Hinge left
17	1	422531	Box for killing box
18	1	422570	Exhaust/intake for killing box
19	1	422596	Vindow for killing box
20	3	422604	Latch clamp with lock
21	3	422606	Brace for latch clamp
22	4	422608	Brace for gas spring
23	2	422610	Gas spring Ø8 x 200mm, 250N
24	4	422612	Eye bracket for gas spring Ø8mm
25	1	423424	Handle, Ø21 cylindrical knob Ø10
26	6	64405025	Cup head square neck bolt M5x25 FZB
27	2	64485025	Wood screw pan head 4,5 x 35
28	4	76005016	Buttonhead bolt M5x15 FZB
29	42	76005020	Buttonhead bolt M5x20 FZB
30	6	82105900	Washer M5 FZB
31	4	82605000	Washer Ø5,3x15x1,2 FZB
32	1	M100141	Angle for clamp - hydra combi
33	1	M100150	Cover plate
34	1	M100151	Tension brace for hydra combi
35	1	M100840	Tension brace for hydra combi
36	2	M10249	Handle part 2
37	6	M102639	Wood screw pan head 5 x 16 Stainless
38	13	M202005	Wood screw countersunk head 3,5 x 35

422500 may first be mounted whenn it's placed on the stand

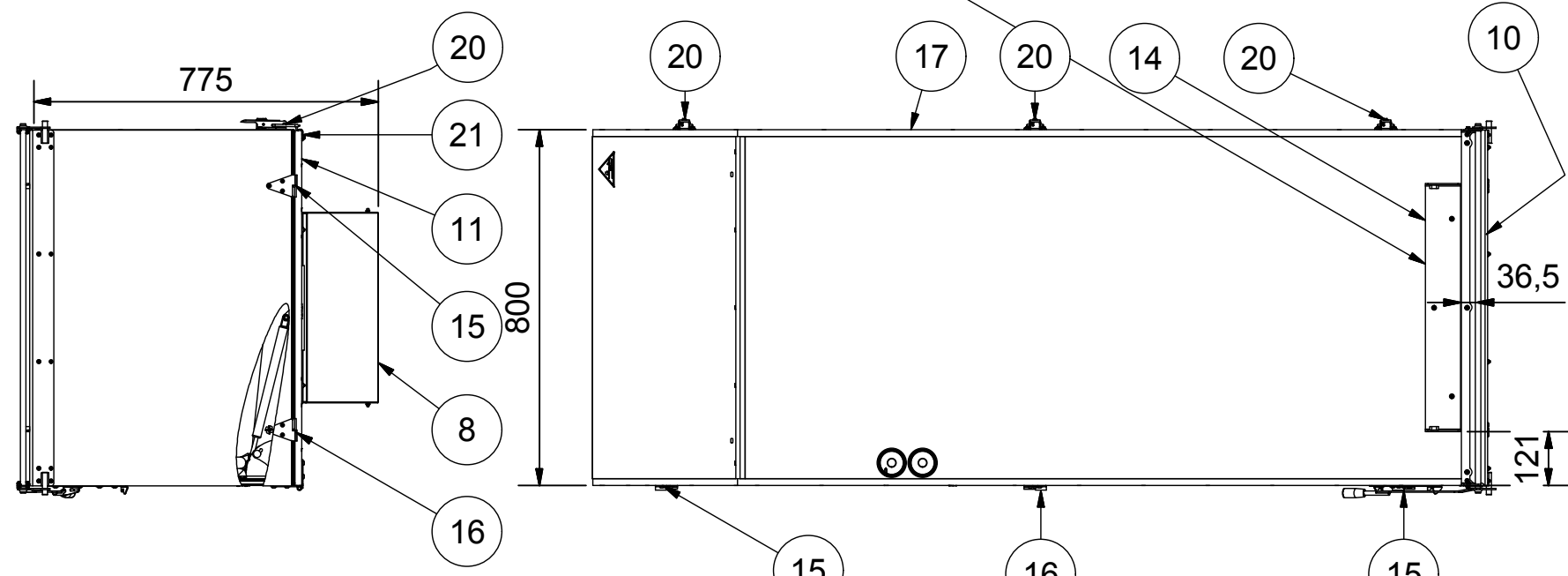

Drill Ø3,5 holes and make countersouk for all screws

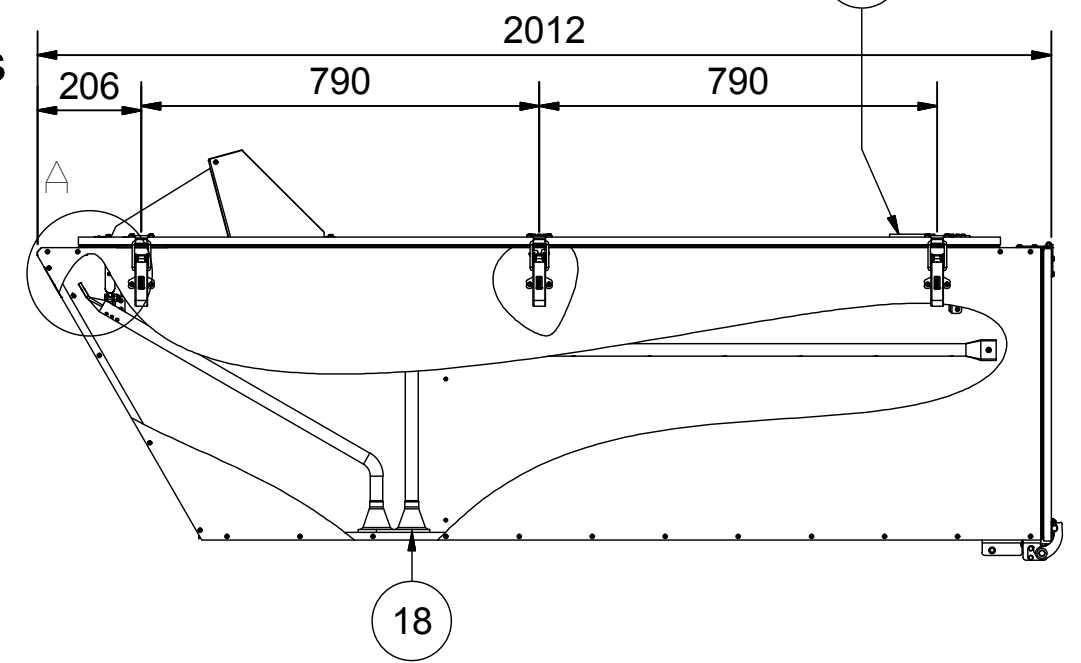
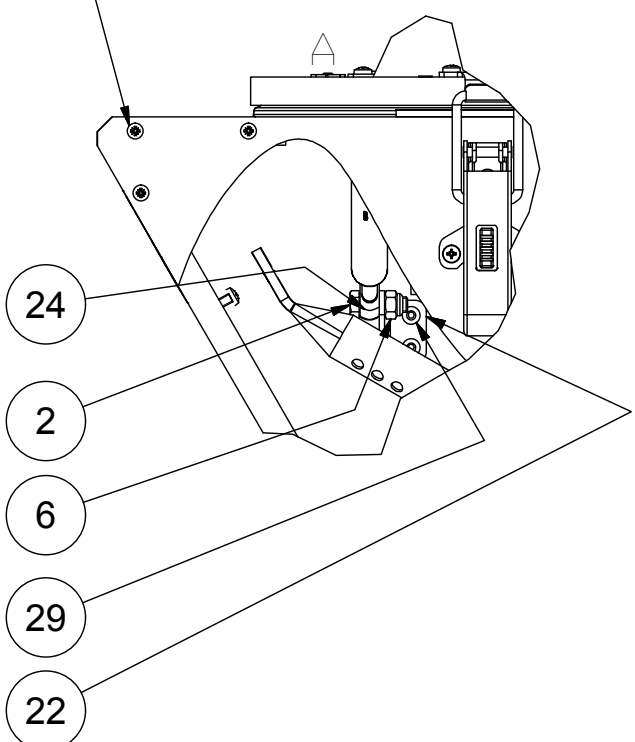

All edges, corners and gabs must be seled with silicone
All edges on the wood must be painted brown

Break all edges

<small>The documents strictly confidential and must not be account be copied or disclosed to any third person.</small> HEDENSTED GRUPPEN A/S	HG	Scale: 1 : 15	Not specified tolerance according to:	Sheet size: A3
	<small>HEDENSTED GRUPPEN</small>		Surface properties:	Sheet: 1 / 3
	Part No.: 422638	Material:		
	Description 1: Killing box			
Description 2:				

Revision:	Approved	Date:	Revision Description
2	KC	28-04-2017	Screws for M100141 added

Parts List			
ITEM	QTY	PART NUMBER	DESCRIPTION
2	4	11408025	Hexagon bolt M8x25 FZB
38	13	M202005	Wood screw countersunk head 3,5 x 35
3	25	140872	Wood screw pan head 5 x 16
4	6	140875	Wood screw countersunk head 5 x 20
5	10	17905000	Self-locking nut M5 FZB
6	4	17908000	Self-locking nut M8 FZB
7	23	19205000	Drive in nut M5 FZB
8	1	280160	HG Mail box complete
9	1	31009	Warning sign. Crushing
10	1	41442	Box part 4
11	1	41446	Box part 6
12	2	41447	Box part 7
14	1	422500	Brace for stand
15	3	422518	Hinge right
16	2	422520	Hinge left
17	1	422531	Box for killing box
18	1	422570	Exhaust/intake for killing box
19	1	422596	Vindow for killing box
20	3	422604	Latch clamp with lock
21	3	422606	Brace for latch clamp
22	4	422608	Brace for gas spring
24	4	422612	Eye bracket for gas spring Ø8mm
26	6	64405025	Cup head square neck bolt M5x25 FZB
29	42	76005020	Buttonhead bolt M5x20 FZB
30	6	82105900	Washer M5 FZB
34	1	M100151	Tension brace for hydra combi
33	1	M100150	Cover plate
36	2	M10249	Handle part 2
32	1	M100141	Angle for clamp - hydra combi
35	1	M100840	Tension brace for hydra combi
25	1	423424	Handle, Ø21 cylindrical knob Ø10
28	4	76005016	Buttonhead bolt M5x15 FZB
1	4	11405012	Hexagon bolt M5x12 FZB
31	4	82605000	Washer Ø5,3x15x1,2 FZB
27	2	64485025	Wood screw pan head 4,5 x 35
13	8,1 m	41592	Sealing strip
37	6	M102639	Wood screw pan head 5 x 16 Stainless
23	2	422610	Gas spring Ø8 x 200mm, 250N

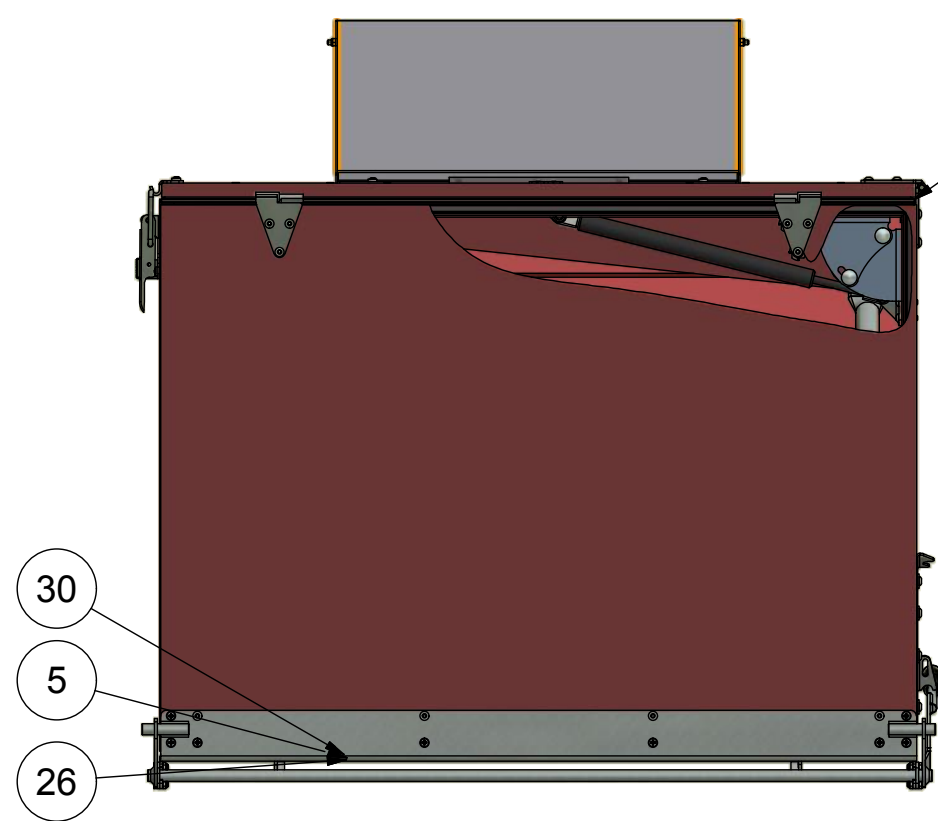
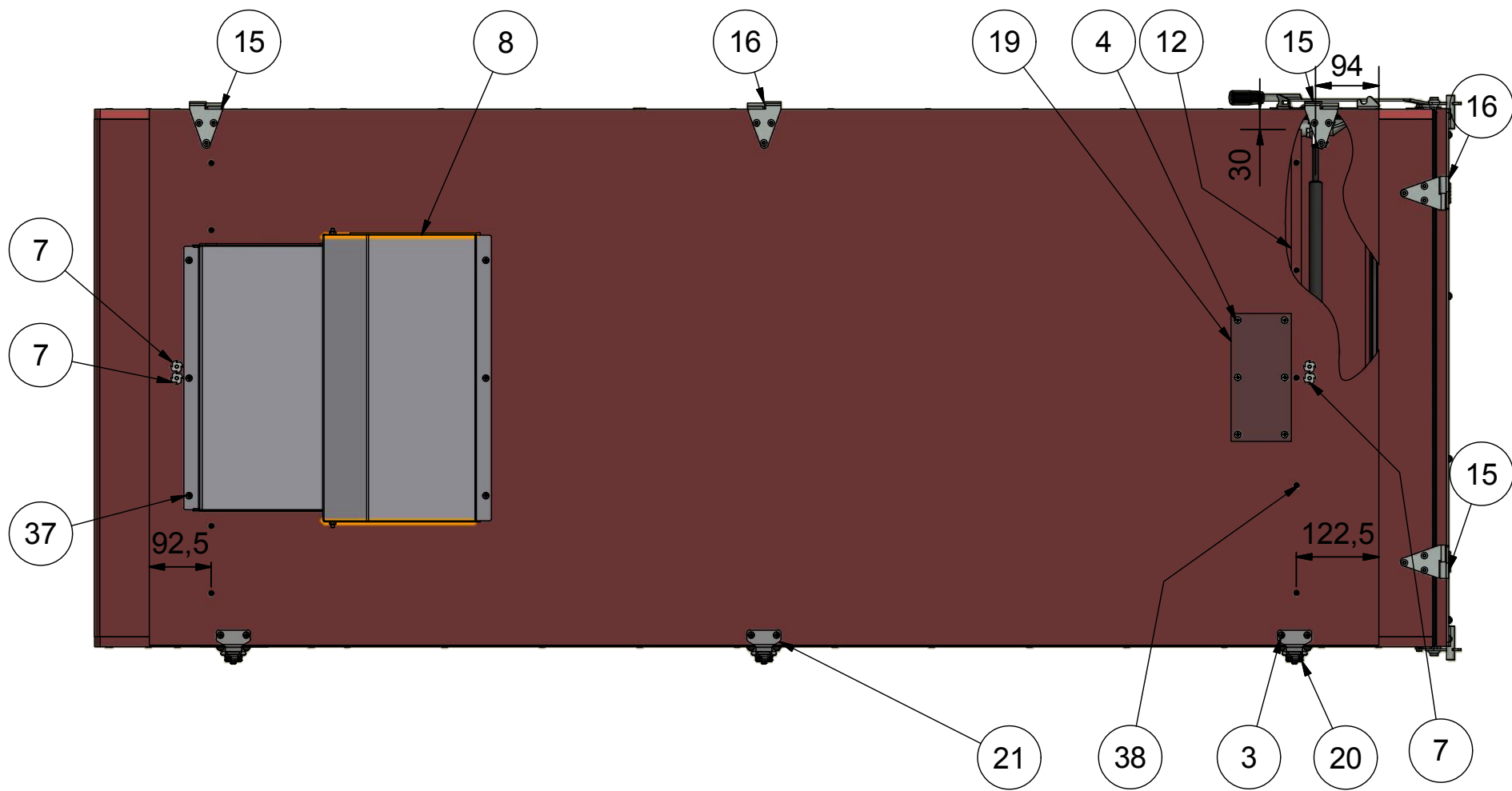

Use zinc plated clamps to fasten rubber sealings

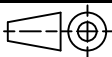
Break all edges		Scale: 1 : 15		Not specified tolerance according to:		Sheet size: A3	
				Surface properties:		Sheet: 2 / 3	
Part No.: 422638		Material:					
Description 1: Killing box							
Description 2:							

Revision:	Approved	Date:	Revision Description
2	KC	28-04-2017	Screws for M100141 added

This document is strictly confidential and must not be accounted for copied or disclosed to any third person.
 HEDENSTED GRUPPEN A/S

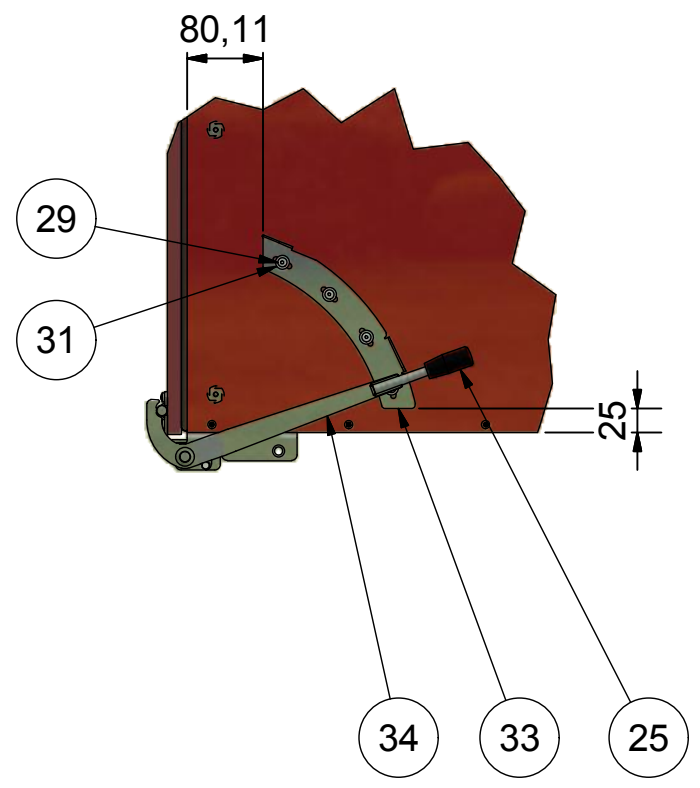
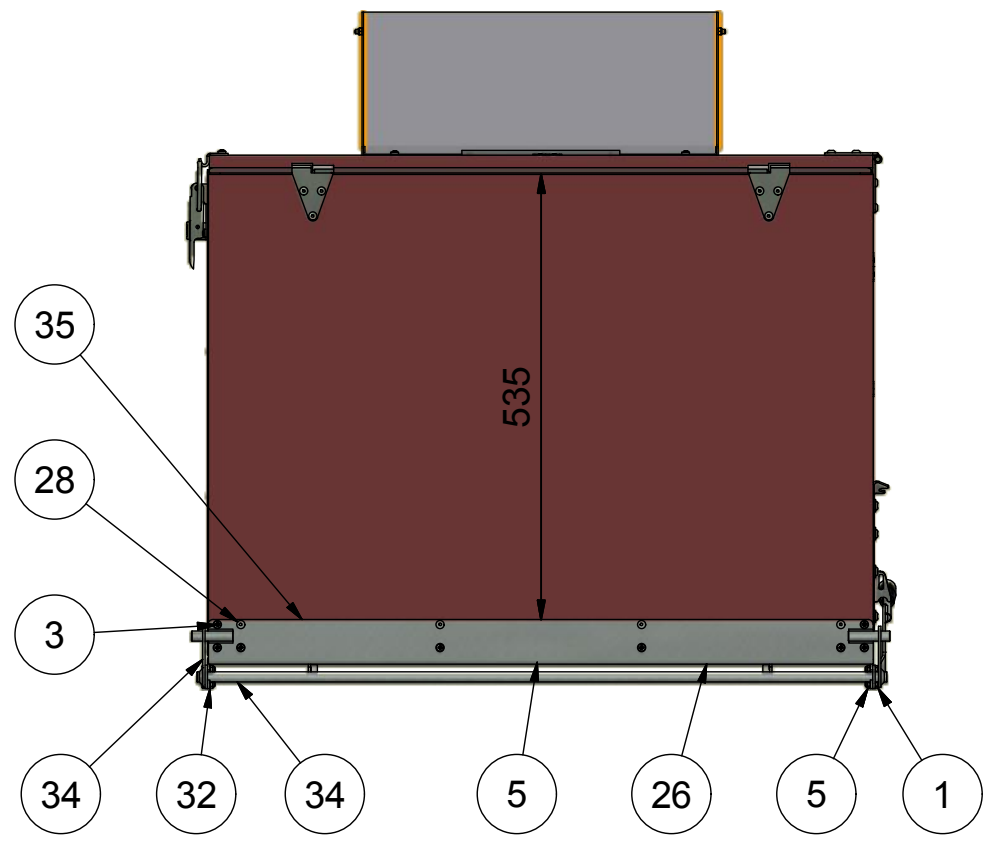
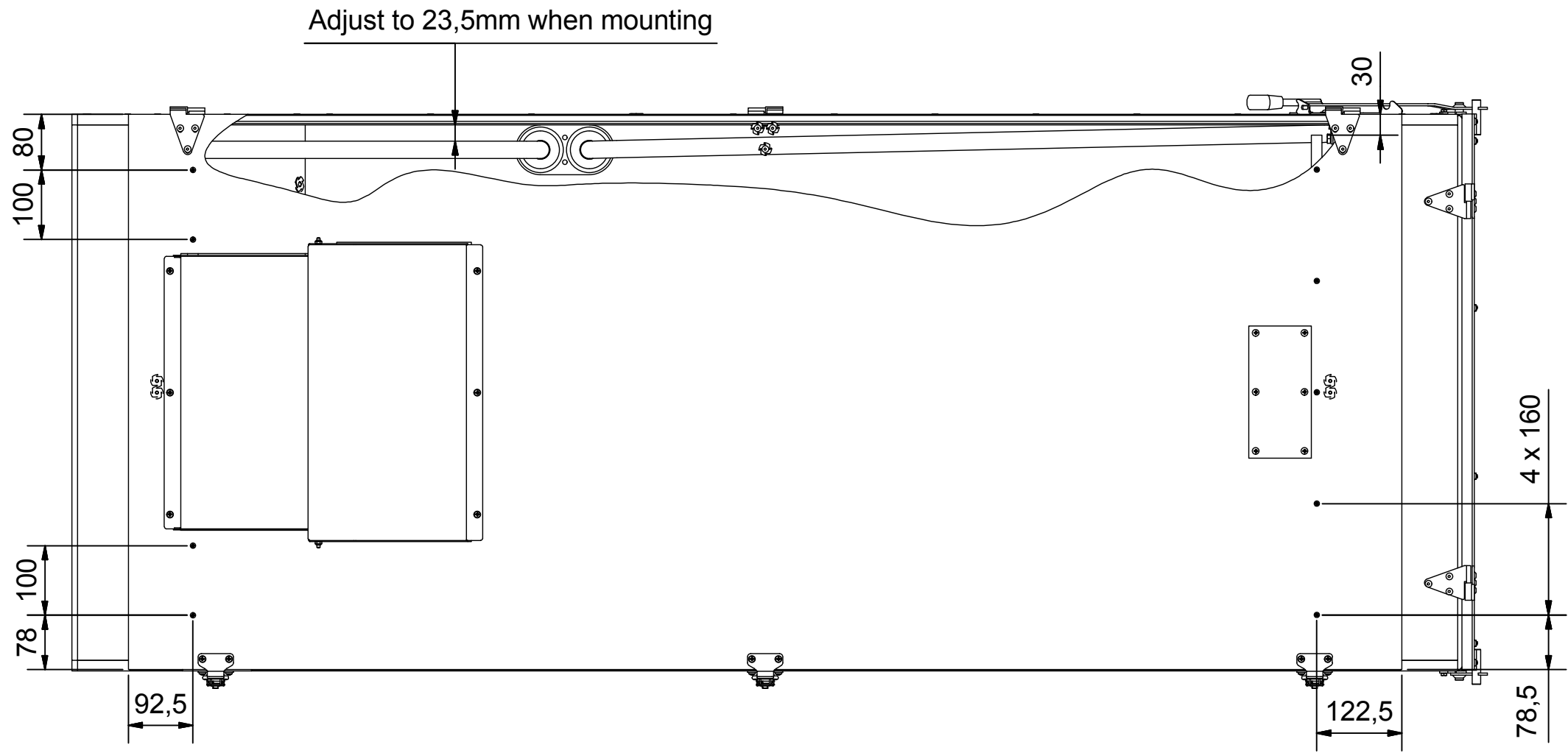

Break all edges

The document is strictly confidential and must not be accounted for copied or disclosed to any third person. HEDENSTED GRUPPEN A/S	HG	Scale:	Not specified tolerance according to:	Sheet size:
	HEDENSTED GRUPPEN	1 : 15		A3
	Part No.:		Surface properties:	Sheet:
	422638			3 / 3
Description 1:		Material:		
Killing box				
Description 2:				

Revision:	Approved	Date:	Revision Description
2	KC	28-04-2017	Screws for M100141 added

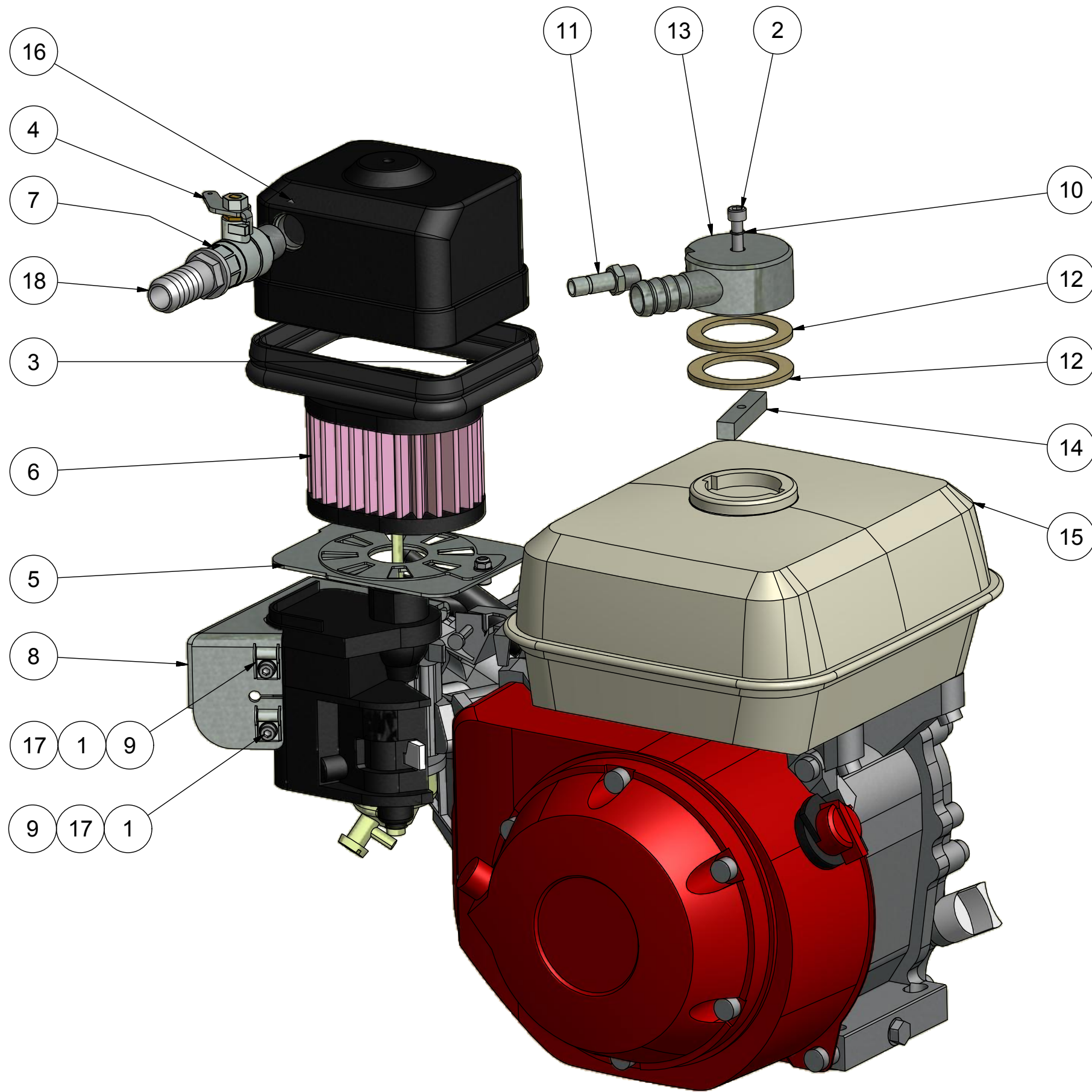

Parts List

ITEM	QTY	PART NUMBER	DESCRIPTION
1	2	10205012	Hexagon cylinder head M5x12 FZB
2	1	10206050	Hexagon cylinder head M6x50 FZB
3	0,5 m	203930	Edge protecting strip
4	1	422576	Brace for Ball valve
5	1	422582	Draught control main assembly
6	1	422646	Air filter K&N Honda GX200
7	1	422648	Ball valve 1/2" (M/F)
8	1	423415	Throttle-Choke brace
9	2	423419	Cable clamp
10	1	423444	O-ring OR6,00-1,00
11	1	423446	Reduction stem Ø10 x 1/4" pipe Metal
12	2	423627	Gasket for fueltank
13	1	43356	External fuel cap
14	1	43359	Tension brace
15	1	441705	HONDA GX200UT SXE5 electrical start
16	1	58013000	Lock nut WRG 1/2"
17	2	82105900	Washer M5 FZB
18	1	852520	Hose nipple Ø1/2" x 20ug Composite

Break all edges

The document is strictly confidential and must not be accounted for copied or disclosed to any third person. HEDENSTED GRUPPEN A/S		Scale:	Not specified tolerance according to:	Sheet size:
		1 : 2,5	DS/ISO 2768-m	A3
Part No.: 422658		Surface properties:		Sheet:
				1 / 1
Description 1: Engine assembly 1				
Description 2:				

Revision:	Approved	Date:	Revision Description
1	HG	28-09-2015	Revision changed to numeric

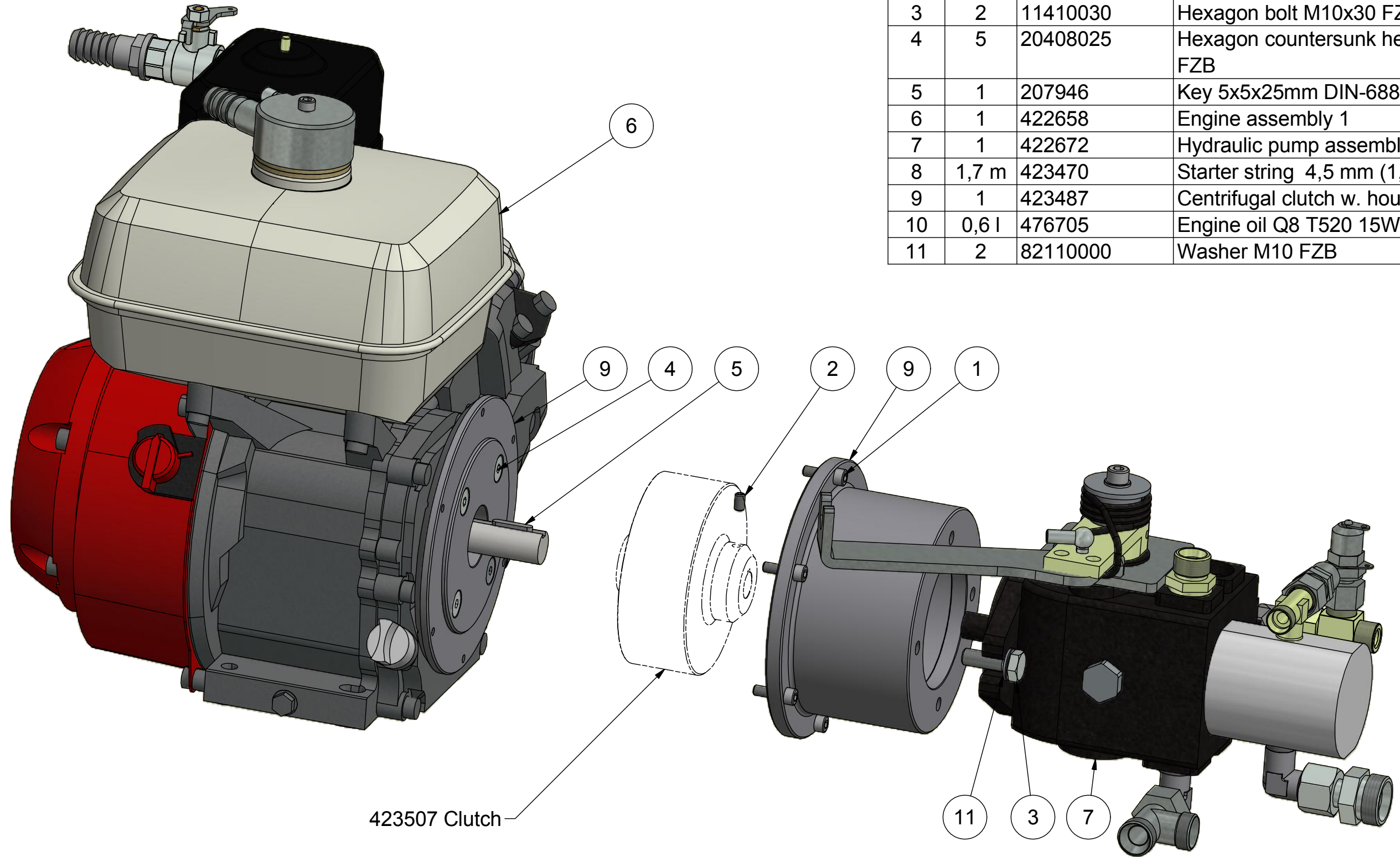

423507 Clutch

Parts List

ITEM	QTY	PART NUMBER	DESCRIPTION
1	6	10206020	Hexagon cylinder head M6x20 FZB
2	1	10506010	Stop screw M6x10-B
3	2	11410030	Hexagon bolt M10x30 FZB
4	5	20408025	Hexagon countersunk head M8x25 FZB
5	1	207946	Key 5x5x25mm DIN-6885A
6	1	422658	Engine assembly 1
7	1	422672	Hydraulic pump assembly
8	1,7 m	423470	Starter string 4,5 mm (1,58m)
9	1	423487	Centrifugal clutch w. housing
10	0,6 l	476705	Engine oil Q8 T520 15W-40
11	2	82110000	Washer M10 FZB

Break all edges

The documents are confidential and must not be accounted for copied or disclosed to any third person. HEDENSTED GRUPPEN A/S	 HEDENSTED GRUPPEN	Scale: 1 : 2,5	Not specified tolerance according to:	Sheet size: A3
	Part No.: 422660	Material:	Surface properties:	Sheet: 1 / 1
	Description 1: Engine assembly 2			
	Description 2:			

Revision:	Approved	Date:	Revision Description
1	HG	28-09-2015	Revision changed to numeric

Parts List

ITEM	QTY	PART NUMBER	DESCRIPTION
1	1	10206030	Hexagon cylinder head M6x30 FZB
2	2	10208020	Hexagon cylinder head M8x20 FZB
3	1	423528	Brace for steering cable
4	1	423530	Hydrostate pump
5	1	424047	Adjustable elbow 12L DM
6	1	424060	T-pipe screw connection Ø12-L
7	1	424075	Hose nipple Ø1" x 3/4"
8	1	424176	L-Fitting 12L-3/8
9	1	47104	3/4" Vinkel M/M Galv
10	1	477072	Adjustable tee SL15 L
11	1	477097	Male stud 3/8" x 3/4" PP
12	1	477110	Male stud 12L 1/4"
13	1	477120	Male stud Ø15-L 1/2" DM
14	1	477141	Elbow 15L 1/2" K DM
15	1	477146	Elbow 15L 3/8"
16	1	477163	Bopnded seal washer 3/8"
17	1	477208	Steam reducer 15L 22L
18	2	477272	Male test niple 12L
19	1	489103	Ball joint AS08-M05 Formatic
20	2	82108000	Chamfered Washer M8 FZB

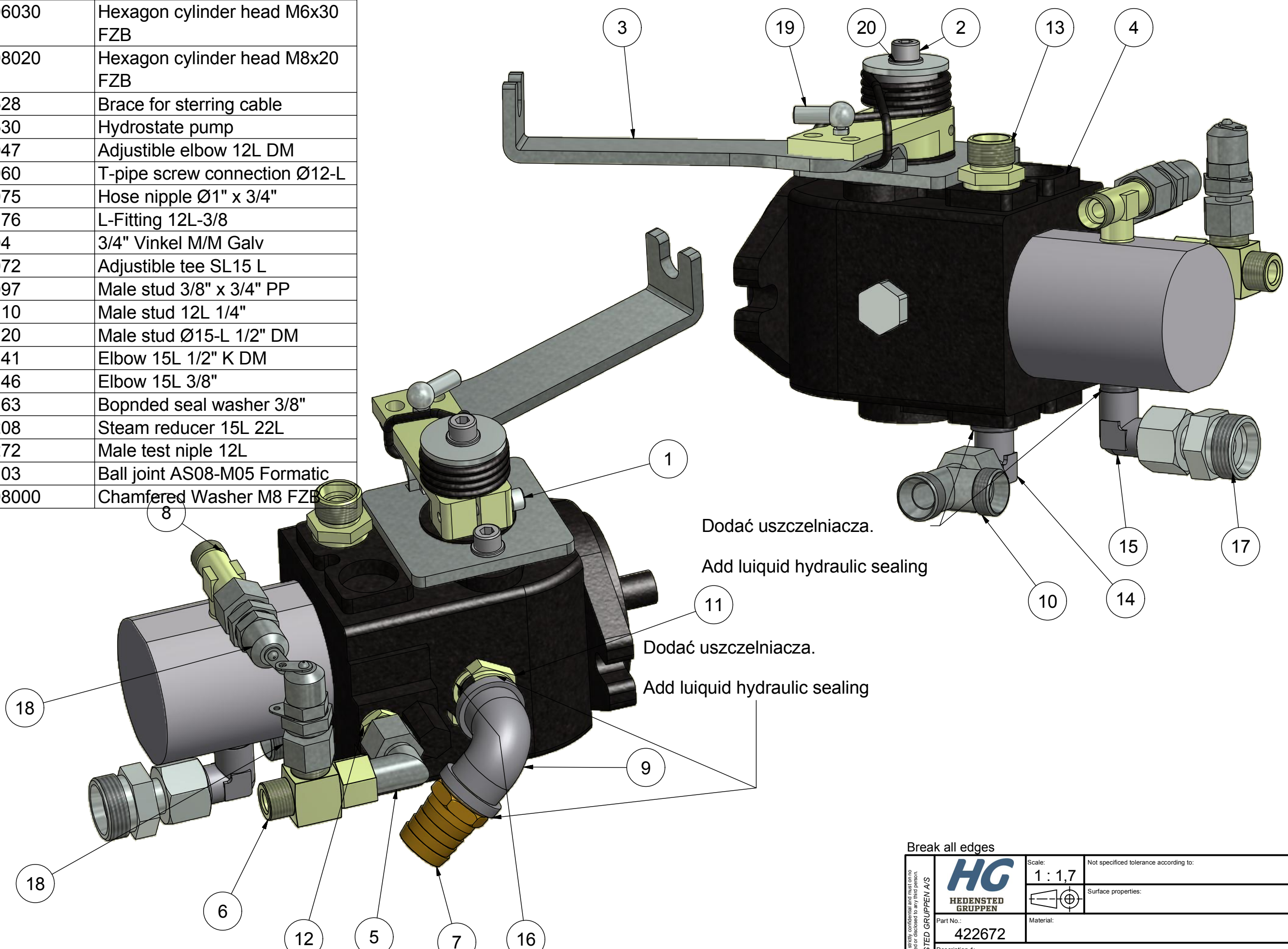

Dodać uszczelniacza.

Add liquid hydraulic sealing

Dodać uszczelniacza.

Add liquid hydraulic sealing

Break all edges

The documents are confidential and must not be copied or disclosed to any third person. HEDENSTED GRUPPEN A/S		Scale: 1 : 1,7	Not specified tolerance according to:	Sheet size: A3
	HEDENSTED GRUPPEN		Surface properties:	Sheet: 1 / 2
	Part No.: 422672	Material:		
	Description 1: Hydraulic pump assembly			
Description 2:				

Revision:	Approved	Date:	Revision Description
1	HG	28-09-2015	Revision changed to numeric

PARTS LIST

ITEM	QTY	PART NUMBER	DESCRIPTION
1	2	11408065	Hexagon bolt M8x65 FZB
2	2	1508000	Nut M8 FZB
3	2	17908000	Self-locking nut M8 FZB
4	1	423424	Handle, Ø21 cylindrical knob Ø10
5	1	423522	Handle for tilt valve
6	1	423526	Hydraulic tilt valve
7	1	477105	Elbow 3/8"t x 3/8"t (M/M)
8	2	477139	Elbow 3/8"t x Ø12L
9	2	477163	Bopnded seal washer 3/8"
10	1	477222	Banjo bolt 3/8"
11	4	82108000	Washer M8 FZB

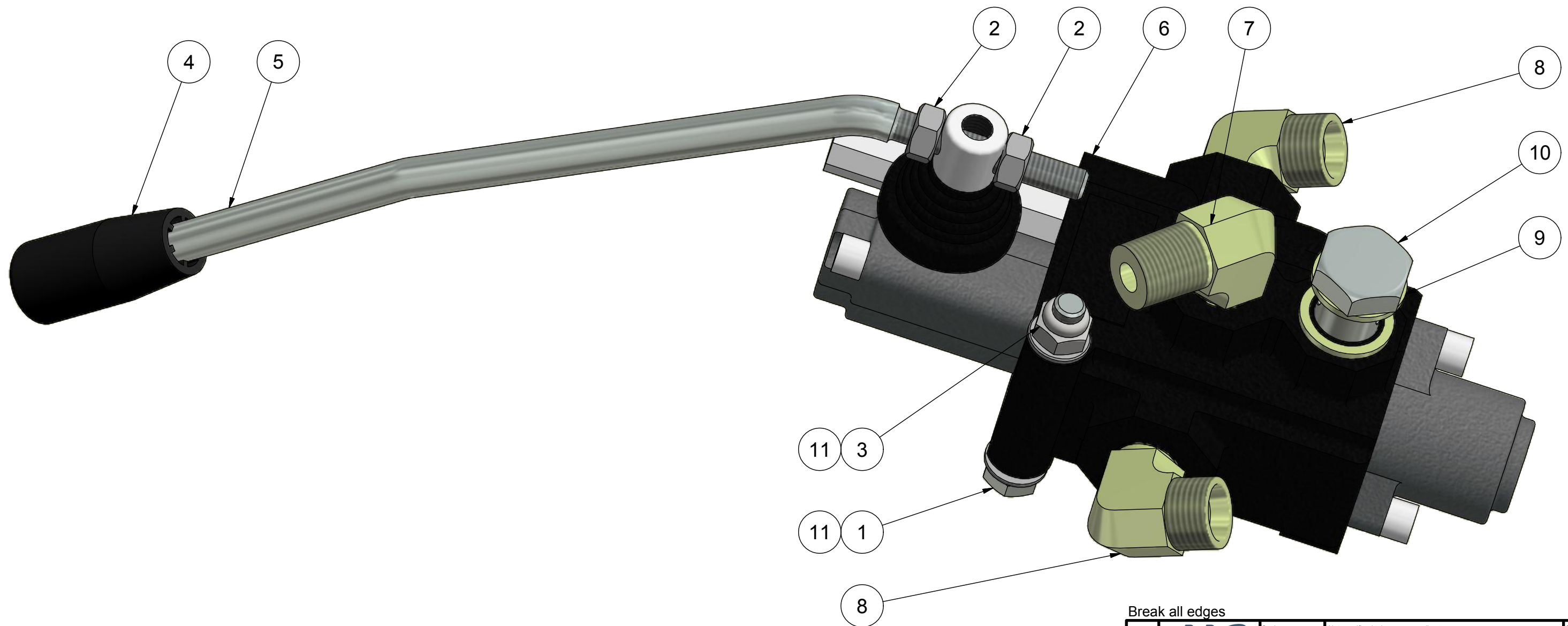

Break all edges

This document is strictly confidential and must not be accounted for copied or disclosed to any third person. HEDENSTED GRUPPEN A/S	 HEDENSTED GRUPPEN	Scale: 1 : 1	Not specified tolerance according to: DS/ISO 2768-m	Sheet size: A3
	Part No.: 422663	Material:	Surface properties: No	Sheet: 1 / 2
	Description 1: Tilt valve assambly 2014			
	Description 2: Hydra combi + SS			



Revision:	Approved	Date:	Revision Description
1	HG	27-09-2015	Revision changed to numeric

Parts List

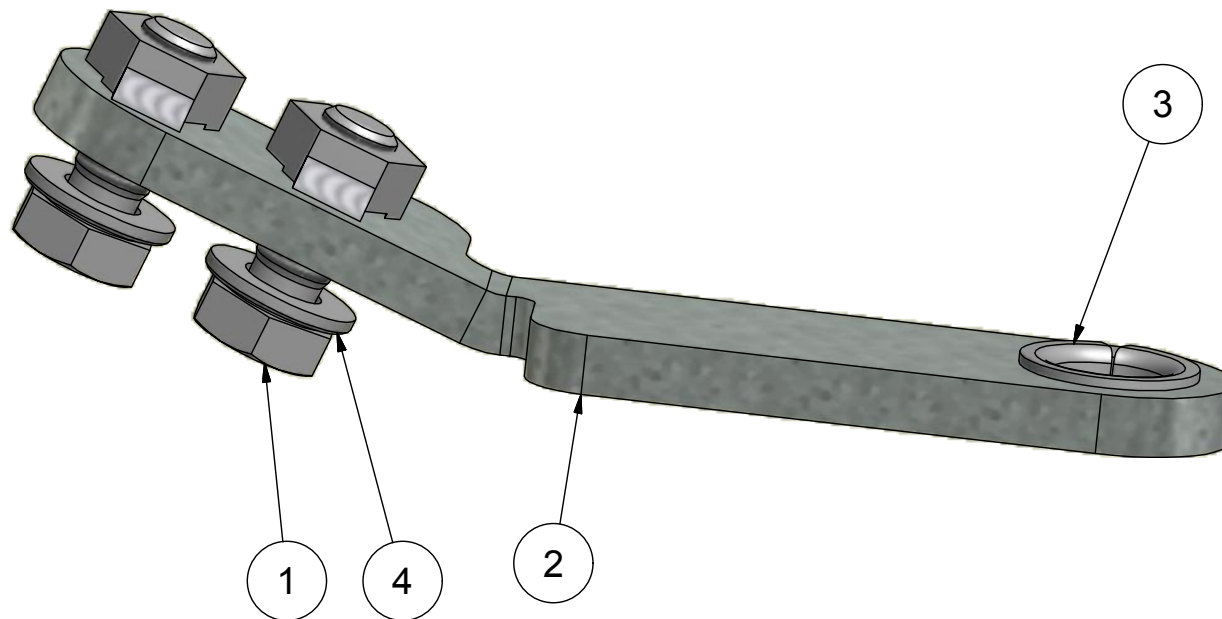
ITEM	QTY	PART NUMBER	DESCRIPTION
1	2	11408020	Hexagon bolt M8x20 FZB
2	1	422534	Bearing for handle
3	1	423423	Slide Bearing PAF 12070 P10
4	2	82108000	Chamfered Washer M8 FZB



Break all edges

This document is strictly confidential and must not be copied or disclosed to any third person. HEDENSTED GRUPPEN A/S	 HEDENSTED GRUPPEN	Scale: 2 : 1,5	Not specified tolerance according to: DS/ISO 2768-m	Sheet size: A4
			Surface properties:	Sheet: 1 / 1
	Part No.: 422664	Material:		
	Description 1: Assembly bearing for handle			
Description 2:				

Revision:	Approved	Date:	Revision Description
1	HG	28-09-2015	Revision changed to numeric

Parts List

ITEM	QTY	PART NUMBER	DESCRIPTION
1	2	10205012	Hexagon cylinder head M5x12 FZB
2	2	11408020	Hexagon bolt M8x20 FZB
3	2	17910000	Self-locking nut M10 FZB
4	1	423412	Brace for throttle and choke
5	1	423413	Gas choke handle right
6	2	423419	Cable clamp
7	1	423426	Gas/choke handle left
11	2	82105900	Washer M5 FZB
8	2	82108000	Washer M8 FZB
9	4	82110000	Washer M10 FZB
10	4	89310080	Disc spring 20x10,5x0,8

Bend the plate so it works as stops for the handles

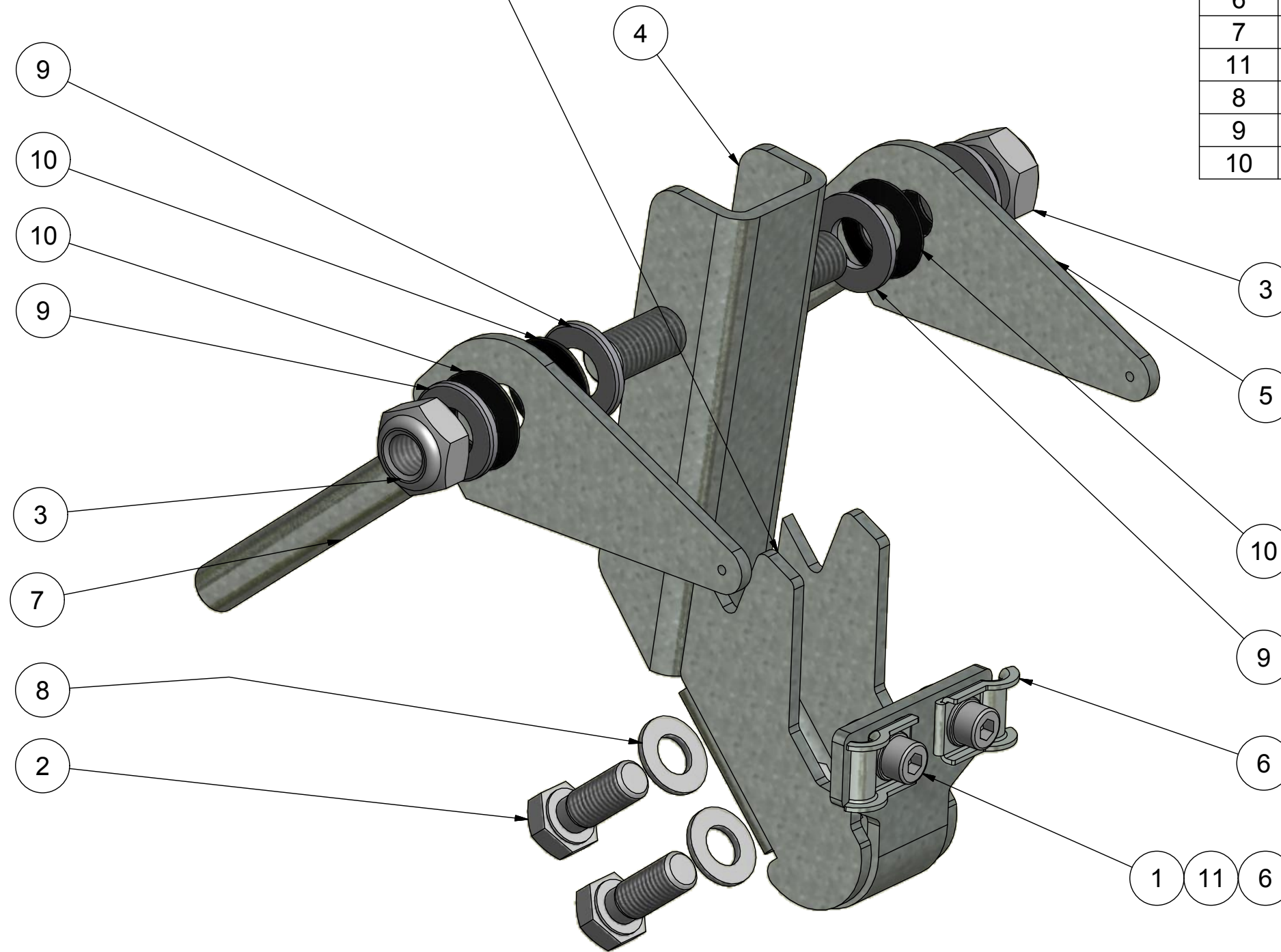

Break all edges

The document is strictly confidential and must not be accounted for copied or disclosed to any third person. HEDENSTED GRUPPEN A/S		Scale: 1:1	Not specified tolerance according to: DS/ISO 2768-m	Sheet size: A3
		Surface properties:		Sheet: 1/1
Part No.: 422666		Material:		
Description 1: Throttle/choke assembly				
Description 2:				

Revision:	Approved	Date:	Revision Description
1	HG	28-09-2015	Revision changed to numeric

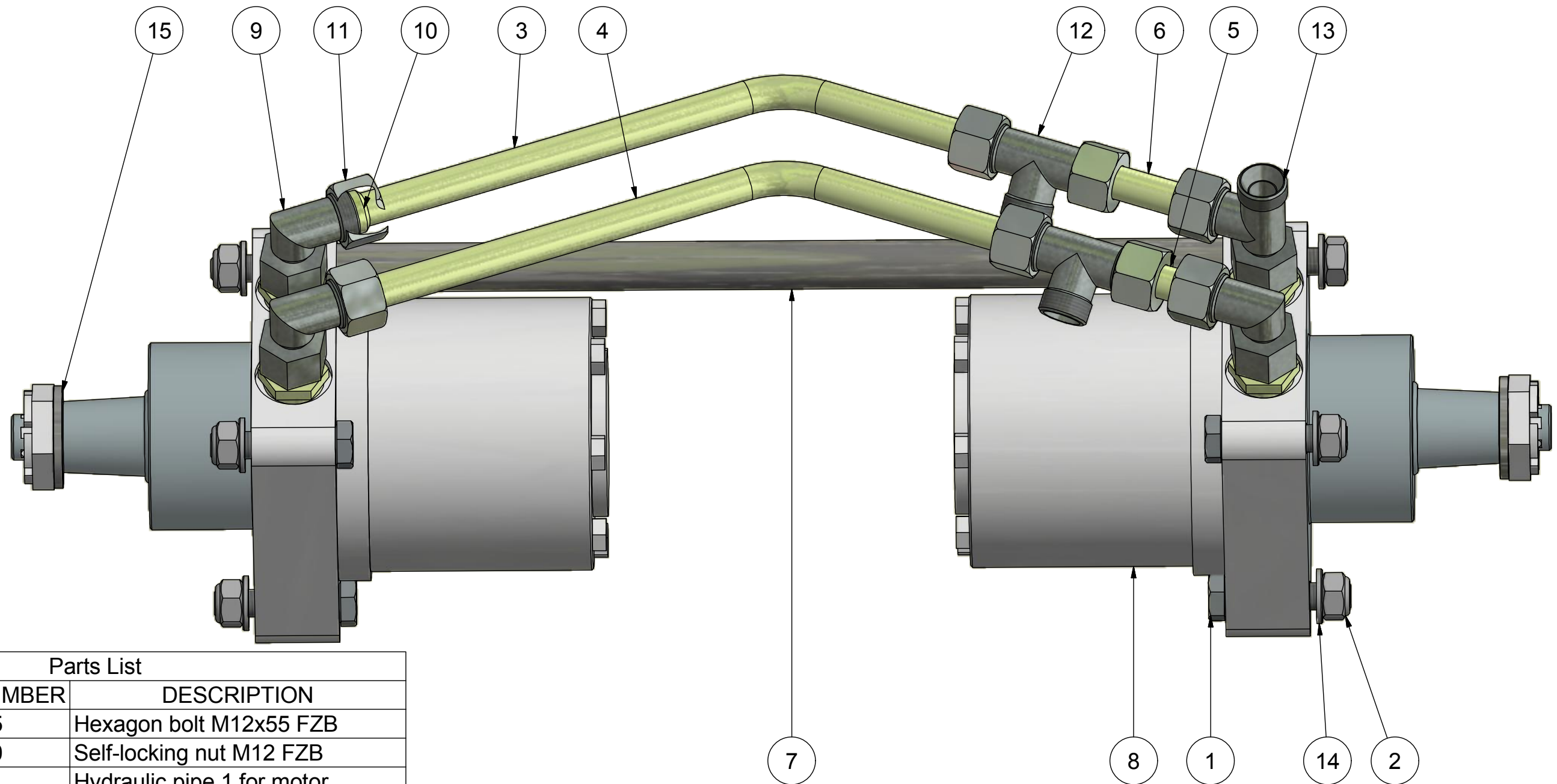

Parts List

ITEM	QTY	PART NUMBER	DESCRIPTION
1	6	11412055	Hexagon bolt M12x55 FZB
2	7	17912000	Self-locking nut M12 FZB
3	1	422624	Hydraulic pipe 1 for motor
4	1	422626	Hydraulic pipe 2 for motor
5	1	422628	Hydraulic pipe 3 for motor
6	1	422630	Hydraulic pipe 4 for motor
7	1	423442	Pipe for wheel motor
8	2	423519	Wheel motor 347ccm Eaton delta
9	3	424048	Elbow adjustable Ø15L w. o-ring Ø15L
10	8	424118	Cutting ring Ø15L
11	8	424122	Union Ø15L M22x1,5
12	2	424162	Tee 3x Ø15L
13	1	477072	Tee Adjustable Ø15L x Ø15L x Ø15L (M/F/F)
14	8	82112000	Washer M12 FZB
15	2	423545	Washer f/OMRW 45x20,5x4 FZB
17	4	477145	Straight connector w. gasket Ø15L 7/8"-14 UNF

Revision	Approved	Date	Revision Description
1	HG	28-09-2015	Revision changed to numeric

Break all edges

The documents strictly confidential and must not be accounted for copied or disclosed to any third person. HEDENSTED GRUPPEN A/S	 HEDENSTED GRUPPEN	Scale: 1 : 2	Not specified tolerance according to: DS/ISO 2768-m	Sheet size: A3
	Part No.: 422668	Material:	Surface properties:	Sheet: 1 / 2
Description 1: Wheel motor assembly				
Description 2:				

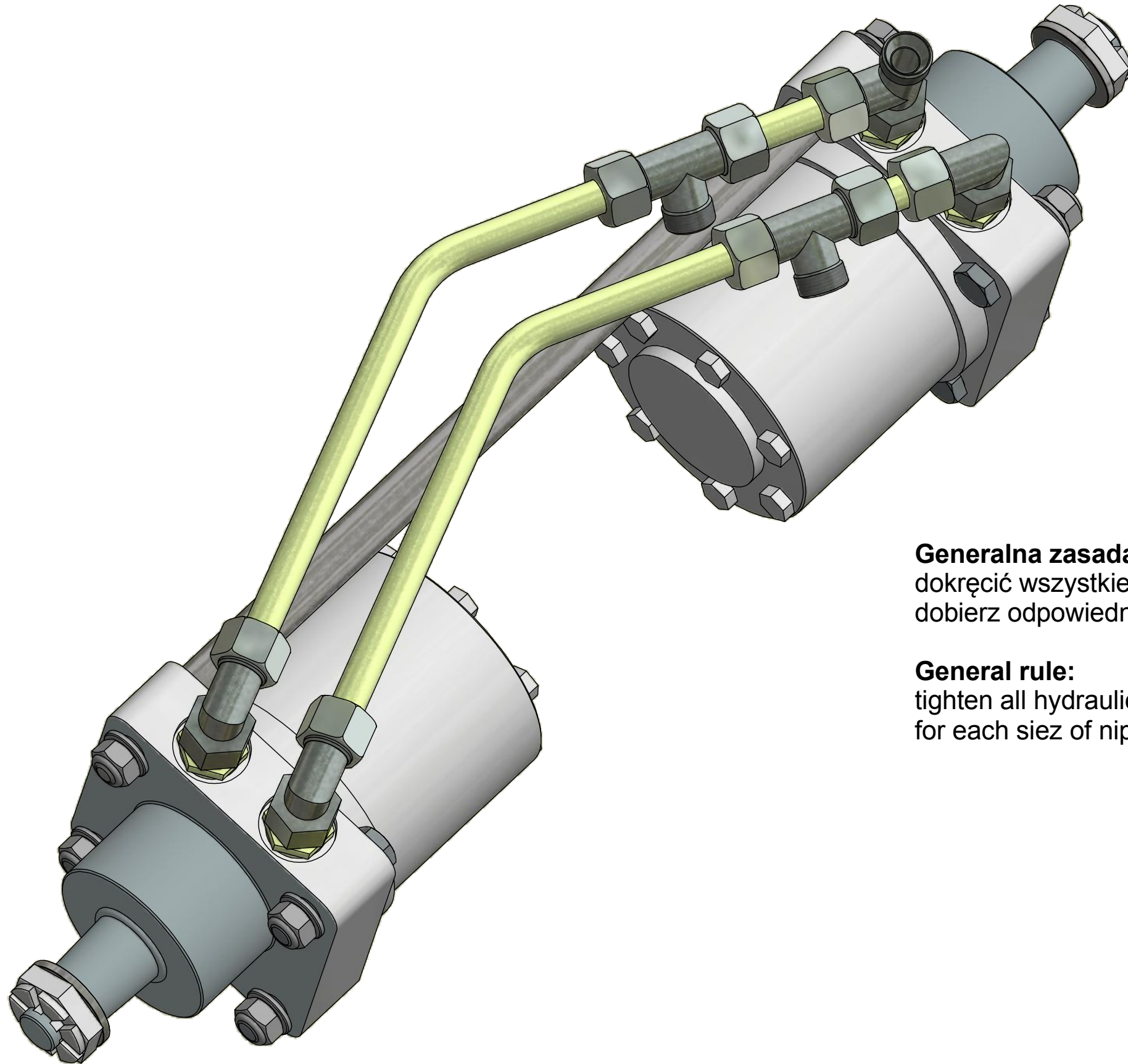

Generalna zasada:

dokręcić wszystkie złączki hydrauliczne z odpowiednią siłą -
dobierz odpowiednią siłę do rozmiaru złączki zgodnie z tabelą.

General rule:

tighten all hydraulic nipples with correct force -
for each size of nipple use correct force according to table.

Break all edges

Revision:	Approved	Date:	Revision Description
1	HG	28-09-2015	Revision changed to numeric

The document is strictly confidential and must not be account be copied or disclosed to any third person. HEDENSTED GRUPPEN A/S	 HEDENSTED GRUPPEN	Scale: 1 : 2	Not specified tolerance according to: DS/ISO 2768-m	Sheet size: A3
	Part No.: 422668	Material:	Surface properties:	Sheet: 2 / 2
Description 1: Wheel motor assembly				
Description 2:				

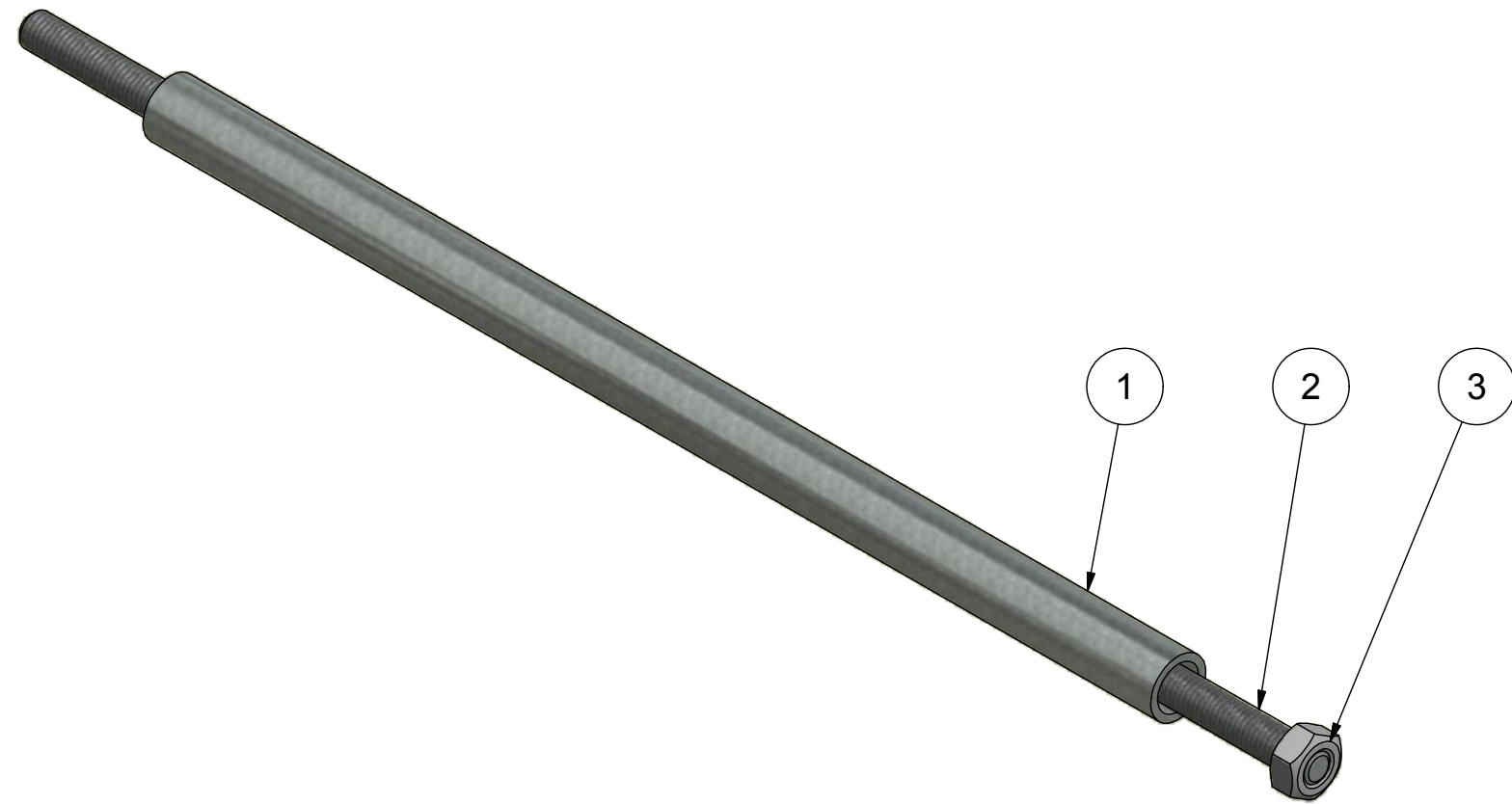
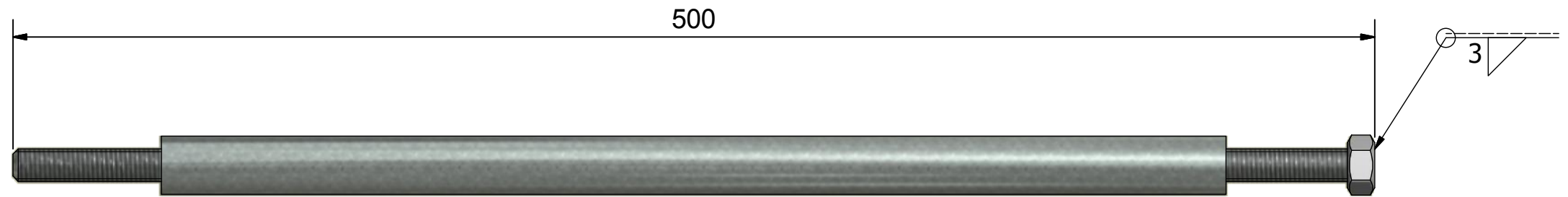

Parts List

ITEM	QTY	PART NUMBER	DESCRIPTION
1	1	43236	Spacer for wheel motor
2	1	43238	Thread rod for spacer
3	1	1512000	Nut M12 FZB

Revision:	Approved	Date:	Revision Description
1	HG	28-09-2015	Revision changed to numeric

Break all edges

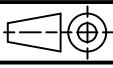
<small>The document is strictly confidential and must not be disclosed to any third person.</small> HEDENSTED GRUPPEN A/S	 HEDENSTED GRUPPEN	Scale: 1 : 2	Not specified tolerance according to: DS/ISO 2768-m	Sheet size: A3
	Part No.: 423442		Surface properties: Zinc chromated	Sheet: 1 / 1
	Description 1: Pipe for wheel motor			
	Description 2:			

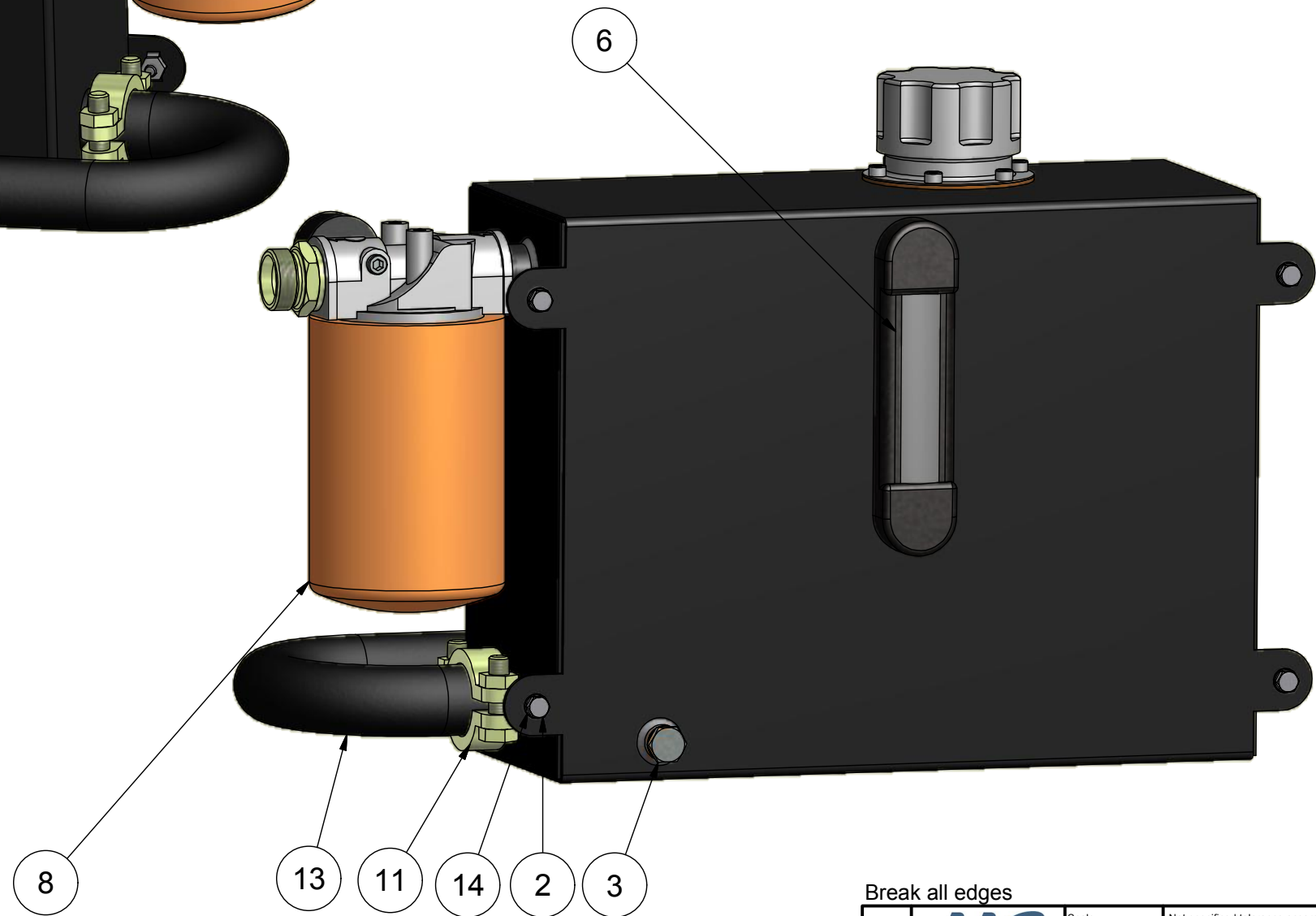
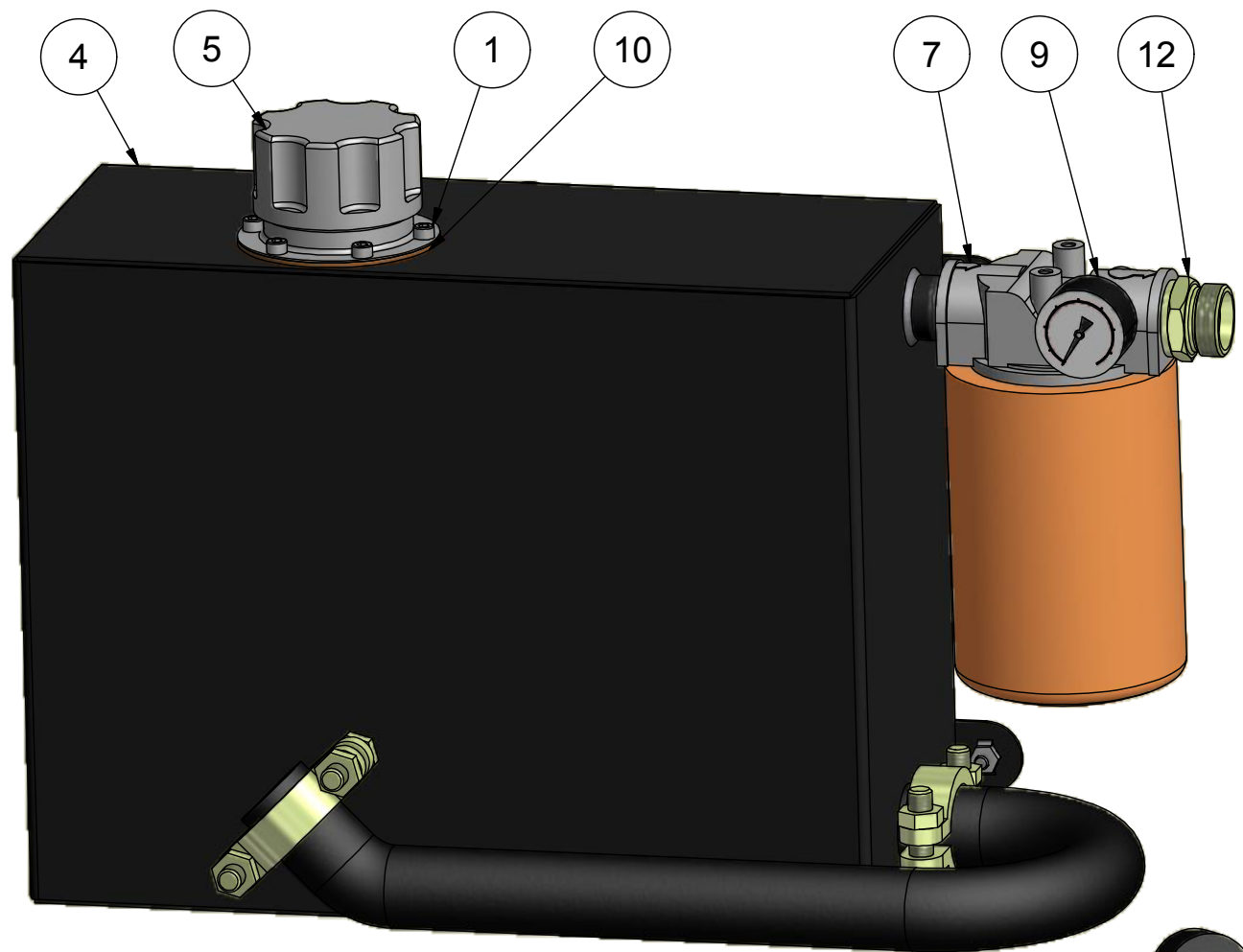

Parts List

ITEM	QTY	PART NUMBER	DESCRIPTION
1	6	10205010	Hexagon cylinder head M5x10 FZB
2	4	11406016	Hexagon bolt M6x16 FZB
3	1	216739	Plug male 1/4"
4	1	422516	Hydraulic tank
5	1	423459	Påfyldning HB70
6	1	423460	Oil level indicator
7	1	423556	Filter head
8	1	423558	MP Oil filter
9	1	423810	Gauge -1+2 bar 1/8" Ø40
10	1	423918	Gasket for filler neck
11	2	474206	Hose clamp Ø32-40
12	1	477126	Male stud 22L 3/4" DM
13	1	477422	Hydraulic hose 10. 1" x530mm ¹
14	4	82106000	Chamfered Washer M6 FZB

REVISION HISTORY

REV	DESCRIPTION	DATE	APPROVED
A	Made	05-01-2011	KC
HG	Revision changed to numeric	21-02-2012	KL

Break all edges

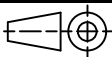
<small>The documents strictly confidential and must not be accounted for copied or disclosed to any third person.</small> HEDENSTED GRUPPEN A/S	 HEDENSTED GRUPPEN	Scale: 1:3 	Not specified tolerance according to: DS/ISO 2768-m Surface properties:	Sheet size: A3 Sheet: 1/2
	Part No.: 422670 Description 1: Hydraulic tank assembly Description 2:	Material:		

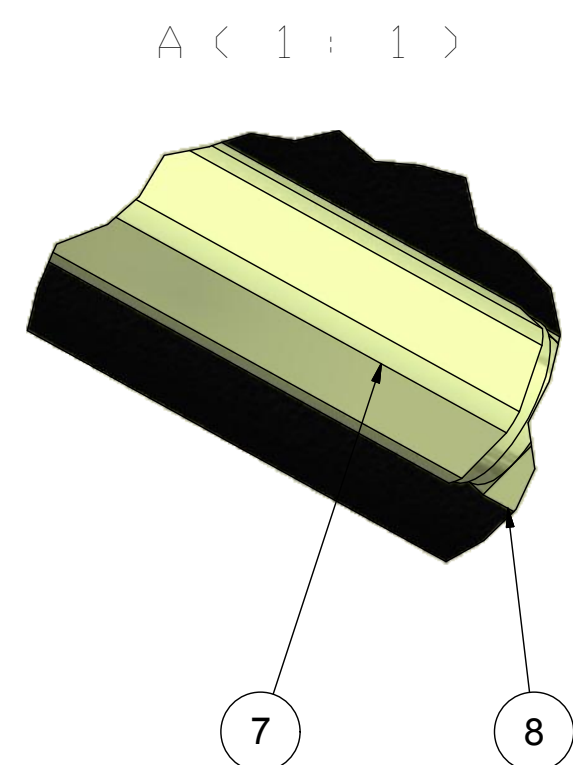
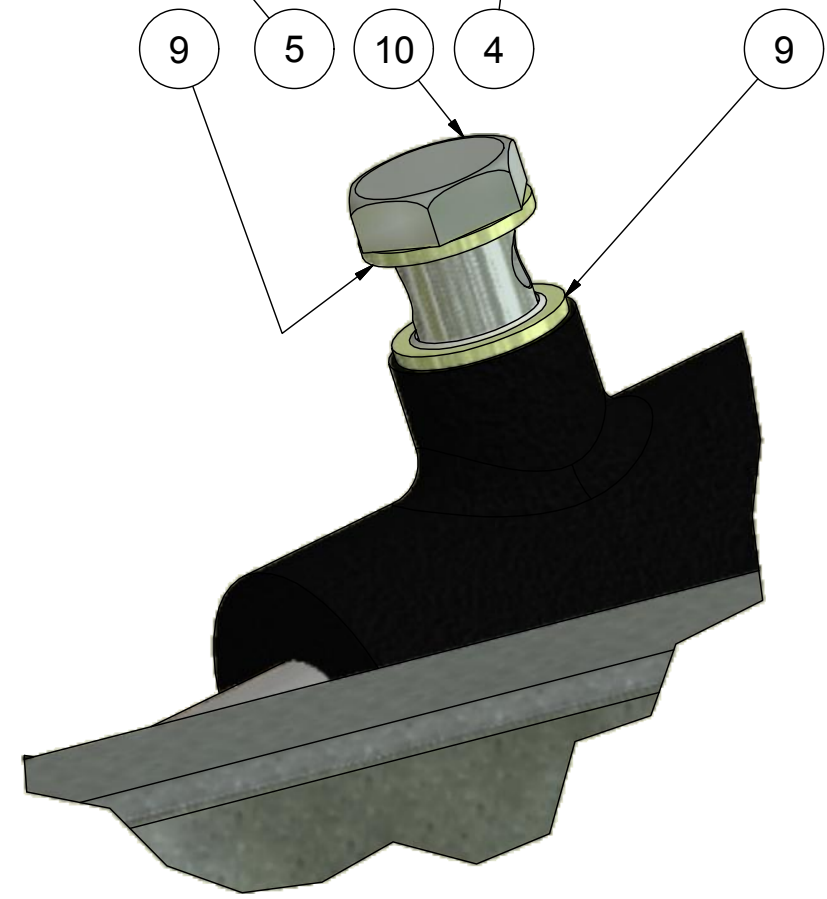

A < 1 : 1 >

Parts List

ITEM	QTY	PART NUMBER	DESCRIPTION
1	5	11408016	Hexagon bolt M8x16 FZB
2	1	41468	Stand part 11
3	1	41470	Stand part 12
4	1	422502	Cylinder for Hydra Combi
5	1	422532	Stand
6	4	423409	Lock pin for cylinder
7	1	423462	Hose leak valve
8	1	477100	Straight connector 3/8" x 3/8"
9	3	477163	Bopnded seal washer 3/8"
10	1	477222	Banjo bolt 3/8"

Revision:	Approved	Date:	Revision Description
1	HG	28-09-2015	Revision changed to numeric

Break all edges

<small>The documents strictly confidential and must not be account be copied or disclosed to any third person.</small> HEDENSTED GRUPPEN A/S	 HEDENSTED GRUPPEN	Scale: 1 : 5	Not specified tolerance according to: DS/ISO 2768-m	Sheet size: A3
	Part No.: 422674	Material:	Surface properties:	Sheet: 1 / 1
Description 1: Stand assembly				
Description 2:				

Parts List

ITEM	QTY	PART NUMBER	DESCRIPTION
1	2	10212050	Hexagon cylinder head M12x50 FZB
2	1	421419	Negative terminal
3	2	423467	Brace for battery
4	1	423496	Cover for positive terminal
5	1	423497	Cover for gorund terminal
6	1	423529	Positive terminal
7	1	476010	Battery

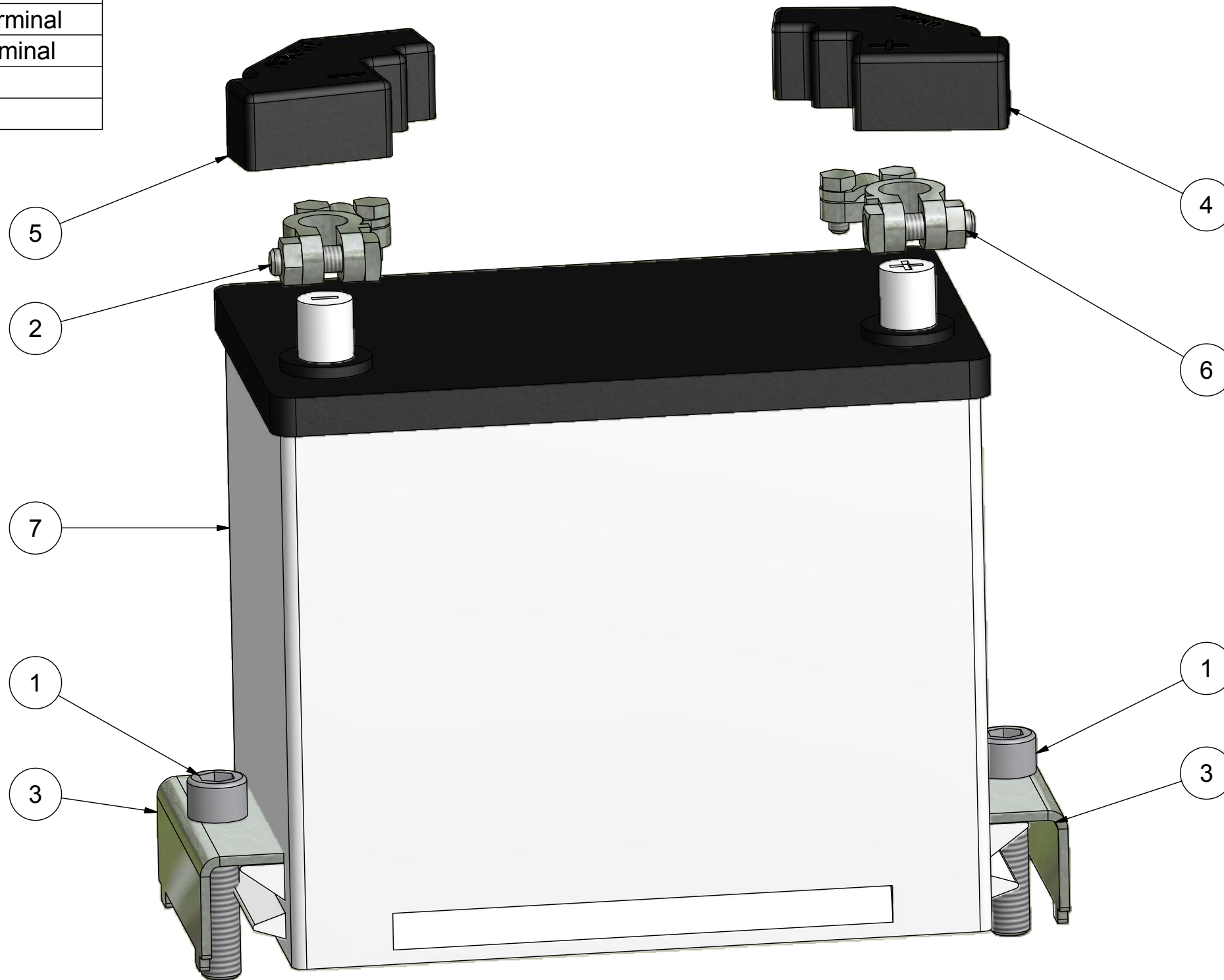

Break all edges

The document is strictly confidential and must not be account be copied or disclosed to any third person. HEDENSTED GRUPPEN A/S	 HEDENSTED GRUPPEN	Scale: 1 : 1,5	Not specified tolerance according to: DS/ISO 2768-m	Sheet size: A3
	Part No.: 422676	Material:	Surface properties:	Sheet: 1 / 1
Description 1: Battery assembly				
Description 2:				

Revision:	Approved	Date:	Revision Description
1	HG	28-09-2015	Revision changed to numeric



HG

**HEDENSTED
GRUPPEN**

Vejlevej 15, DK-8722

Hedensted

Tel. (+45) 75 89 12 44

Fax (+45) 75 89 11 80

www.hedensted-aruppen.dk

HG – for professional fur farmers