



BRUGERMANUAL



**HG Super Skub
Hydra Combi
med aflivningskasse**

1. Indholdsfortegnelse.

1. Indholdsfortegnelse.	2
2. Introduktion.	3
2.1 Garanti.	3
3. Advarsel.	3
3.1 Piktogram forklaring.	4
4. Betjeningsvejledning.	5
4.1 Start maskinen.	5
4.2 Aflivning af mink:	5
4.3 Fremdrift og tip.	7
5. Forholdsregler.	8
6. Vedligeholdelse.	8
7. FAQ.	9
8. Tekniske data.	10
9. Rengøring.	12
10. Hondas motorvejledning.	12
11. Overensstemmelseserklæring.	13
12. Reservedele.	14

2. Introduktion.

HG S.S. Hydra Combi er baseret på en motordrevet enhed med hydraulisk fremdrift. HG S.S. Hydra Combi monteret med aflivningskasse, er kun beregnet til aflivning af mink. Brugermanualen bør gennemlæses grundigt før maskinen tages i brug. Maskinens pålidelighed og funktionalitet afhænger af korrekt brug.

2.1 Garanti.

Der ydes 1 års garanti på HG S.S Hydra Combi. Defekte dele ombyttes, hvis fejlen kan henføres til fabrikationsfejl, fejl som kan henføres til fragt er ikke omfattet af denne garanti. I tilfælde af fejlbetjening af HG HG S.S Hydra Combi , ydes der ingen garanti hverken på maskine eller beskadigede skind. Ved ombygning og brug af uoriginale dele bortfalder garantien.

3. Advarsel.

Læs denne betjeningsvejledning grundigt igennem inden ibrugtagelse.

Maskinen afliver minkene med udstødningsgas og må derfor kun bruges udendørs. Det er til enhver tid operatørens ansvar at minkene aflives på forsvarlig vis.

Undgå at berøre udstødningskomponenterne efter start af maskinen. Det frarådes på det kraftigste at arbejde eller berøre området under kassen før maskinen er helt afkølet og tip sikringen er i aflåst position.

3.1 Piktogram forklaring.



Brandfarlig væske:
Undgå åben ild og rygning.



Varme emner:
Undgå berøring, fare for brandsår.



Udstødningsgas:
Brug evt. åndedrætsværn.

Udstødningsgas
Undgå indånding

4. Betjeningsvejledning.

4.1 Start maskinen.

HG S.S. Hydra Combi startes ved først at give fuld choker og gas. Drej nøglen om på start eller træk i rekyl starteren (start snoren). Chokeren returneres helt tilbage og gassen reguleres til det ønskede niveau.

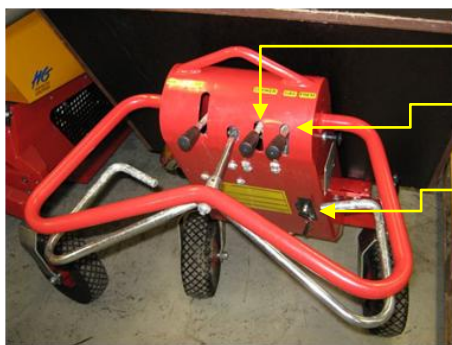

Choker

Gas

Nøgle start

4.2 Aflivning af mink:

Før minkene kommer i aflivningskassen trækkes knappen på siden af styrepulten ud, minkene kommer i kassen.

Når motoren begynder at gå ujævnt trykkes knappen ind igen.

Husk dagligt at rengøre udstødningsfilteret. Filterkassen tømmes for kondenseret vand efter behov.

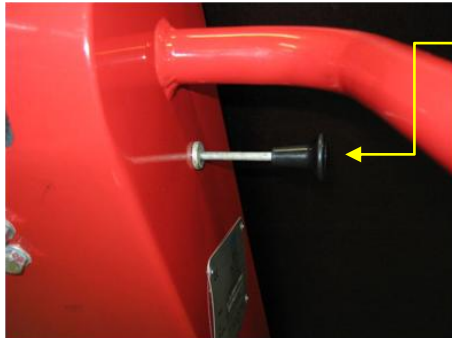

Kabeltræk for aflivningsspjæld

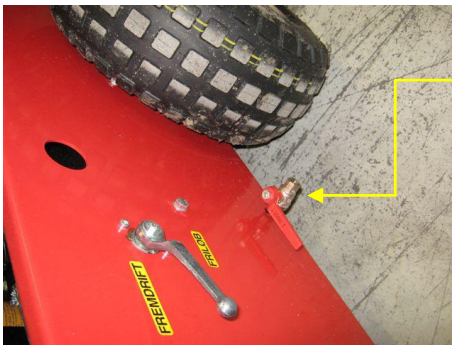

**Hane for aftapning af kondens i
udstødningsfilteret**

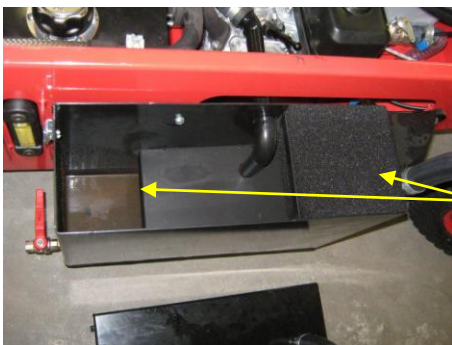

**Afmonter låget på filterkassen tag
filteret ud rengør med varmt vand
Fyld evt. med vand til kant**



**Ønskes finere filtrering brug evt.
bomuldsklud uden på filteret**

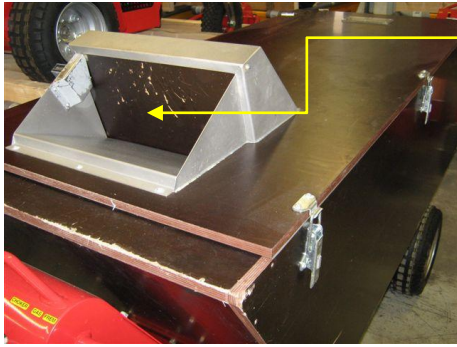

Kom mink i kassen via lemmen.



Tjek at minkene er døde.
Åben snap låsene og tip
minkene ud.

4.3 Fremdrift og tip.

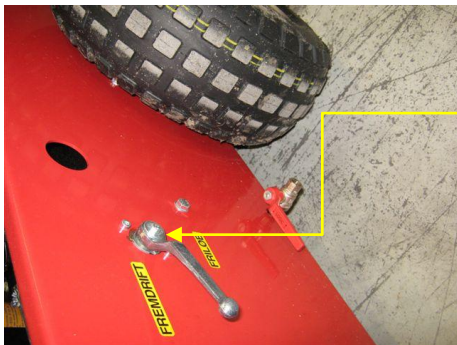

Fritstilleren gør det muligt at
skubbe maskinen manuelt ved
at dreje denne mod friløb.



Tip håndtag

Butterfly håndtag aktiveres for
fremdrift og bak

5. Forholdsregler.

- Undersøg dagligt at oliestanden er korrekt på motoren.
- Brug altid den foreskrevne type motorolie SAE 10W-30.
- Anvend altid ren brændstof oktan 92 blyfri el. højere.
- Ved brug mellem -2 og 7 grader brug evt. karburatorsprit.
- Vedligehold aldrig maskinen under drift.
- Det anbefales at Hedensted Gruppen udfører et årligt eftersyn.

6. Vedligeholdelse.

DAGLIG	1) Kontrol af oliestanden på motoren.	
	2) Kontrol af luftfilter/skift filter	
	3) Vedr. punkt 1 og 2 se MOTORVEJLEDNING.	
	Check hydraulikoliestand. Ved hvid baggrund er der for lidt olie.	13 liter
	HUSK at sænke ladet efter brug.	
	Smørring af baghjul (smørenipler)	fedt
EFTER 20 TIMERS KØRSEL	Udskiftning af motorolie første gang	SAE 10W-30 0,6 liter
EFTER 50 TIMERS KØRSEL ÅRLIGT	Hydraulikfilter skiftes første gang efter 50 timer, derefter årligt. Desuden når indikatoren er i det røde område.	

EFTER 50 TIMERS KØRSEL ÅRLIGT/2000 TIMER	Hydraulikolie skiftes første gang efter 50 timer, derefter ved 2000 timer eller mindst én gang årligt.	Type: Handel 32 13 liter
FOR HVER 200 KØRETIMER	Rengøring og justering af tændrør bør foretages. SE IØVRINGT MOTORVEJLEDNING.	

7. FAQ.

Fejl/Problem	Mulig årsag	Løsning
Motoren starter ikke.	<ol style="list-style-type: none">1. Ingen benzin på.2. Batteriet er afladet.3. Choker og el. gas er ikke indstillet korrekt.4. Sikring i startmodul er slået ud,	<ol style="list-style-type: none">1. Fyld tanken med blyfri benzin oktan 92.2. Batteriet lades op med 12V lader.3. Tjek der er givet fuld gas og choker. Er motoren varm fjernes chokeren.4. Tryk sikringsknappen ind sidder under nøglen.
Ladet vil ikke tippe.	<ol style="list-style-type: none">1. Hydrauliksystemet mangler olie.	<ol style="list-style-type: none">1. Påfyld hydraulikolie tjek niveau glasset på siden af maskinen.
Minkene dør ikke.	<ol style="list-style-type: none">1. Kassen er utæt ved låger.2. Aflivningsknappen bruges ikke.3. Udstødningssystemet er utæt.	<ol style="list-style-type: none">1. Tjek alle snaplåse er lukket.2. Træk aflivningsknappen ud sidder på højre side af styrekonsollen.3. Tjek udstødningssystemet for utæthed.

Døgnservice 20 21 30 44

Motoren starter men maskinen vil ikke køre.	1. Hydrauliksystemet mangler olie. 2. Frikoblingshåndtaget står forkert.	1. Påfyld hydraulikolie tjek niveau glasset på siden af maskinen. 2. Drej Frikoblingshåndtaget om på fremdrift.
Motoren går ud efter kort tids brug og er svær at starte.	1. Der opstår is i karburatoren.	1. Anvend karburatorsprit i benzinen.

8. Tekniske data.

Mål og vægt:

Bredde:	86cm
Længde:	234cm
Højde:	129 cm
Egenvægt:	290kg
Vendediameter: (udvendig dia.)	200cm

Motor:

Type:	Honda GX 200
Effekt kW / HK:	4,9 / 6,5
Omdrejninger:	3600 o/min
Oliemængde:	0,6 ltr.
Hydraulikoliemængde:	13 ltr.

Væsketyper:

Motorolie:	Q8 T520 SAE 15W-30
Hydraulikolie:	Q8 ISO VG68
Brændstof:	Benzin

Tank og beholdere:

Hedensted Gruppen – til professionelle pelsdyravlere

Døgnservice 20 21 30 44

Hydrauliktank:	12 ltr.
Brændstoftank:	3,6 ltr.
Aflivningskasse	700 ltr.

Hjuldimensioner:

Forhjul: LP-190-8

Baghjul: 400-4"

9. Rengøring.

Rengør med højtryksrenser undgå at sprøjte direkte på elektriske komponenter. Brug efterfølgende desinfektionsmiddel.

10. Hondas motorvejledning.

INTRODUCTION

Thank you for purchasing a Honda engine. We want to help you to get the best results from your new engine and to operate it safely. This manual contains information on how to do that; please read it carefully before operating the engine. If a problem should arise, or if you have any questions about your engine, consult an authorized Honda servicing dealer.

All information in this publication is based on the latest product information available at the time of printing. Honda Motor Co., Ltd. reserves the right to make changes at any time without notice and without incurring any obligation. No part of this publication may be reproduced without written permission.

This manual should be considered a permanent part of the engine and should remain with the engine if resold.

Review the instructions provided with the equipment powered by this engine for any additional information regarding engine startup, shutdown, operation, adjustments or any special maintenance instructions.



United States, Puerto Rico, and U.S. Virgin Islands:
We suggest you read the warranty policy to fully understand its coverage and your responsibilities of ownership. The warranty policy is a separate document that should have been given to you by your dealer.

SAFETY MESSAGES

Your safety and the safety of others are very important. We have provided important safety messages in this manual and on the engine. Please read these messages carefully.

A safety message alerts you to potential hazards that could hurt you or others. Each safety message is preceded by a safety alert symbol  and one of three words, DANGER, WARNING, or CAUTION.

These signal words mean:

 DANGER	You WILL be KILLED or SERIOUSLY HURT if you don't follow instructions.
 WARNING	You CAN be KILLED or SERIOUSLY HURT if you don't follow instructions.
 CAUTION	You CAN be HURT if you don't follow instructions.

Each message tells you what the hazard is, what can happen, and what you can do to avoid or reduce injury.

DAMAGE PREVENTION MESSAGES

You will also see other important messages that are preceded by the word NOTICE.

This word means:

NOTICE	Your engine or other property can be damaged if you don't follow instructions.
---------------	--

The purpose of these messages is to help prevent damage to your engine, other property, or the environment.

© 2005 Honda Motor Co., Ltd. — All Rights Reserved

GX120U1-GX160U1-GX200U

37Z4F603
00X37-24F-6030

HONDA

OWNER'S MANUAL MANUEL DE L'UTILISATEUR MANUAL DEL PROPIETARIO

GX120 · GX160 · GX200

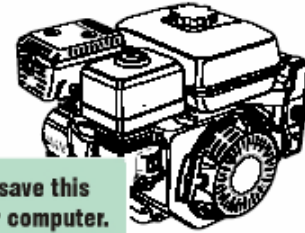

Click here to save this manual to your computer.



WARNING:

The engine exhaust from this product contains chemicals known to the State of California to cause cancer, birth defects or other reproductive harm.

CONTENTS

INTRODUCTION.....1	SEDIMENT CUP.....12
SAFETY MESSAGES.....1	SPARK PLUG.....12
SAFETY INFORMATION.....2	SPARK ARRESTER.....13
SAFETY LABEL LOCATION.....2	IDLE SPEED.....13
COMPONENT & CONTROL LOCATION.....2	HELPFUL TIPS & SUGGESTIONS.....13
FEATURES.....3	STORING YOUR ENGINE.....13
BEFORE OPERATION	TRANSPORTING.....14
CHECKS.....3	TAKING CARE OF UNEXPECTED PROBLEMS.....15
OPERATION.....4	FUSE REPLACEMENT.....15
SAFE OPERATING PRECAUTIONS.....4	TECHNICAL & CONSUMER INFORMATION.....16
STARTING THE ENGINE.....4	Serial Number Location.....16
STOPPING THE ENGINE.....5	Battery Connections for Electric Starter.....16
SETTING ENGINE SPEED.....6	Remote Control Linkage.....16
SERVICING YOUR ENGINE.....7	Carburetor Modifications for High Altitude Operation.....16
THE IMPORTANCE OF MAINTENANCE.....7	Safety Precautions.....17
MAINTENANCE SAFETY.....7	Emission Control System Information.....17
SAFETY PRECAUTIONS.....7	Air Index.....18
MAINTENANCE SCHEDULE.....7	Specifications.....18
REFUELING.....8	Tuneup Specifications.....18
ENGINE OIL.....8	Quick Reference Information.....19
Recommended Oil.....8	Wiring Diagrams.....19
Oil Level Check.....9	CONSUMER INFORMATION.....20
Oil Change.....9	Distributor/Dealer Locator Information.....20
REDUCTION CASE OIL.....9	Customer Service Information.....20
Recommended Oil.....9	
Oil Level Check.....9	
Oil Change.....10	
AIR CLEANER.....10	
Inspection.....10	
Cleaning.....11	

ENGLISH

FRANÇAIS

ESPAÑOL

SAFETY INFORMATION

- Understand the operation of all controls and learn how to stop the engine quickly in case of emergency. Make sure the operator receives adequate instruction before operating the equipment.
- Do not allow children to operate the engine. Keep children and pets away from the area of operation.
- Your engine's exhaust contains poisonous carbon monoxide. Do not run the engine without adequate ventilation, and never run the engine indoors.
- The engine and exhaust become very hot during operation. Keep the engine at least 1 meter (3 feet) away from buildings and other equipment during operation. Keep flammable materials away, and do not place anything on the engine while it is running.

SAFETY LABEL LOCATION

This label warns you of potential hazards that can cause serious injury. Read it carefully. If the label comes off or becomes hard to read, contact your Honda dealer for replacement.



For Canadian types only:
French label comes with the engine.

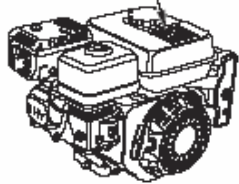

Gasoline is highly flammable and explosive. Turn engine off and let cool before refueling.



The engine emits toxic poisonous carbon monoxide gas. Do not run in an enclosed area.



Read Owner's Manual before operation.

COMPONENT & CONTROL LOCATION

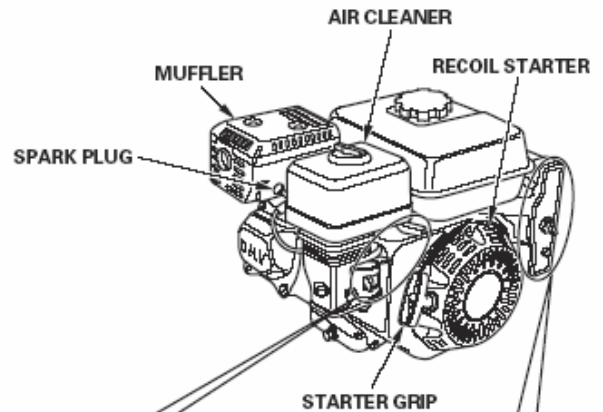
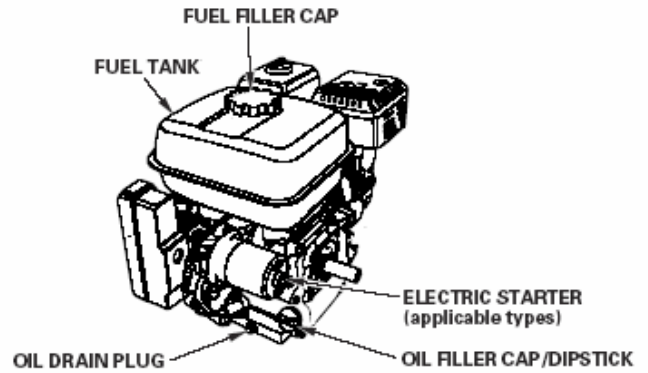

ENGINE CONTROL TYPES

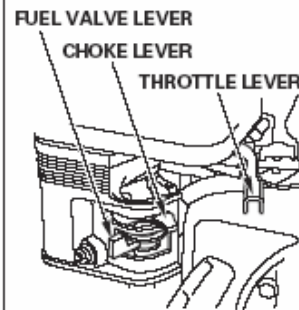

CHOKE LEVER (air cleaner low profile type)

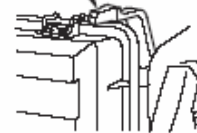

EXCEPT ELECTRIC STARTER TYPES

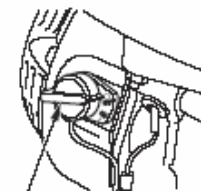

ENGINE SWITCH

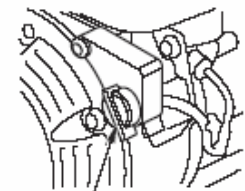

ENGINE SWITCH ELECTRIC STARTER TYPES

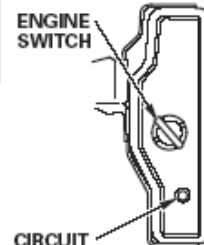

CIRCUIT PROTECTOR

FEATURES

OIL ALERT® SYSTEM (applicable types)

The Oil Alert® system is designed to prevent engine damage caused by an insufficient amount of oil in the crankcase. Before the oil level in the crankcase can fall below a safe limit, the Oil Alert® system will automatically stop the engine (the engine switch will remain in the ON position).

If the engine stops and will not restart, check the engine oil level (see page 9) before troubleshooting in other areas.

CIRCUIT PROTECTOR (applicable types)

The circuit protector protects the battery charging circuit. A short circuit, or a battery connected with reverse polarity, will trip the circuit protector.

The green indicator inside the circuit protector will pop out to show that the circuit protector has switched off. If this occurs, determine the cause of the problem, and correct it before resetting the circuit protector.

Push the circuit protector button to reset.

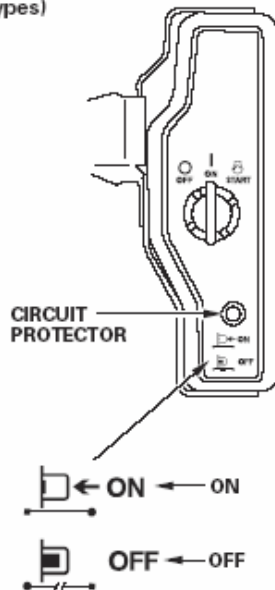

BEFORE OPERATION CHECKS

IS YOUR ENGINE READY TO GO?

For your safety, and to maximize the service life of your equipment, it is very important to take a few moments before you operate the engine to check its condition. Be sure to take care of any problem you find, or have your servicing dealer correct it, before you operate the engine.

⚠ WARNING

Improperly maintaining this engine, or failure to correct a problem before operation, can cause a malfunction in which you can be seriously hurt or killed.

Always perform a preoperation inspection before each operation, and correct any problem.

Before beginning your preoperation checks, be sure the engine is level and the engine switch is in the OFF position.

Always check the following items before you start the engine:

Check the General Condition of the Engine

1. Look around and underneath the engine for signs of oil or gasoline leaks.
2. Remove any excessive dirt or debris, especially around the muffler and recoil starter.
3. Look for signs of damage.
4. Check that all shields and covers are in place, and all nuts, bolts, and screws are tightened.

Check the Engine

1. Check the fuel level (see page 8). Starting with a full tank will help to eliminate or reduce operating interruptions for refueling.
2. Check the engine oil level (see page 9). Running the engine with a low oil level can cause engine damage.

The Oil Alert® system (applicable types) will automatically stop the engine before the oil level falls below safe limits. However, to avoid the inconvenience of an unexpected shutdown, always check the engine oil level before startup.

3. Check the reduction case oil level on applicable types (see page 9). Oil is essential to reduction case operation and long life.
4. Check the air filter element (see page 10). A dirty air filter element will restrict air flow to the carburetor, reducing engine performance.
5. Check the equipment powered by this engine.

Review the instructions provided with the equipment powered by this engine for any precautions and procedures that should be followed before engine startup.

OPERATION

SAFE OPERATING PRECAUTIONS

Before operating the engine for the first time, please review the *SAFETY INFORMATION* section on page 2 and the *BEFORE OPERATION CHECKS* on page 3.

⚠ WARNING

Carbon monoxide gas is toxic. Breathing it can cause unconsciousness and even kill you.

Avoid any areas or actions that expose you to carbon monoxide.

Review the instructions provided with the equipment powered by this engine for any safety precautions that should be observed with engine startup, shutdown or operation.

STARTING THE ENGINE

1. Move the fuel valve lever to the ON position.

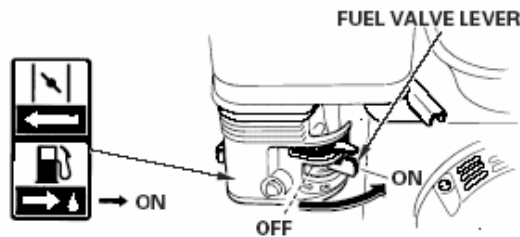

2. To start a cold engine, move the choke lever to the CLOSED position.

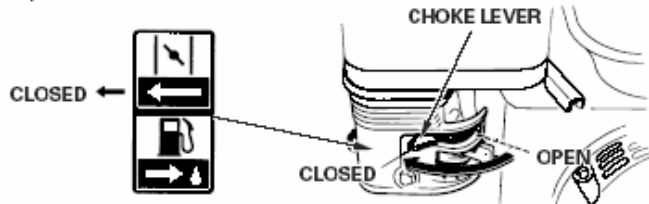

To restart a warm engine, leave the choke lever in the OPEN position.

Some engine applications use a remote-mounted choke control rather than the engine-mounted choke lever shown here. Refer to the instructions provided by the equipment manufacturer.

3. Move the throttle lever away from the MIN. position, about 1/3 of the way toward the MAX. position.

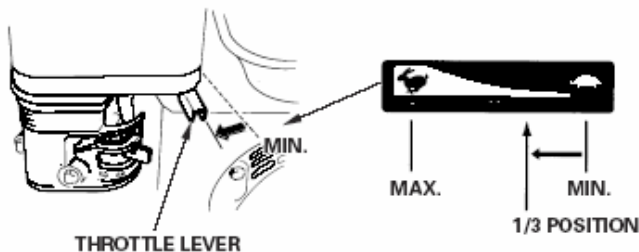

Some engine applications use a remote-mounted throttle control rather than the engine-mounted throttle lever shown here. Refer to the instructions provided by the equipment manufacturer.

4. Turn the engine switch to the ON position.

EXCEPT ELECTRIC STARTER TYPES

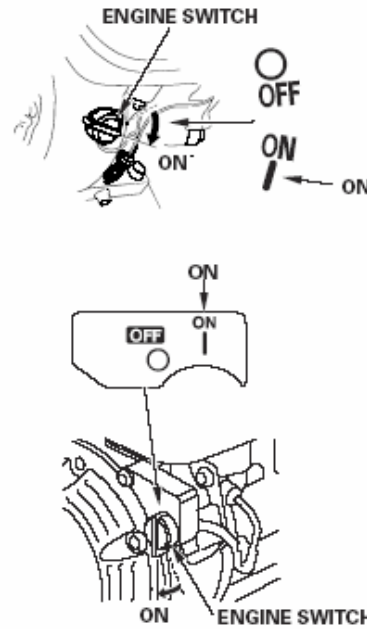

ELECTRIC STARTER TYPES

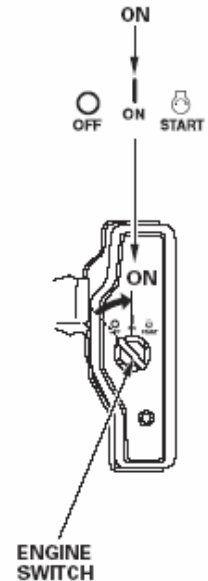

5. Operate the starter.

RECOIL STARTER:

Pull the starter grip lightly until you feel resistance, then pull briskly. Return the starter grip gently.

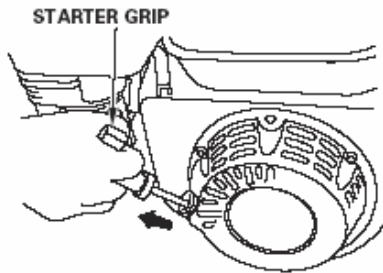

NOTICE

Do not allow the starter grip to snap back against the engine. Return it gently to prevent damage to the starter.

ELECTRIC STARTER (applicable types):

Turn the key to the START position, and hold it there until the engine starts.

If the engine fails to start within 5 seconds, release the key, and wait at least 10 seconds before operating the starter again.

NOTICE

Using the electric starter for more than 5 seconds at a time will overheat the starter motor and can damage it.

When the engine starts, release the key, allowing it to return to the ON position.

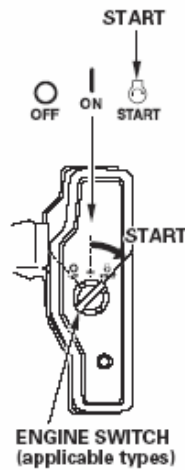

6. If the choke lever has been moved to the CLOSED position to start the engine, gradually move it to the OPEN position as the engine warms up.

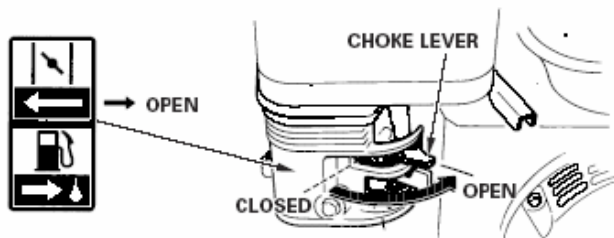

STOPPING THE ENGINE

To stop the engine in an emergency, simply turn the engine switch to the OFF position. Under normal conditions, use the following procedure. Refer to the instructions provided by the equipment manufacturer.

1. Move the throttle lever to the MIN. position.

Some engine applications use a remote-mounted throttle control rather than the engine-mounted throttle lever shown here.



2. Turn the engine switch to the OFF position.

EXCEPT ELECTRIC STARTER TYPES

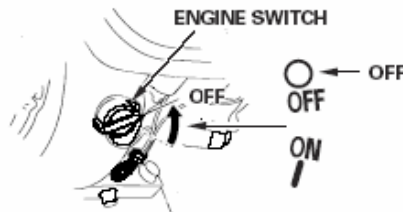

ELECTRIC STARTER TYPES

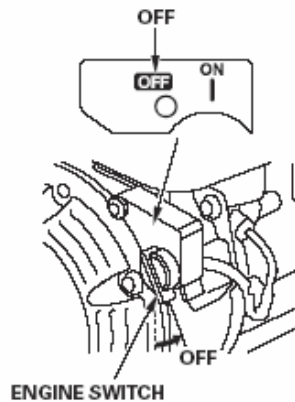
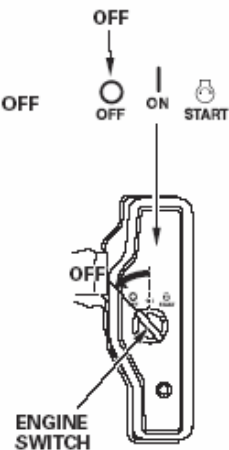

3. Turn the fuel valve lever to the OFF position.

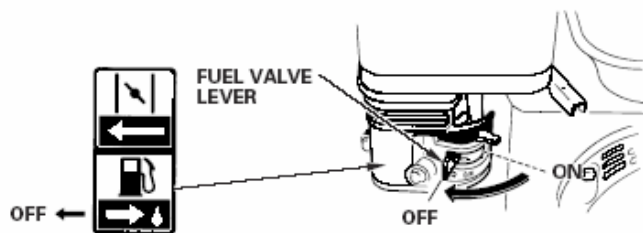

SETTING ENGINE SPEED

Position the throttle lever for the desired engine speed.

Some engine applications use a remote-mounted throttle control rather than the engine-mounted throttle lever shown here. Refer to the instructions provided by the equipment manufacturer.

For engine speed recommendations, refer to the instructions provided with the equipment powered by this engine.

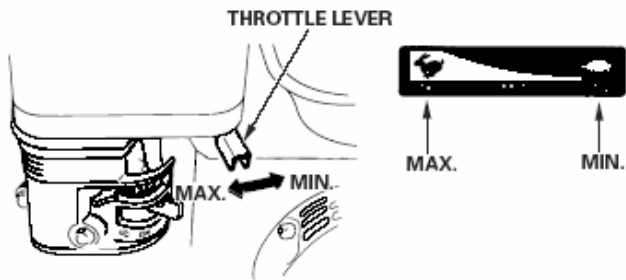

SERVICING YOUR ENGINE

THE IMPORTANCE OF MAINTENANCE

Good maintenance is essential for safe, economical and trouble-free operation. It will also help reduce pollution.

⚠ WARNING

Improper maintenance, or failure to correct a problem before operation, can cause a malfunction in which you can be seriously hurt or killed.

Always follow the inspection and maintenance recommendations and schedules in this owner's manual.

To help you properly care for your engine, the following pages include a maintenance schedule, routine inspection procedures, and simple maintenance procedures using basic hand tools. Other service tasks that are more difficult, or require special tools, are best handled by professionals and are normally performed by a Honda technician or other qualified mechanic.

The maintenance schedule applies to normal operating conditions. If you operate your engine under severe conditions, such as sustained high-load or high-temperature operation, or use in unusually wet or dusty conditions, consult your servicing dealer for recommendations applicable to your individual needs and use.

Maintenance, replacement, or repair of the emission control devices and systems may be performed by any engine repair establishment or individual, using parts that are "certified" to EPA standards.

MAINTENANCE SAFETY

Some of the most important safety precautions follow. However, we cannot warn you of every conceivable hazard that can arise in performing maintenance. Only you can decide whether or not you should perform a given task.

⚠ WARNING

Failure to properly follow maintenance instructions and precautions can cause you to be seriously hurt or killed.

Always follow the procedures and precautions in this owner's manual.

SAFETY PRECAUTIONS

- Make sure the engine is off before you begin any maintenance or repairs. This will eliminate several potential hazards:
 - **Carbon monoxide poisoning from engine exhaust.**
Be sure there is adequate ventilation whenever you operate the engine.
 - **Burns from hot parts.**
Let the engine and exhaust system cool before touching.
 - **Injury from moving parts.**
Do not run the engine unless instructed to do so.
- Read the instructions before you begin, and make sure you have the tools and skills required.
- To reduce the possibility of fire or explosion, be careful when working around gasoline. Use only a nonflammable solvent, not gasoline, to clean parts. Keep cigarettes, sparks and flames away from all fuel related parts.

Remember that an authorized Honda servicing dealer knows your engine best and is fully equipped to maintain and repair it. To ensure the best quality and reliability, use only new genuine Honda parts or their equivalents for repair and replacement.

MAINTENANCE SCHEDULE

REGULAR SERVICE PERIOD (3) Perform at every indicated month or operating hour interval, whichever comes first.		Each Use	First Month or 20Hrs	Every 3 Months or 50 Hrs	Every 6 Months or 100 Hrs	Every Year or 300 Hrs	Refer to Page	
ITEM								
Engine oil	Check level	○					9	
	Change		○		○		9	
Reduction case oil (applicable types)	Check level	○					9 – 10	
	Change		○		○		10	
Air filter	Check	○					10	
	Clean			○ (1)	○ *(1)		11 – 12	
	Replace					○ **		
Sediment cup	Clean				○		12	
Spark plug	Check-adjust				○		12	
	Replace					○		
Spark arrester (applicable types)	Clean				○		13	
Idle speed	Check-adjust					○ (2)	13	
Valve clearance	Check-adjust					○ (2)	Shop manual	
Combustion chamber	Clean	After every 500 Hrs. (2)						Shop manual
Fuel tank & filter	Clean				○ (2)		Shop manual	
Fuel tube	Check	Every 2 years (Replace if necessary) (2)						Shop manual

- * • Internal vent carburetor with dual element type only.
- Cyclone type every 6 months or 150 hours.

INTERNAL VENT CARBURETOR TYPE

BREATHING TUBE

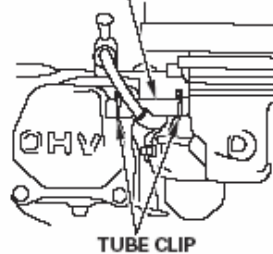

TUBE CLIP

STANDARD TYPE

BREATHING TUBE

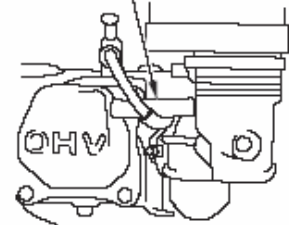

- ** • Replace paper element type only.
- Cyclone type every 2 years or 600 hours.

- (1) Service more frequently when used in dusty areas.
- (2) These items should be serviced by your servicing dealer, unless you have the proper tools and are mechanically proficient. Refer to Honda shop manual for service procedures.
- (3) For commercial use, log hours of operation to determine proper maintenance intervals.

Failure to follow this maintenance schedule could result in non-warrantable failures.

REFUELING

Recommended Fuel

Unleaded gasoline	
U.S.	Pump octane rating 86 or higher
Except U.S.	Research octane rating 91 or higher
	Pump octane rating 86 or higher

This engine is certified to operate on unleaded gasoline. Unleaded gasoline produces fewer engine and spark plug deposits and extends exhaust system life.

⚠ WARNING

Gasoline is highly flammable and explosive, and you can be burned or seriously injured when refueling.

- Stop engine and keep heat, sparks, and flame away.
- Refuel only outdoors.
- Wipe up spills immediately.

NOTICE

Fuel can damage paint and some types of plastic. Be careful not to spill fuel when filling your fuel tank. Damage caused by spilled fuel is not covered under the Distributor's Limited Warranty.

Never use stale or contaminated gasoline or oil/gasoline mixture. Avoid getting dirt or water in the fuel tank.

Occasionally you may hear a light "spark knock" or "pinging" (metallic rapping noise) while operating under heavy loads. This is no cause for concern.

If spark knock or pinging occurs at a steady engine speed, under normal load, change brands of gasoline. If spark knock or pinging persists, see an authorized Honda servicing dealer.

NOTICE

Running the engine with persistent spark knock or pinging can cause engine damage.

Running the engine with persistent spark knock or pinging is considered misuse, and the Distributor's Limited Warranty does not cover parts damaged by misuse.

1. With the engine stopped and on a level surface, remove the fuel tank cap and check the fuel level. Refill the tank if the fuel level is low.
2. Add fuel to the bottom of the fuel level limit of the fuel tank. Do not overfill. Wipe up spilled fuel before starting the engine.

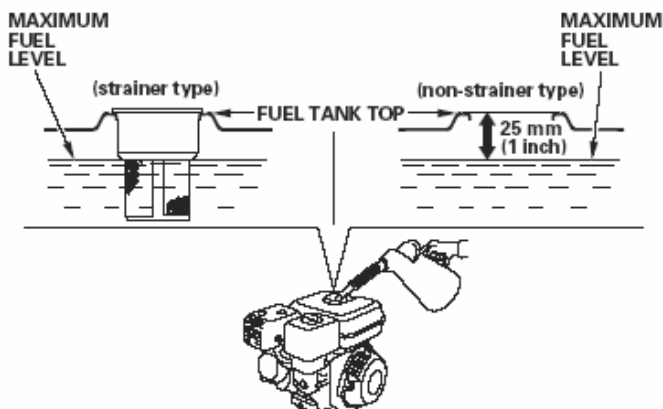

Refuel in a well-ventilated area before starting the engine. If the engine has been running, allow it to cool. Refuel carefully to avoid spilling fuel. Do not fill the fuel tank completely. Fill tank to approximately 25 mm (1 inch) below the top of the fuel tank to allow for fuel expansion. It may be necessary to lower the fuel level depending on operating conditions. After refueling, tighten the fuel tank cap securely.

Never refuel the engine inside a building where gasoline fumes may reach flames or sparks. Keep gasoline away from appliance pilot lights, barbecues, electric appliances, power tools, etc.

Spilled fuel is not only a fire hazard, it causes environmental damage. Wipe up spills immediately.

For information regarding oxygenated fuels, please refer to page 17.

ENGINE OIL

Oil is a major factor affecting performance and service life. Use 4-stroke automotive detergent oil.

Recommended Oil

Use 4-stroke motor oil that meets or exceeds the requirements for API service classification SJ, SL, or equivalent. Always check the API service label on the oil container to be sure it includes the letters SJ, SL, or equivalent.

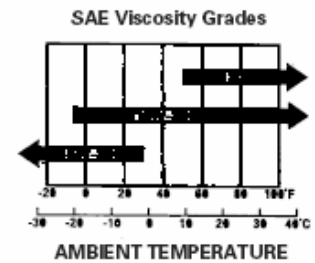

SAE 10W-30 is recommended for general use. Other viscosities shown in the chart may be used when the average temperature in your area is within the indicated range.

Oil Level Check

Check the engine oil level with the engine stopped and in a level position.

1. Remove the oil filler cap/dipstick and wipe it clean.
2. Insert the oil filler cap/dipstick into the oil filler neck as shown, but do not screw it in, then remove it to check the oil level.
3. If the oil level is near or below the lower limit mark on the dipstick, fill with the recommended oil (see page 8) to the upper limit mark (bottom edge of the oil fill hole). Do not overfill.
4. Reinstall the oil filler cap/dipstick.

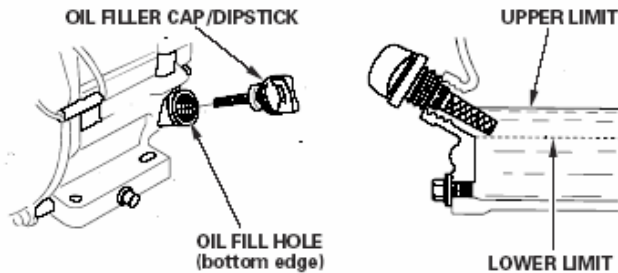

NOTICE

Running the engine with a low oil level can cause engine damage.

The Oil Alert® system (applicable types) will automatically stop the engine before the oil level falls below the safe limit. However, to avoid the inconvenience of an unexpected shutdown, always check the engine oil level before startup.

Oil Change

Drain the used oil when the engine is warm. Warm oil drains quickly and completely.

1. Place a suitable container below the engine to catch the used oil, then remove the oil filler cap/dipstick, oil drain plug and washer.
2. Allow the used oil to drain completely, then reinstall the oil drain plug and new washer, and tighten the oil drain plug securely.

Please dispose of used motor oil in a manner that is compatible with the environment. We suggest you take used oil in a sealed container to your local recycling center or service station for reclamation. Do not throw it in the trash, pour it on the ground, or down a drain.

3. With the engine in a level position, fill to the upper limit mark (bottom edge of the oil fill hole) on the dipstick with the recommended oil (see page 8).

NOTICE

Running the engine with a low oil level can cause engine damage.

The Oil Alert® system (applicable types) will automatically stop the engine before the oil level falls below the safe limit. However, to avoid the inconvenience of an unexpected shutdown, fill to the upper limit, and check the oil level regularly.

4. Install the oil filler cap/dipstick and tighten securely.

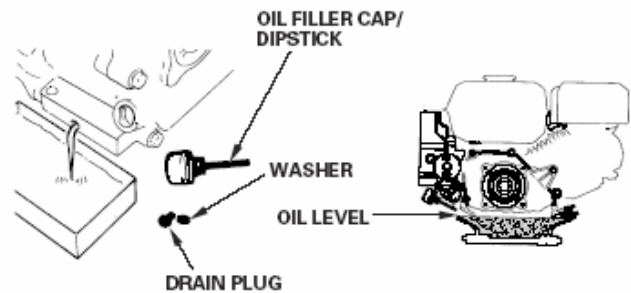

REDUCTION CASE OIL (applicable types)

Recommended Oil

Use the same oil that is recommended for the engine (see page 8).

Oil Level Check

Check the reduction case oil level with the engine stopped and in a level position.

2 : 1 Reduction Case With Centrifugal Clutch

1. Remove the oil filler cap/dipstick and wipe it clean.
2. Insert and remove the oil filler cap/dipstick without screwing it into the filler hole. Check the oil level shown on the oil filler cap/dipstick.
3. If the oil level is low, add oil to reach the upper limit mark on the dipstick with the recommended oil.
4. Screw in the oil filler cap/dipstick and tighten securely.

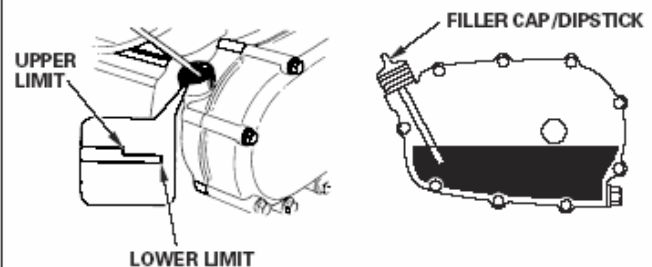

6 : 1 Reduction Case

1. Remove the oil-level-check bolt and washer, and see whether the oil level is at the edge of the bolt hole.
2. If the oil level is below the check bolt hole, remove the filler bolt and washer. Add oil until it starts to flow out the check bolt hole with the recommended oil (see page 9).
3. Install the oil-level-check bolt, filler bolt and washers. Tighten them securely.

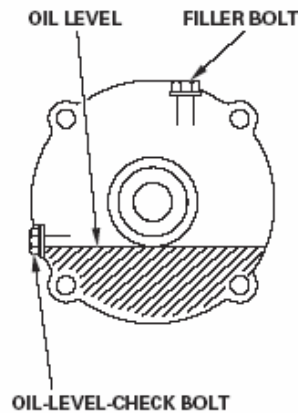

Oil Change

2 : 1 Reduction Case With Centrifugal Clutch

Drain the used oil while the engine is warm. Warm oil drains quickly and completely.

1. Place a suitable container below the reduction case to catch the used oil, then remove the oil filler cap/dipstick, the drain plug and washer.
2. Allow the used oil to drain completely, then reinstall the drain plug and a new washer, and tighten it securely.

Please dispose of used motor oil in a manner that is compatible with the environment. We suggest you take used oil in a sealed container to your local recycling center or service station for reclamation. Do not throw it in the trash or pour it on the ground or down a drain.

3. With the engine in a level position, fill to the upper limit mark on the dipstick with the recommended oil (see page 9). To check the oil level, insert and remove the dipstick without screwing it into the filler hole.

Reduction case oil capacity: 0.50 ℓ (0.53 US qt , 0.44 Imp qt)

NOTICE

Running the engine with a low reduction case oil level can cause reduction case damage.

4. Screw in the filler cap/dipstick securely.

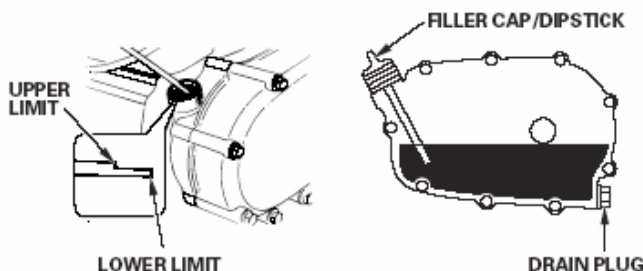

6 : 1 Reduction Case

Drain the used oil while the engine is warm. Warm oil drains quickly and completely.

1. Place a suitable container below the reduction case to catch the used oil, then remove the filler bolt, oil-level-check bolt and washers.
2. Drain the used oil completely into the container by tipping the engine toward the oil-level-check bolt hole.

Please dispose of used motor oil in a manner that is compatible with the environment. We suggest you take used oil in a sealed container to your local recycling center or service station for reclamation. Do not throw it in the trash or pour it on the ground or down a drain.

3. With the engine in a level position, fill oil until it starts to flow out the check bolt hole with the recommended oil (see page 9).

NOTICE

Running the engine with a low reduction case oil level can cause reduction case damage.

4. Reinstall the oil-level-check bolt, filler bolt and new washers, and tighten them securely.

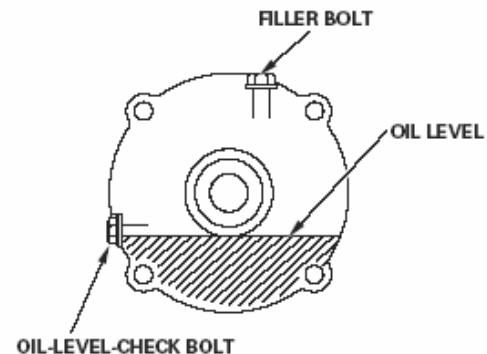

AIR CLEANER

A dirty air cleaner will restrict air flow to the carburetor, reducing engine performance. If you operate the engine in very dusty areas, clean the air filter more often than specified in the MAINTENANCE SCHEDULE.

NOTICE

Operating the engine without an air filter, or with a damaged air filter, will allow dirt to enter the engine, causing rapid engine wear. This type of damage is not covered by the Distributor's Limited Warranty.

Inspection

Remove the air cleaner cover and inspect the filter elements. Clean or replace dirty filter elements. Always replace damaged filter elements. If equipped with an oil-bath air cleaner, also check the oil level.

Refer to pages 11 – 12 for instructions that apply to the air cleaner and filter for your engine type.

Cleaning

Dual-Filter-Element Types

1. Remove the wing nut from the air cleaner cover, and remove the cover.
2. Remove the wing nut from the air filter, and remove the filter.
3. Remove the foam filter from the paper filter.
4. Inspect both air filter elements, and replace them if they are damaged. Always replace the paper air filter element at the scheduled interval (see page 7).

STANDARD DUAL-FILTER-ELEMENT TYPE

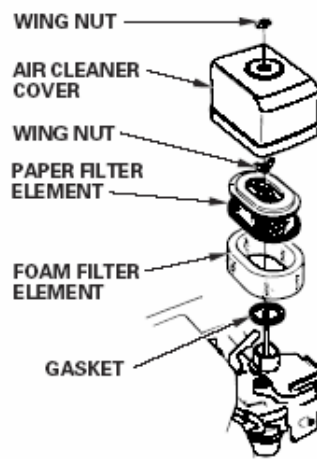

CYCLONE DUAL-FILTER-ELEMENT TYPE

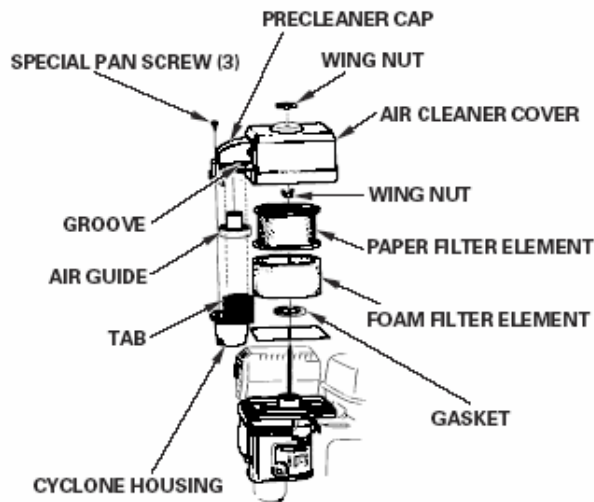

5. Clean the air filter elements if they are to be reused.

Paper air filter element: Tap the filter element several times on a hard surface to remove dirt, or blow compressed air [not exceeding 207 kPa (2.1 kgf/cm², 30 psi)] through the filter element from the inside. Never try to brush off dirt; brushing will force dirt into the fibers.

Foam air filter element: Clean in warm soapy water, rinse, and allow to dry thoroughly. Or clean in nonflammable solvent and allow to dry. Dip the filter element in clean engine oil, then squeeze out all excess oil. The engine will smoke when started if too much oil is left in the foam.

6. **CYCLONE TYPE ONLY:** Remove the three pan-head screws from the precleaner cap, then remove the cyclone housing and air guide. Wash the parts with water, dry them thoroughly, and reassemble them.

Be sure to install the air guide as shown in the illustration.

Install the cyclone housing so the air intake tab fits into the groove in the precleaner cap.

7. Wipe dirt from the inside of the air cleaner case and cover, using a moist rag. Be careful to prevent dirt from entering the air duct that leads to the carburetor.
8. Place the foam air filter element over the paper element, and reinstall the assembled air filter. Be sure the gasket is in place beneath the air filter. Tighten the air filter wing nut securely.
9. Install the air cleaner cover, and tighten the wing nut securely.

Oil-Bath Type

1. Remove the wing nut, and remove the air cleaner cap and cover.
 2. Remove the air filter element from the cover. Wash the cover and filter element in warm soapy water, rinse, and allow to dry thoroughly. Or clean in nonflammable solvent and allow to dry.
 3. Dip the filter element in clean engine oil, then squeeze out all excess oil. The engine will smoke if too much oil is left in the foam.
 4. Empty the used oil from the air cleaner case, wash out any accumulated dirt with nonflammable solvent, and dry the case.
 5. Fill the air cleaner case to the OIL LEVEL mark with the same oil that is recommended for the engine (see page 8).
- Oil capacity: 60 cm³ (2.0 US oz., 2.1 Imp oz)
6. Reassemble the air cleaner, and tighten the wing nut securely.

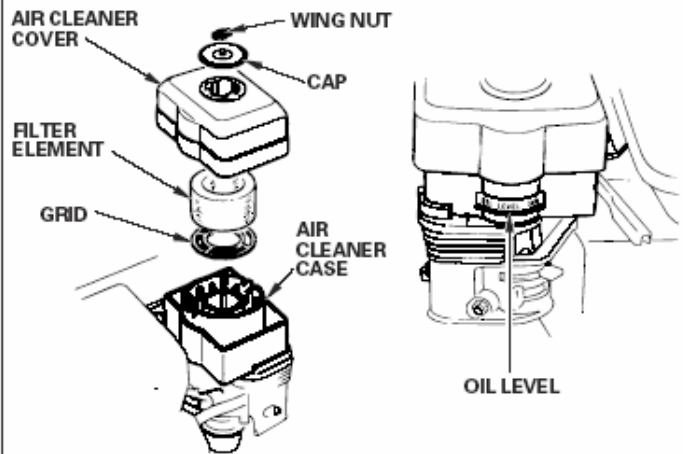

Low Profile Types

1. Unsnap the air cleaner cover clips, remove the air cleaner cover, and remove the air filter element.
2. Wash the element in a solution of household detergent and warm water, then rinse thoroughly, or wash in nonflammable or high flashpoint solvent. Allow the element to dry thoroughly.
3. Soak the air filter element in clean engine oil and squeeze out the excess oil. The engine will smoke during initial startup if too much oil is left in the element.
4. Reinstall the air filter element and the cover.

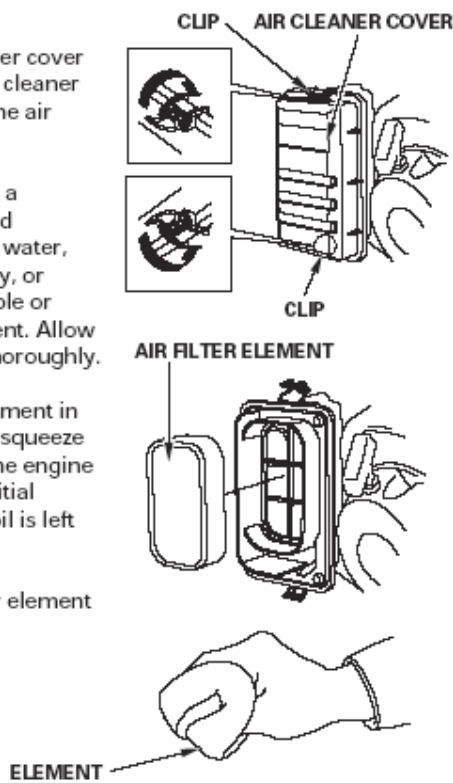

SEDIMENT CUP

Cleaning

⚠ WARNING

Gasoline is highly flammable and explosive, and you can be burned or seriously injured when handling fuel.

- Stop engine and keep heat, sparks, and flame away.
- Handle fuel only outdoors.
- Wipe up spills immediately.

1. Move the fuel valve to the OFF position, then remove the fuel sediment cup and O-ring.
2. Wash the sediment cup and O-ring in nonflammable solvent, and dry them thoroughly.

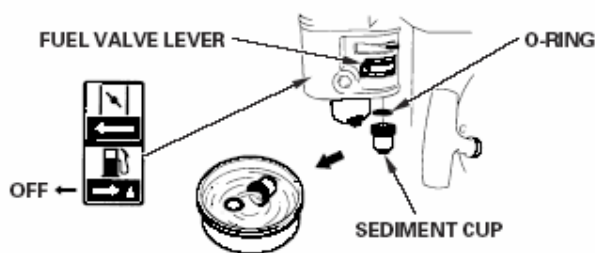

3. Place the O-ring in the fuel valve, and install the sediment cup. Tighten the sediment cup securely.

4. Move the fuel valve to the ON position, and check for leaks. Replace the O-ring if there is any leakage.

SPARK PLUG

Recommended Spark Plugs: BPR6ES (NGK)
W20EPR-U (DENSO)

The recommended spark plug is the correct heat range for normal engine operating temperatures.

NOTICE

An incorrect spark plug can cause engine damage.

For good performance, the spark plug must be properly gapped and free of deposits.

1. Disconnect the spark plug cap, and remove any dirt from around the spark plug area.
2. Remove the spark plug with a 13/16-inch spark plug wrench.
3. Inspect the spark plug. Replace it if damaged, badly fouled, if the sealing washer is in poor condition, or if the electrode is worn.

SPARK PLUG WRENCH

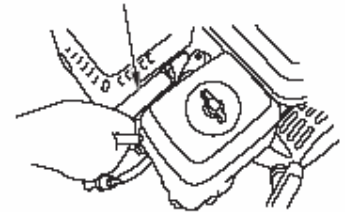

4. Measure the spark plug electrode gap with a wire-type feeler gauge. Correct the gap, if necessary, by carefully bending the side electrode. The gap should be: 0.70–0.80 mm (0.028–0.031 in)

SIDE ELECTRODE

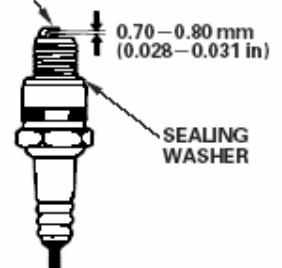

5. Install the spark plug carefully, by hand, to avoid cross-threading.
6. After the spark plug is seated, tighten with a 13/16-inch spark plug wrench to compress the sealing washer.
7. When installing a new spark plug, tighten 1/2 turn after the spark plug seats to compress the washer.
8. When reinstalling the original spark plug, tighten 1/8–1/4 turn after the spark plug seats to compress the washer.

NOTICE

A loose spark plug can overheat and damage the engine. Overtightening the spark plug can damage the threads in the cylinder head.

9. Attach the spark plug cap to the spark plug.

SPARK ARRESTER (applicable types)

The spark arrester may be standard or an optional part, depending on the engine type. In some areas, it is illegal to operate an engine without a spark arrester. Check local laws and regulations. A spark arrester is available from authorized Honda servicing dealers.

The spark arrester must be serviced every 100 hours to keep it functioning as designed.

If the engine has been running, the muffler will be hot. Allow it to cool before servicing the spark arrester.

Spark Arrester Removal

1. Remove the three 4 mm screws from the exhaust deflector, and remove the deflector (applicable types).
2. Remove the four 5 mm screws from the muffler protector and remove the muffler protector.
3. Remove the 4 mm screw from the spark arrester, and remove the spark arrester from the muffler.

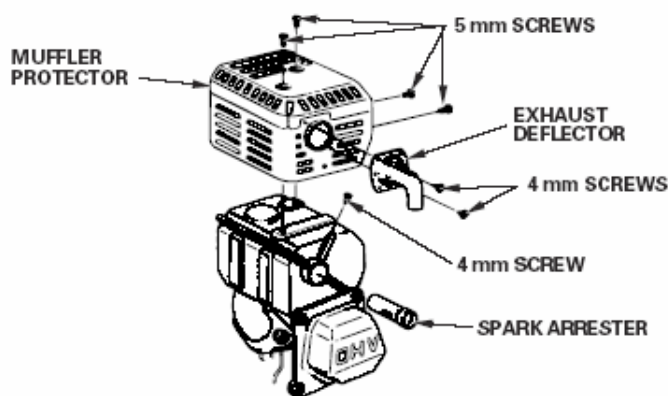

Spark Arrester Cleaning & Inspection

1. Use a brush to remove carbon deposits from the spark arrester screen. Be careful not to damage the screen. Replace the spark arrester if it has breaks or holes.
2. Install the spark arrester, muffler protector, and exhaust deflector in the reverse order of removal.

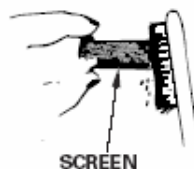

IDLE SPEED

Adjustment

1. Start the engine outdoors, and allow it to warm up to operating temperature.
2. Move the throttle lever to its minimum position.
3. Turn the throttle stop screw to obtain the standard idle speed.

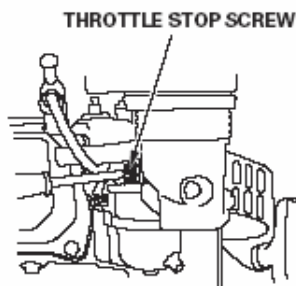

Standard idle speed: 1,400 \pm $\frac{200}{100}$ rpm

HELPFUL TIPS & SUGGESTIONS

STORING YOUR ENGINE

Storage Preparation

Proper storage preparation is essential for keeping your engine trouble-free and looking good. The following steps will help to keep rust and corrosion from impairing your engine's function and appearance, and will make the engine easier to start when you use it again.

Cleaning

If the engine has been running, allow it to cool for at least half an hour before cleaning. Clean all exterior surfaces, touch up any damaged paint, and coat other areas that may rust with a light film of oil.

NOTICE

Using a garden hose or pressure washing equipment can force water into the air cleaner or muffler opening. Water in the air cleaner will soak the air filter, and water that passes through the air filter or muffler can enter the cylinder, causing damage.

Fuel

Gasoline will oxidize and deteriorate in storage. Deteriorated gasoline will cause hard starting, and it leaves gum deposits that clog the fuel system. If the gasoline in your engine deteriorates during storage, you may need to have the carburetor, and other fuel system components, serviced or replaced.

The length of time that gasoline can be left in your fuel tank and carburetor without causing functional problems will vary with such factors as gasoline blend, your storage temperatures, and whether the fuel tank is partially or completely filled. The air in a partially filled fuel tank promotes fuel deterioration. Very warm storage temperatures accelerate fuel deterioration. Fuel problems may occur within a few months, or even less if the gasoline was not fresh when you filled the fuel tank.

Fuel system damage or engine performance problems resulting from neglected storage preparation are not covered under the *Distributor's Limited Warranty*.

You can extend fuel storage life by adding a gasoline stabilizer that is formulated for that purpose, or you can avoid fuel deterioration problems by draining the fuel tank and carburetor.

Adding a Gasoline Stabilizer to Extend Fuel Storage Life

When adding a gasoline stabilizer, fill the fuel tank with fresh gasoline. If only partially filled, air in the tank will promote fuel deterioration during storage. If you keep a container of gasoline for refueling, be sure that it contains only fresh gasoline.

1. Add gasoline stabilizer following the manufacturer's instructions.
2. After adding a gasoline stabilizer, run the engine outdoors for 10 minutes to be sure that treated gasoline has replaced the untreated gasoline in the carburetor.
3. Stop the engine.

Draining the Fuel Tank and Carburetor

⚠ WARNING

Gasoline is highly flammable and explosive, and you can be burned or seriously injured when handling fuel.

- Stop engine and keep heat, sparks, and flame away.
- Handle fuel only outdoors.
- Wipe up spills immediately.

1. Place an approved gasoline container below the carburetor, and use a funnel to avoid spilling fuel.
2. Remove the carburetor drain bolt and gasket. Remove the sediment cup and O-ring, then move the fuel valve lever to the ON position.

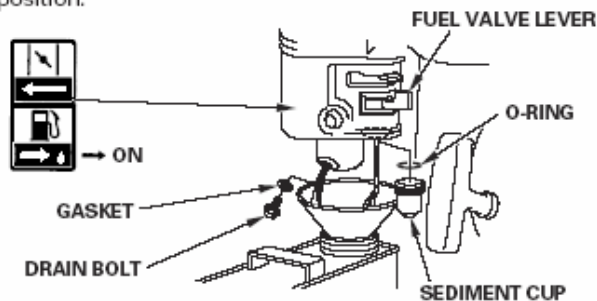

3. After all the fuel has drained into the container, reinstall the drain bolt, gasket, sediment cup and O-ring. Tighten the drain bolt and sediment cup securely.

Engine Oil

1. Change the engine oil (see page 9).
2. Remove the spark plug (see page 12).
3. Pour a tablespoon 5 – 10 cm³ (5 – 10 cc) of clean engine oil into the cylinder.
4. Pull the starter rope several times to distribute the oil in the cylinder.
5. Reinstall the spark plug.
6. Pull the starter rope slowly until resistance is felt and the notch on the starter pulley aligns with the hole at the top of the recoil starter cover. This will close the valves so moisture cannot enter the engine cylinder. Return the starter rope gently.

Align notch on pulley with hole at top of cover.

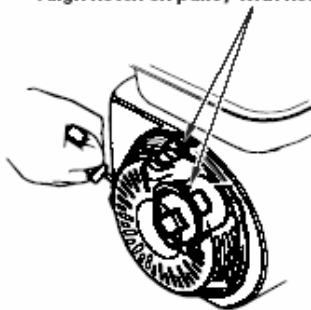

Storage Precautions

If your engine will be stored with gasoline in the fuel tank and carburetor, it is important to reduce the hazard of gasoline vapor ignition. Select a well-ventilated storage area away from any appliance that operates with a flame, such as a furnace, water heater, or clothes dryer. Also avoid any area with a spark-producing electric motor, or where power tools are operated.

If possible, avoid storage areas with high humidity, because that promotes rust and corrosion.

Keep the engine level in storage. Tilting can cause fuel or oil leakage.

With the engine and exhaust system cool, cover the engine to keep out dust. A hot engine and exhaust system can ignite or melt some materials. Do not use sheet plastic as a dust cover. A nonporous cover will trap moisture around the engine, promoting rust and corrosion.

If equipped with a battery for electric starter types, recharge the battery once a month while the engine is in storage. This will help to extend the service life of the battery.

Removal from Storage

Check your engine as described in the *BEFORE OPERATION CHECKS* section of this manual (see page 3).

If the fuel was drained during storage preparation, fill the tank with fresh gasoline. If you keep a container of gasoline for refueling, be sure it contains only fresh gasoline. Gasoline oxidizes and deteriorates over time, causing hard starting.

If the cylinder was coated with oil during storage preparation, the engine will smoke briefly at startup. This is normal.

TRANSPORTING

Keep the engine level when transporting to reduce the possibility of fuel leakage. Turn the fuel valve to the OFF position (see page 5).

TAKING CARE OF UNEXPECTED PROBLEMS

ENGINE WILL NOT START	Possible Cause	Correction
1. Electric starting (applicable types): Check battery and fuse.	Battery discharged.	Recharge battery.
	Fuse burnt out.	Replace fuse (p. 15).
2. Check control positions.	Fuel valve OFF.	Move lever to ON position.
	Choke open.	Move lever to CLOSED position unless the engine is warm.
	Engine switch OFF.	Turn engine switch to ON position.
3. Check engine oil level.	Engine oil level low (Oil Alert models).	Fill with the recommended oil to the proper level (p. 9).
4. Check fuel.	Out of fuel.	Refuel (p. 8).
	Bad fuel; engine stored without treating or draining gasoline, or refueled with bad gasoline.	Drain fuel tank and carburetor (p. 14). Refuel with fresh gasoline (p. 8).
5. Remove and inspect spark plug.	Spark plug faulty, fouled, or improperly gapped.	Gap or replace spark plug (p. 12).
	Spark plug wet with fuel (flooded engine).	Dry and reinstall spark plug. Start engine with throttle lever in MAX. position.
6. Take engine to an authorized Honda servicing dealer, or refer to shop manual.	Fuel filter restricted, carburetor malfunction, ignition malfunction, valves stuck, etc.	Replace or repair faulty components as necessary.

ENGINE LACKS POWER	Possible Cause	Correction
1. Check air filter.	Filter element(s) restricted.	Clean or replace filter element(s) (p. 11–12).
2. Check fuel.	Bad fuel; engine stored without treating or draining gasoline, or refueled with bad gasoline.	Drain fuel tank and carburetor (p. 14). Refuel with fresh gasoline (p. 8).
3. Take engine to an authorized Honda servicing dealer, or refer to shop manual.	Fuel filter restricted, carburetor malfunction, ignition malfunction, valves stuck, etc.	Replace or repair faulty components as necessary.

FUSE REPLACEMENT (applicable types)

The electric starter relay circuit and battery charging circuit are protected by a fuse. If the fuse burns out, the electric starter will not operate. The engine can be started manually if the fuse burns out, but running the engine will not charge the battery.

1. Remove the 6 × 12 mm screw from the rear cover of the engine switch box.
2. Remove the fuse cover, then pull out and inspect the fuse.

If the fuse is burnt out, discard the burnt-out fuse. Install a new fuse with the same rating as the one that was removed, and reinstall the cover.

If you have questions regarding the rating of the original fuse, contact your servicing Honda engine dealer.

NOTICE

Never use a fuse with a rating greater than the one originally equipped with the engine. Serious damage to the electrical system or a fire could result.

3. Reinstall the rear cover. Install the 6 × 12 mm screw and tighten it securely.

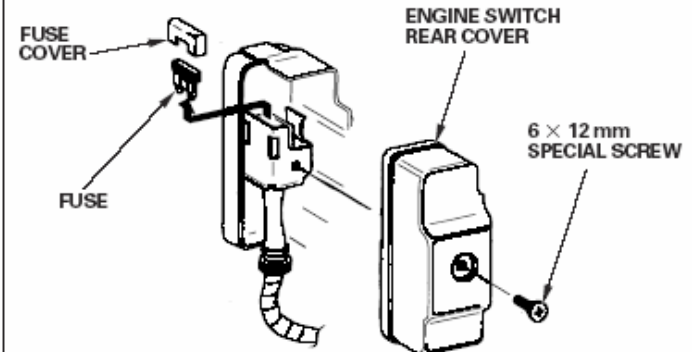

Frequent fuse failure usually indicates a short circuit or an overload in the electrical system. If the fuse burns out frequently, take the engine to a servicing Honda dealer for repair.

TECHNICAL & CONSUMER INFORMATION

TECHNICAL INFORMATION

Serial Number Location

Record the engine serial number, type and purchase date in the space below. You will need this information when ordering parts and when making technical or warranty inquiries.

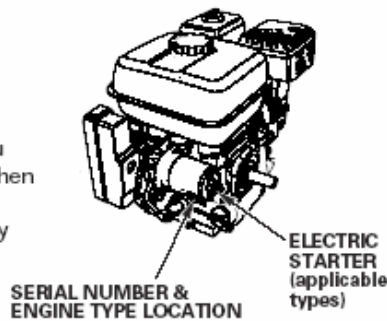

Engine serial number: _____

Engine type: _____

Date Purchased: ____ / ____ / ____

Battery Connections for Electric Starter (applicable types)

Use a 12-volt battery with an ampere-hour rating of at least 18 Ah.

Be careful not to connect the battery in reverse polarity, as this will short circuit the battery charging system. Always connect the positive (+) battery cable to the battery terminal before connecting the negative (-) battery cable, so your tools cannot cause a short circuit if they touch a grounded part while tightening the positive (+) battery cable end.

⚠ WARNING

A battery can explode if you do not follow the correct procedure, seriously injuring anyone nearby.

Keep all sparks, open flames, and smoking materials away from the battery.

1. Connect the battery positive (+) cable to the starter solenoid terminal as shown.
2. Connect the battery negative (-) cable to an engine mounting bolt, frame bolt, or other good engine ground connection.
3. Connect the battery positive (+) cable to the battery positive (+) terminal as shown.
4. Connect the battery negative (-) cable to the battery negative (-) terminal as shown.
5. Coat the terminals and cable ends with grease.

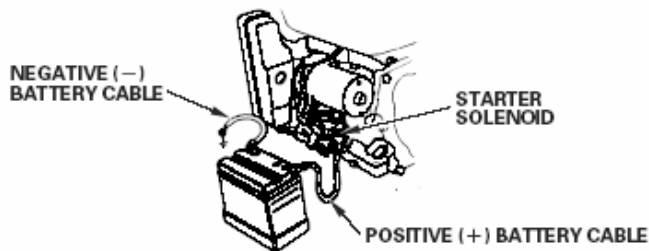

Remote Control Linkage

The throttle and choke control levers are provided with holes for optional cable attachment. The following illustrations show installation examples for a solid wire cable and for a flexible, braided wire cable. If using a flexible, braided wire cable, add a return spring as shown.

It is necessary to loosen the throttle lever friction nut when operating the throttle with a remote-mounted control.

REMOTE THROTTLE LINKAGE

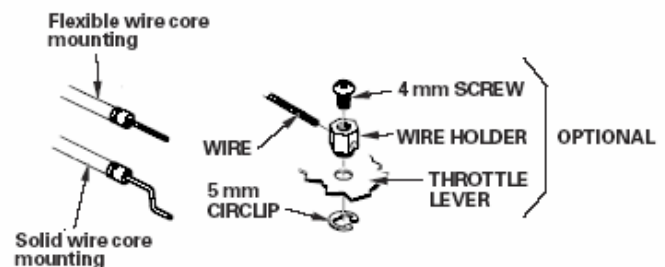
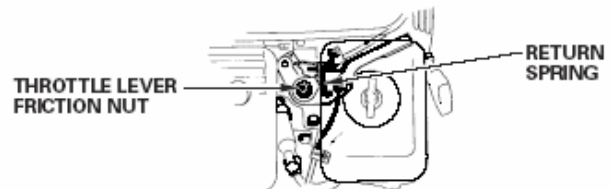

REMOTE CHOKE LINKAGE

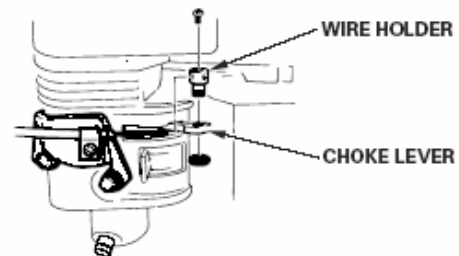

Carburetor Modifications for High Altitude Operation

At high altitude, the standard carburetor air-fuel mixture will be too rich. Performance will decrease, and fuel consumption will increase. A very rich mixture will also foul the spark plug and cause hard starting. Operation at an altitude that differs from that at which this engine was certified, for extended periods of time, may increase emissions.

High altitude performance can be improved by specific modifications to the carburetor. If you always operate your engine at altitudes above 1,500 meters (5,000 feet), have your servicing dealer perform this carburetor modification. This engine, when operated at high altitude with the carburetor modifications for high altitude use, will meet each emission standard throughout its useful life.

Even with carburetor modification, engine horsepower will decrease about 3.5% for each 300-meter (1,000-foot) increase in altitude. The effect of altitude on horsepower will be greater than this if no carburetor modification is made.

NOTICE

When the carburetor has been modified for high altitude operation, the air-fuel mixture will be too lean for low altitude use. Operation at altitudes below 1,500 meters (5,000 feet) with a modified carburetor may cause the engine to overheat and result in serious engine damage. For use at low altitudes, have your servicing dealer return the carburetor to original factory specifications.

Oxygenated Fuels

Some conventional gasolines are being blended with alcohol or an ether compound. These gasolines are collectively referred to as oxygenated fuels. To meet clean air standards, some areas of the United States and Canada use oxygenated fuels to help reduce emissions.

If you use oxygenated fuel, be sure it is unleaded and meets the minimum octane rating requirements.

Before using an oxygenated fuel, try to confirm the fuel's contents. Some states/provinces require this information to be posted on the pump.

The following are the EPA approved percentages of oxygenates:

ETHANOL——— (ethyl or grain alcohol) 10% by volume
You may use gasoline containing up to 10% ethanol by volume. Gasoline containing ethanol may be marketed under the name Gasohol.

MTBE ——— (methyl tertiary butyl ether) 15% by volume
You may use gasoline containing up to 15% MTBE by volume.

METHANOL——— (methyl or wood alcohol) 5% by volume
You may use gasoline containing up to 5% methanol by volume as long as it also contains cosolvents and corrosion inhibitors to protect the fuel system. Gasoline containing more than 5% methanol by volume may cause starting and/or performance problems. It may also damage metal, rubber, and plastic parts of your fuel system.

If you notice any undesirable operating symptoms, try another service station or switch to another brand of gasoline. Fuel system damage or performance problems resulting from the use of an oxygenated fuel containing more than the percentages of oxygenates mentioned above are not covered under the *Distributor's Limited Warranty*.

Emission Control System Information

Source of Emissions

The combustion process produces carbon monoxide, oxides of nitrogen, and hydrocarbons. Control of hydrocarbons and oxides of nitrogen is very important because, under certain conditions, they react to form photochemical smog when subjected to sunlight. Carbon monoxide does not react in the same way, but it is toxic.

Honda utilizes lean carburetor settings and other systems to reduce the emissions of carbon monoxide, oxides of nitrogen, and hydrocarbons.

The U.S., California Clean Air Acts and Environment Canada
EPA, California and Canadian regulations require all manufacturers to furnish written instructions describing the operation and maintenance of emission control systems.

The following instructions and procedures must be followed in order to keep the emissions from your Honda engine within the emission standards.

Tampering and Altering

Tampering with or altering the emission control system may increase emissions beyond the legal limit. Among those acts that constitute tampering are:

- Removal or alteration of any part of the intake, fuel, or exhaust systems.
- Altering or defeating the governor linkage or speed-adjusting mechanism to cause the engine to operate outside its design parameters.

Problems That May Affect Emissions

If you are aware of any of the following symptoms, have your engine inspected and repaired by your servicing dealer.

- Hard starting or stalling after starting.
- Rough idle.
- Misfiring or backfiring under load.
- Afterburning (backfiring).
- Black exhaust smoke or high fuel consumption.

Replacement Parts

The emission control systems on your Honda engine were designed, built, and certified to conform with EPA, California and Canadian emission regulations. We recommend the use of genuine Honda parts whenever you have maintenance done. These original-design replacement parts are manufactured to the same standards as the original parts, so you can be confident of their performance. The use of replacement parts that are not of the original design and quality may impair the effectiveness of your emission control system.

A manufacturer of an aftermarket part assumes the responsibility that the part will not adversely affect emission performance. The manufacturer or rebuilder of the part must certify that use of the part will not result in a failure of the engine to comply with emission regulations.

Maintenance

Follow the maintenance schedule on page 7. Remember that this schedule is based on the assumption that your machine will be used for its designed purpose. Sustained high-load or high-temperature operation, or use in unusually wet or dusty conditions, will require more frequent service.

Air Index

An Air Index Information hang tag/label is applied to engines certified to an emission durability time period in accordance with the requirements of the California Air Resources Board.

The bar graph is intended to provide you, our customer, the ability to compare the emissions performance of available engines. The lower the Air Index, the less pollution.

The durability description is intended to provide you with information relating the engine's emission durability period. The descriptive term indicates the useful life period for the engine's emission control system. See your *Emission Control System Warranty* for additional information.

Descriptive Term	Applicable to Emissions Durability Period
Moderate	50 hours [0–65 cm ³ (0–65 cc)] 125 hours [greater than 65 cm ³ (65 cc)]
Intermediate	125 hours [0–65 cm ³ (0–65 cc)] 250 hours [greater than 65 cm ³ (65 cc)]
Extended	300 hours [0–65 cm ³ (0–65 cc)] 500 hours [greater than 65 cm ³ (65 cc)]

The Air Index Information hang tag/label must remain on the engine until it is sold. Remove the hang tag before operating the engine.

Specifications

GX120 (PTO shaft type S)

Length × Width × Height	297 × 341 × 318 mm (11.7 × 13.4 × 12.5 in)
Dry weight	13.0 kg (28.7 lbs)
Engine type	4-stroke, overhead valve, single cylinder
Displacement [Bore × Stroke]	119 cm ³ (7.3 cu-in) [60 × 42 mm (2.4 × 1.7 in)]
Max. output	2.9 kW (4.0 PS, 4.0 bhp) at 3,600 rpm
Max. torque	7.4 N·m (0.75 kgf·m, 5.4 lbf·ft) at 2,500 rpm
Engine oil capacity	0.60 ℓ (0.63 US qt, 0.53 Imp qt)
Fuel tank capacity	2.5 ℓ (0.66 US gal, 0.55 Imp gal)
Fuel consumption	313 g/kWh (230 g/PSH, 0.51 lb/hph)
Cooling system	Forced air
Ignition system	Transistorized magneto
PTO shaft rotation	Counterclockwise

GX160 (PTO shaft type S)

Length × Width × Height	304 × 362 × 335 mm (12.0 × 14.3 × 13.2 in)
Dry weight	15.0 kg (33.1 lbs)
Engine type	4-stroke, overhead valve, single cylinder
Displacement [Bore × Stroke]	163 cm ³ (9.9 cu-in) [68 × 45 mm (2.7 × 1.8 in)]
Max. output	4.0 kW (5.5 PS, 5.5 bhp) at 3,600 rpm
Max. torque	10.8 N·m (1.1 kgf·m, 8.0 lbf·ft) at 2,500 rpm
Engine oil capacity	0.60 ℓ (0.63 US qt, 0.53 Imp qt)
Fuel tank capacity	3.6 ℓ (0.95 US gal, 0.79 Imp gal)
Fuel consumption	313 g/kWh (230 g/PSH, 0.51 lb/hph)
Cooling system	Forced air
Ignition system	Transistorized magneto
PTO shaft rotation	Counterclockwise

GX200 (PTO shaft type S)

Length × Width × Height	313 × 376 × 335 mm (12.3 × 14.8 × 13.2 in)
Dry weight	16.0 kg (35.3 lbs)
Engine type	4-stroke, overhead valve, single cylinder
Displacement [Bore × Stroke]	196 cm ³ (12.0 cu-in) [68 × 54 mm (2.7 × 2.1 in)]
Max. output	4.8 kW (6.5 PS, 6.5 bhp) at 3,600 rpm
Max. torque	13.2 N·m (1.35 kgf·m, 9.76 lbf·ft) at 2,500 rpm
Engine oil capacity	0.60 ℓ (0.63 US qt, 0.53 Imp qt)
Fuel tank capacity	3.6 ℓ (0.95 US gal, 0.79 Imp gal)
Fuel consumption	313 g/kWh (230 g/PSH, 0.51 lb/hph)
Cooling system	Forced air
Ignition system	Transistorized magneto
PTO shaft rotation	Counterclockwise

Tuneup Specifications GX120/160/200

ITEM	SPECIFICATION	MAINTENANCE
Spark plug gap	0.70–0.80 mm (0.028–0.031 in)	Refer to page: 12
Idle speed	1,400 \pm ₁₀₀ rpm	Refer to page: 13
Valve clearance (cold)	IN: 0.15 ± 0.02 mm EX: 0.20 ± 0.02 mm	See your authorized Honda dealer
Other specifications	No other adjustments needed.	

Quick Reference Information

Fuel	Unleaded gasoline (Refer to page 8)	
	U.S.	Pump octane rating 86 or higher
Engine oil	Except U.S.	Research octane rating 91 or higher
	U.S.	Pump octane rating 86 or higher
Reduction case oil	SAE 10W-30, API SJ or SL, for general use. Refer to page 8.	
Spark plug	Same oil to engine oil, see above (applicable types).	
Maintenance	BPR6ES (NGK) W20EPR-U (DENSO)	
	Before each use: <ul style="list-style-type: none"> • Check engine oil level. Refer to page 9. • Check reduction case oil (applicable types). Refer to page 9 – 10. • Check air filter. Refer to page 10. 	
	First 20 hours: <ul style="list-style-type: none"> • Change engine oil. Refer to page 9. • Change reduction case oil (applicable types). Refer to page 10. 	
	Subsequent: Refer to the maintenance schedule on page 7.	

Wiring Diagrams

With Oil Alert® and Electric Starter

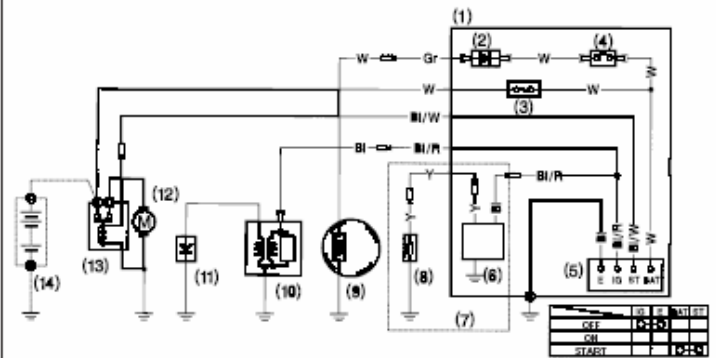

With Oil Alert® and Without Electric Starter

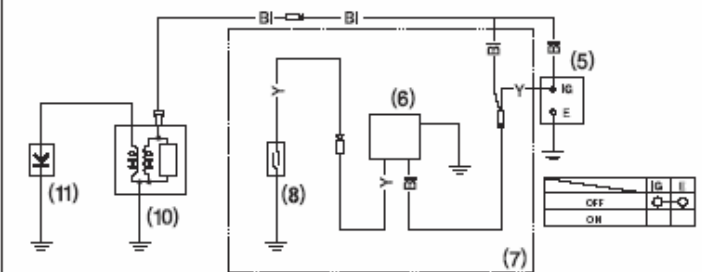

- | | |
|------------------------------|-----------------------|
| (1) CONTROL BOX | (8) OIL LEVEL SWITCH |
| (2) RECTIFIER | (9) CHARGING COIL |
| (3) FUSE | (10) IGNITION COIL |
| (4) CIRCUIT BREAKER | (11) SPARK PLUG |
| (5) ENGINE SWITCH | (12) STARTER MOTOR |
| (6) OIL ALERT UNIT | (13) STARTER SOLENOID |
| (7) Type with Oil Alert unit | (14) BATTERY (12 V) |

Bl	Black	Br	Brown
Y	Yellow	O	Orange
Bu	Blue	Lb	Light blue
G	Green	Lg	Light green
R	Red	P	Pink
W	White	Gr	Gray

CONSUMER INFORMATION

Distributor/Dealer Locator Information

United States, Puerto Rico, and U.S. Virgin Islands:

Visit our website: www.honda-engines.com

Canada:

Call (888) 9HONDA9

or visit our website: www.honda.ca

For European Area:

visit our website: <http://www.honda-engines-eu.com>

Customer Service Information

Servicing dealership personnel are trained professionals. They should be able to answer any question you may have. If you encounter a problem that your dealer does not solve to your satisfaction, please discuss it with the dealership's management. The Service Manager, General Manager, or Owner can help. Almost all problems are solved in this way.

United States, Puerto Rico, and U.S. Virgin Islands:

If you are dissatisfied with the decision made by the dealership's management, contact the Honda Regional Engine Distributor for your area.

If you are still dissatisfied after speaking with the Regional Engine Distributor, you may contact the Honda Office as shown.

All Other Areas:

If you are dissatisfied with the decision made by the dealership's management, contact the Honda Office as shown.

{Honda's Office}

When you write or call, please provide this information:

- Equipment manufacturer's name and model number that the engine is mounted on
- Engine model, serial number, and type (see page 16)
- Name of dealer who sold the engine to you
- Name, address, and contact person of the dealer who services your engine
- Date of purchase
- Your name, address and telephone number
- A detailed description of the problem

United States, Puerto Rico, and U.S. Virgin Islands:

American Honda Motor Co., Inc.

Power Equipment Division

Customer Relations Office

4900 Marconi Drive

Alpharetta, GA 30005-8847

Or telephone: (770) 497-6400, 8:30 am - 7:00 pm EST

Canada:

Honda Canada, Inc.

715 Milner Avenue

Toronto, ON

M1B 2K8

Telephone: (888) 9HONDA9 Toll free
(888) 946-6329

English: (416) 299-3400

French: (416) 287-4776

Facsimile: (877) 939-0909

(416) 287-4776

Local Toronto dialing area

Local Toronto dialing area

Toll free

Local Toronto dialing area

Australia:

Honda Australia Motorcycle and Power Equipment Pty. Ltd.

1954 - 1956 Hume Highway Campbellfield Victoria 3061

Telephone: (03) 9270 1111

Facsimile: (03) 9270 1133

For European Area:

Honda Europe NV.

European Engine Center

<http://www.honda-engines-eu.com>

All Other Areas:

Please contact the Honda distributor in your area for assistance.

HONDA
The Power of Dreams

11. Overensstemmelseserklæring.

Hedensted Gruppen A/S

Vejlevej 15,
8722 Hedensted
Tlf. (+45) 75 89 12 44
Fax (+45) 75 89 11 80
www.hedensted-gruppen.dk

- erklærer hermed at:

HG S.S. Hydra Combi
Typenummer 280134

- er i overensstemmelse med:

Maskindirektivet 2006/42/EF

- under anvendelse af harmoniserede standarder.

DS/EN 12100-1:2005

DS/EN 60439-3

DS/EN 13857:2008

14. december 2009

Jens Jørgen Madsen
Direktør

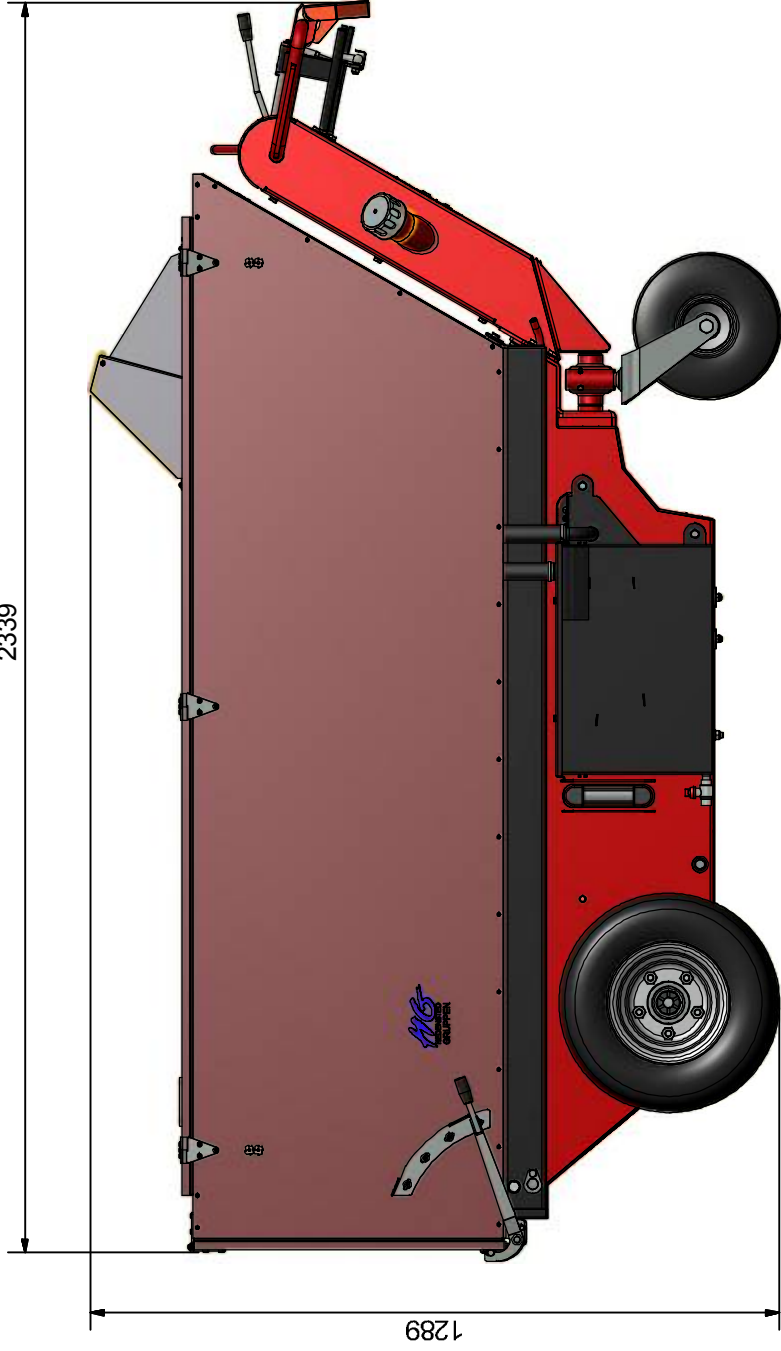
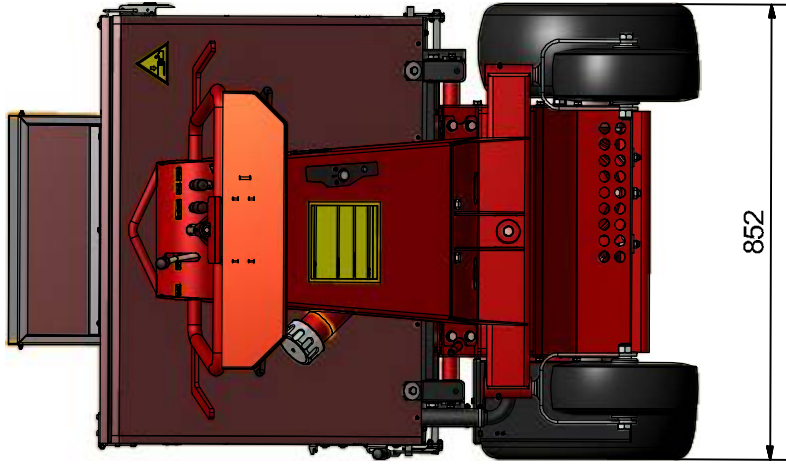

REV	DESCRIPTION	DATE	APPROVED
A	Made	10-01-2011	KC
B	Part list changed	18-06-2013	MRH
C	Updated - bumper added	24-04-2014	MRH
D	Hinge to lid changed	16-11-2014	KL

Alle kanter reifes
Breake all edges

	Scale:	Make angle/tolerance fit / Not specified tolerance according to:	Konst./Designed:
		DS/ISO 2768-m	
Hedensted Gruppen	Overall, basket/feet/Surface properties:		Approved/Drawn:
Part No.: 280133	Material/Updating according to:	Material:	Date:
Description: Hydra Combi with Killingbox			10-01-2011
Description:			
Sheet part drawn by: KC	Sheet part last saved: 10-01-2011	Sheet size: A3	Sheet: 1 / 3

The document is safety-critical information and account for errors or deviations in field use.
HEDENSTED GRUPPEN A/S

Parts List

ITEM	QTY	PART NUMBER	DESCRIPTION
3	1	422558	Frame part 10
4	1	441805	Exhaust for Hydra
5	3	11408016	Hexagon bolt M8x16 FZB
6	3	82108000	Washer M8 FZB

Wrap the parts in plastic put inside box

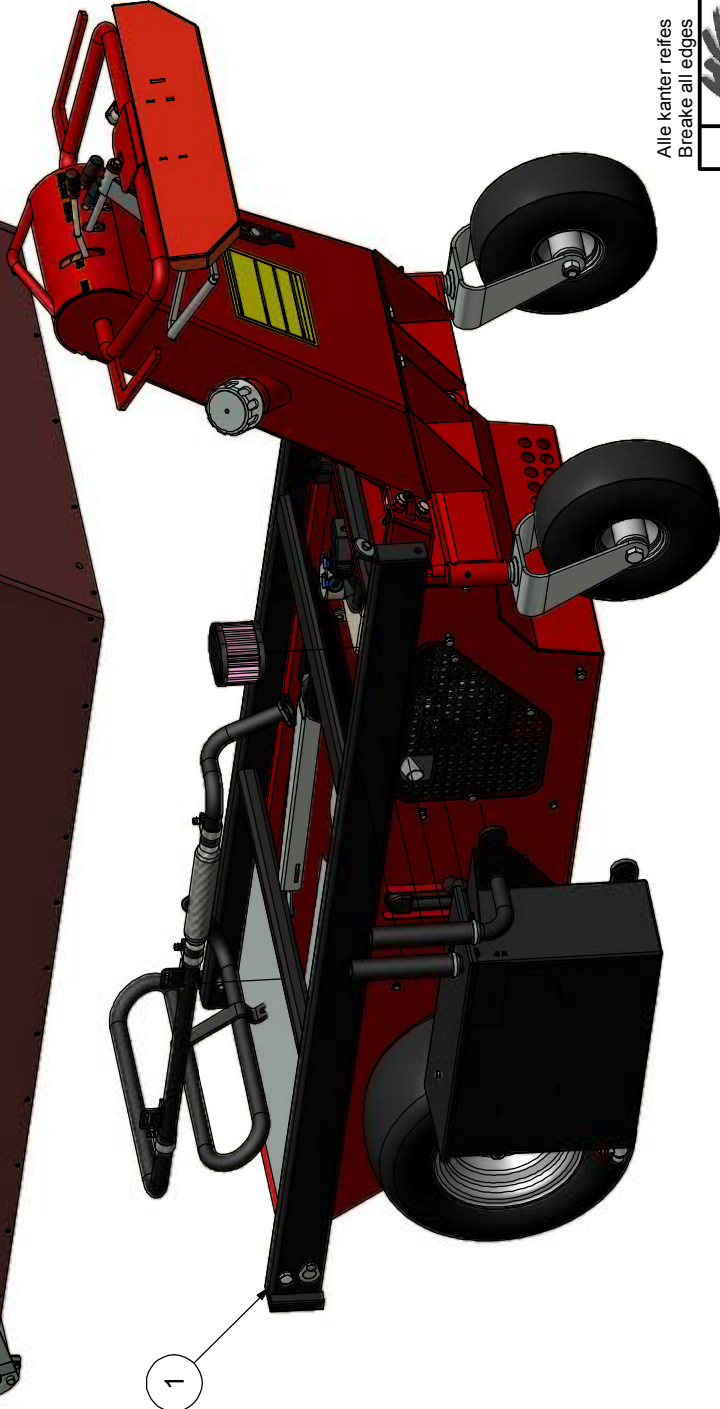
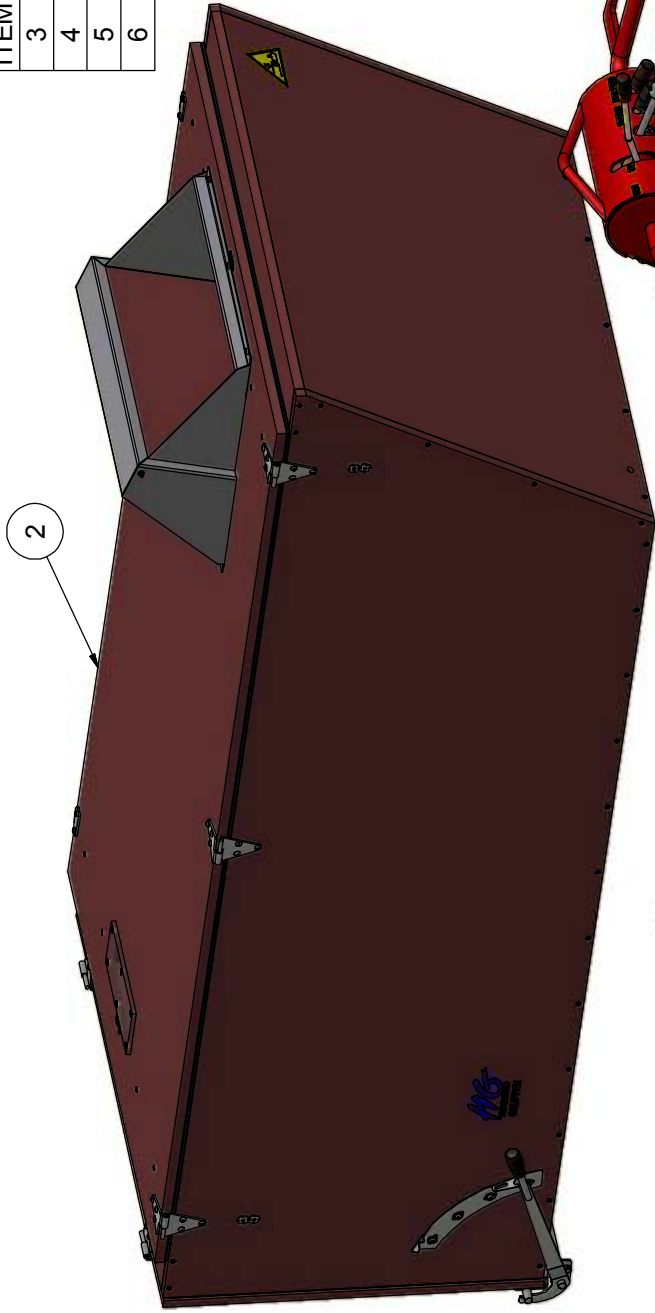
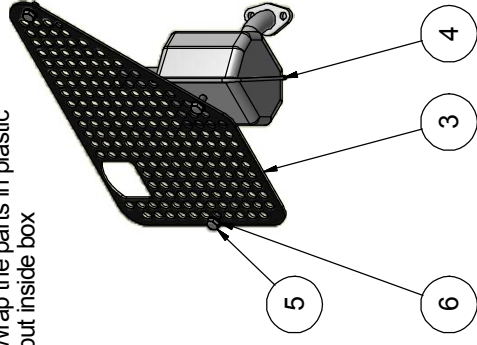

Alle kanter reifes
Breake all edges

H6
Hedensted Gruppen
280133

Scale: Note angle/tolerance fill / Not specified tolerance according to: DS/ISO 2768-m
Overfill, basket/height/Surface, properties:
Date: 10-01-2011

Material: Material:
Part No.: 280133
Description: Hydra Combi with Killingbox

Sheet: part of sheet number: KC
Sheet size: A3
Sheet: 2 / 3

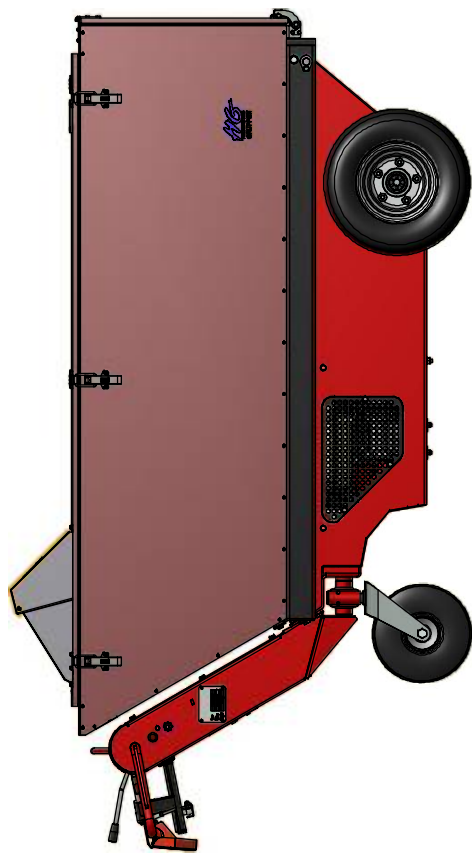
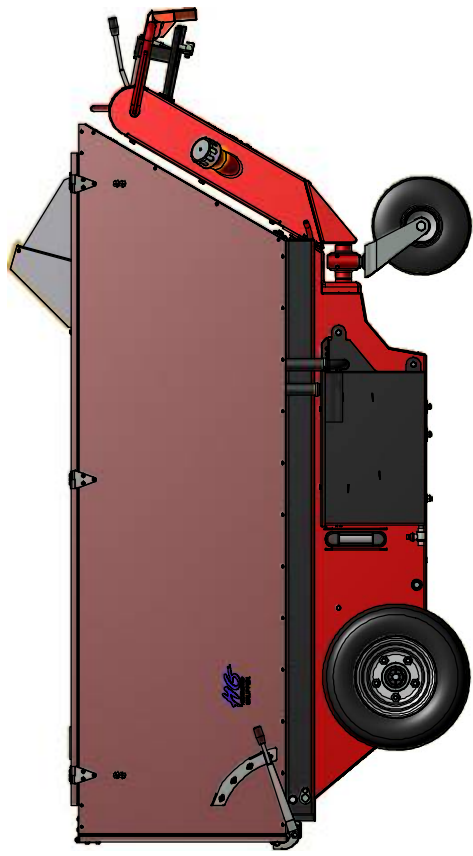
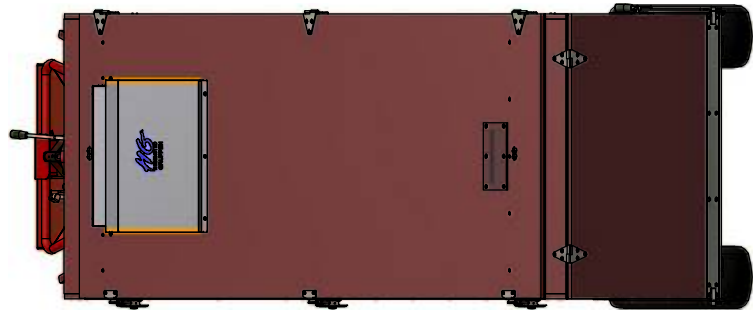

Parts List	
ITEM	QTY PART NUMBER DESCRIPTION
1	1 280134 HG SS Hydra Combi electrical start
2	1 280150 Killing box 120 males

The document is safety-critical information and should not be used or released in any form without the written consent of HEDENSTED GRUPPEN A/S



Parts List		
ITEM	QTY	DESCRIPTION
1	1	HG SS Hydra Combi electrical start
2	1	Killing box 120 males

Alle kanter reifes
Breake all edges

 Hedensted Gruppen	Scale:	Make angle/tolerance fill / Not specified tolerance according to:	Konst./Designed:
		DS/ISO 2768-m	DS/ISO 2768-m
Part No.:	280133	Overfill, basket/height/Surface, properties:	Legnet/Drafted:
Description:	Hydra Combi with Killingbox	Material:	Date:
The document is safety-critical and therefore only account for errors or deviations any third person.		HEDENSTED GRUPPEN A/S Material:	10-01-2011
Sheet print created by: KC		Sheet print last saved: 10-01-2011	Sheet size: A3 Sheet: 3 / 3

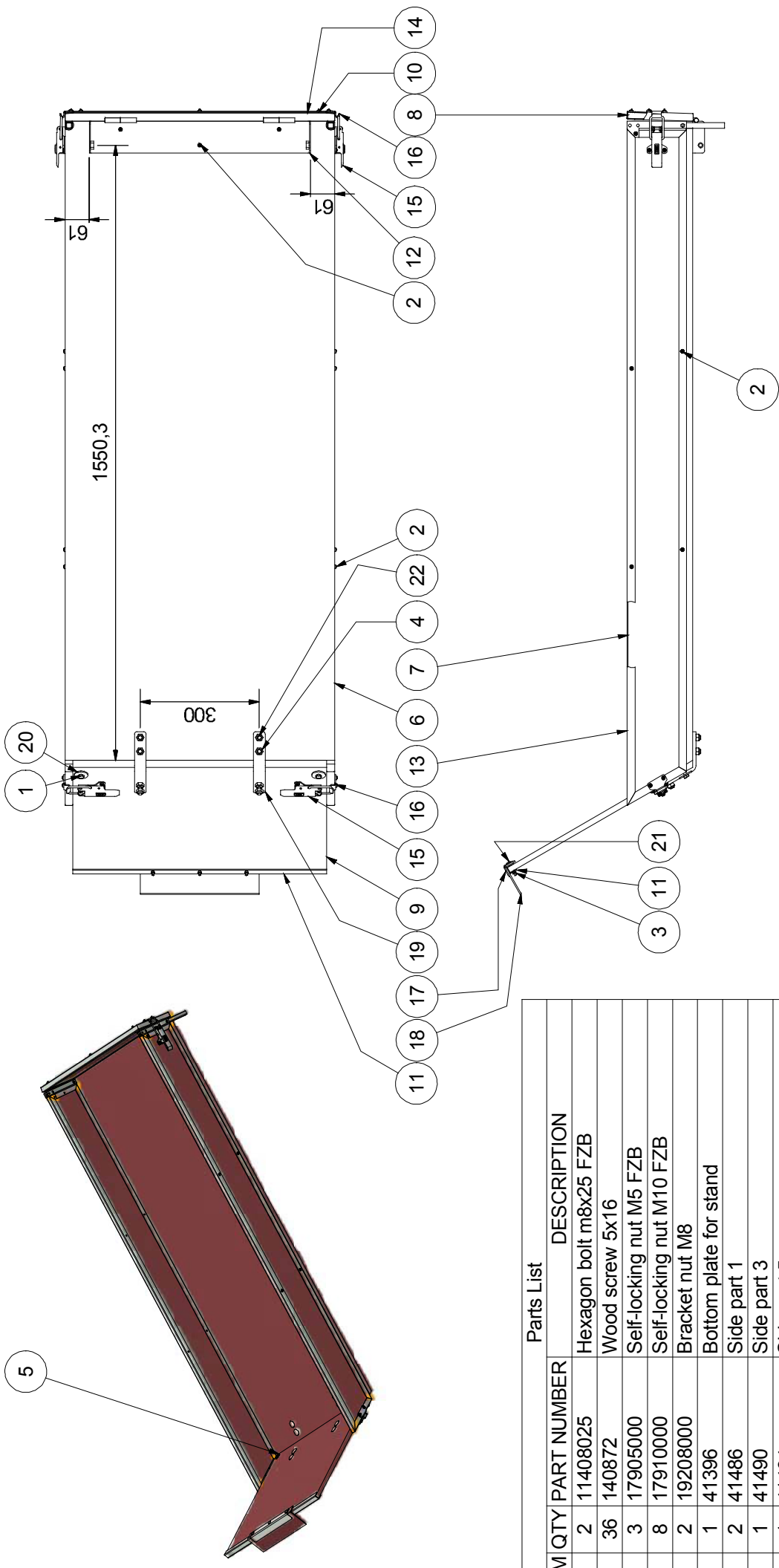

Parts List	
ITEM QTY	PART NUMBER DESCRIPTION
1	2 11408025 Hexagon bolt m8x25 FZB
2	36 140872 Wood screw 5x16
3	3 17905000 Self-locking nut M5 FZB
4	8 17910000 Self-locking nut M10 FZB
5	2 19208000 Bracket nut M8
6	1 41396 Bottom plate for stand
7	2 41486 Side part 1
8	1 41490 Side part 3
9	1 41494 Side part 5
10	1 41582 U-profil part 14
11	1 41583 U-profil part 15
12	1 422500 Brace for stand
13	2 422540 Frame 1
14	1 422544 Frame 3
15	4 422604 Latch with lock
16	4 422606 Brace for latch
17	1 422618 Brace for dirt deflector
18	1 422620 Rubber for dirt deflector
19	2 422622 Brace for stand
20	2 4809335 Washer type SRKB ø9x35x3
21	3 64405035 Cup head square neck bolt M5x35 FZB
22	8 64410035 Cup head square neck bolt M10x35 FZB

Alle kanter reifies

Scale: DS/ISO 2768-m
 Overfit: beskæftiget/Surface properties:
 Underfit: løsning according to: Material: 23-04-2009

Part No.: 280151
 Material: 23-04-2009

Revision: Flat bed for Hydra Combi
 Description: Flat Stand
 Sheet number: 1 / 1

REVISION HISTORY	
REV	DESCRIPTION DATE APPROVED
A	Made 02-07-2009 KC
B	Renamed 17-01-2011 KC

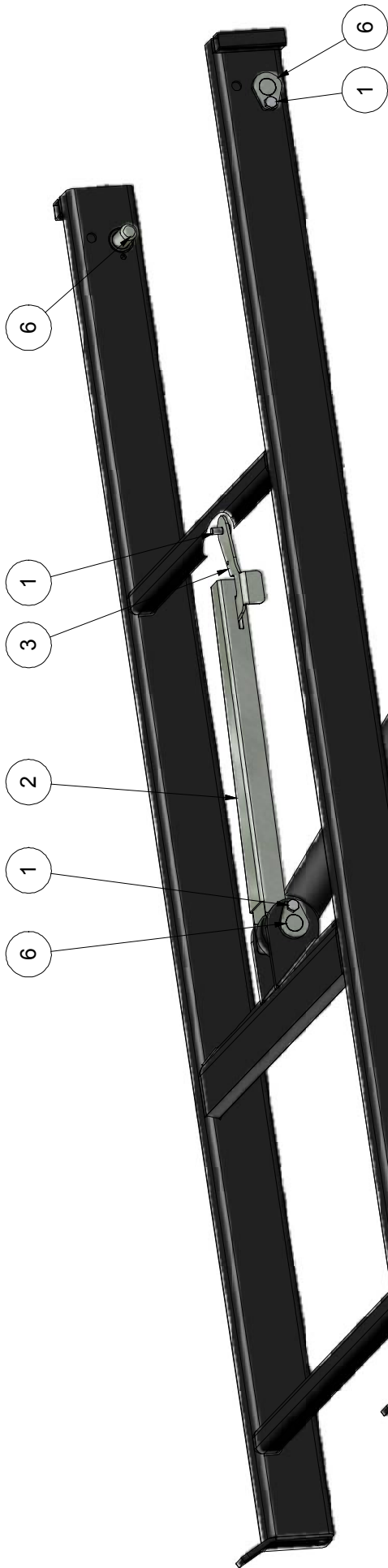

A < 1 : 1 >

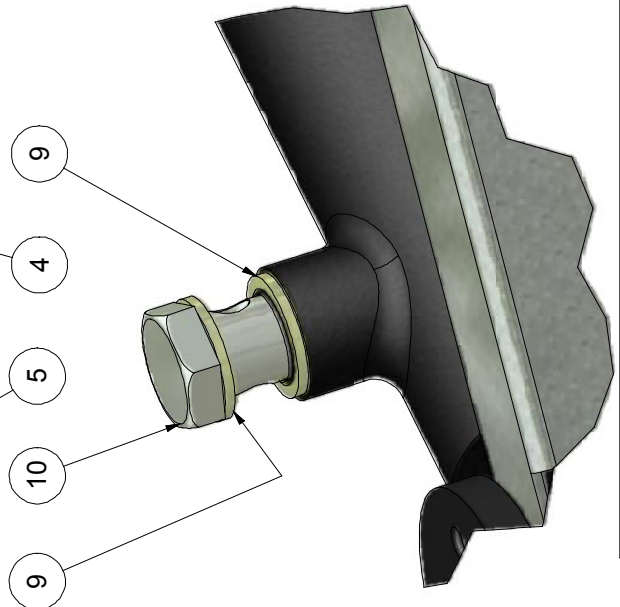
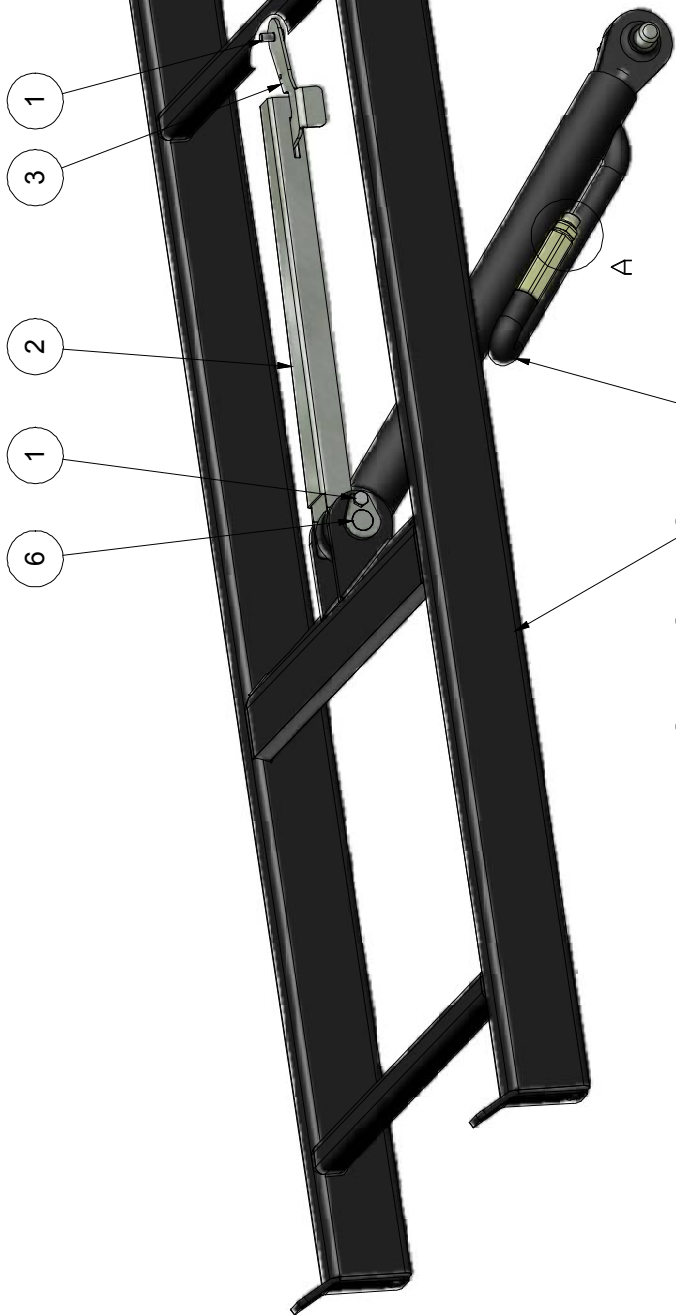
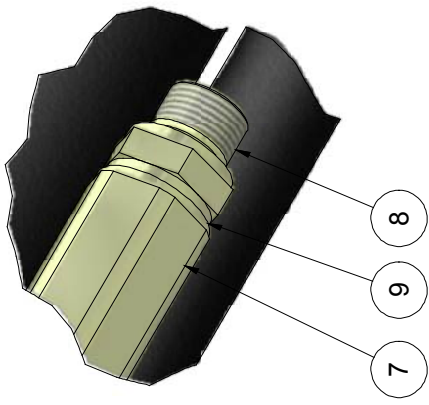

Parts List	
ITEM	QTY PART NUMBER DESCRIPTION
1	5 11408016 Hexagon bolt m8x16 FZB
2	1 41468 Stand part 11
3	1 41470 Stand part 12
4	1 422502 Cylinder for Hydra Combi
5	1 422532 Stand
6	4 423409 Jurnal for cylinder
7	1 423462 Hose leak valve
8	1 477100 Male stud 3/8"
9	3 477163 Bopnded seal washer 3/8"
10	1 477222 Banjo bolt 3/8" bsp

Alle kanter reifes
Breake all edges

Scale:	Alle angivet tolerancer til / Not specified tolerances according to:	Konst./Designed:
	DS/ISO 2768-m	
	Overfl. beskaffenhed/Surface properties:	tegnet/Drawn:
Part No.:	Material:	Date:
422674		06-01-2011
Description: Stand assembly		
Revision: 1 / 1		
Sheet:	1 / 1	

REV	DESCRIPTION	DATE	APPROVED
A	Made	06-01-2011	KC

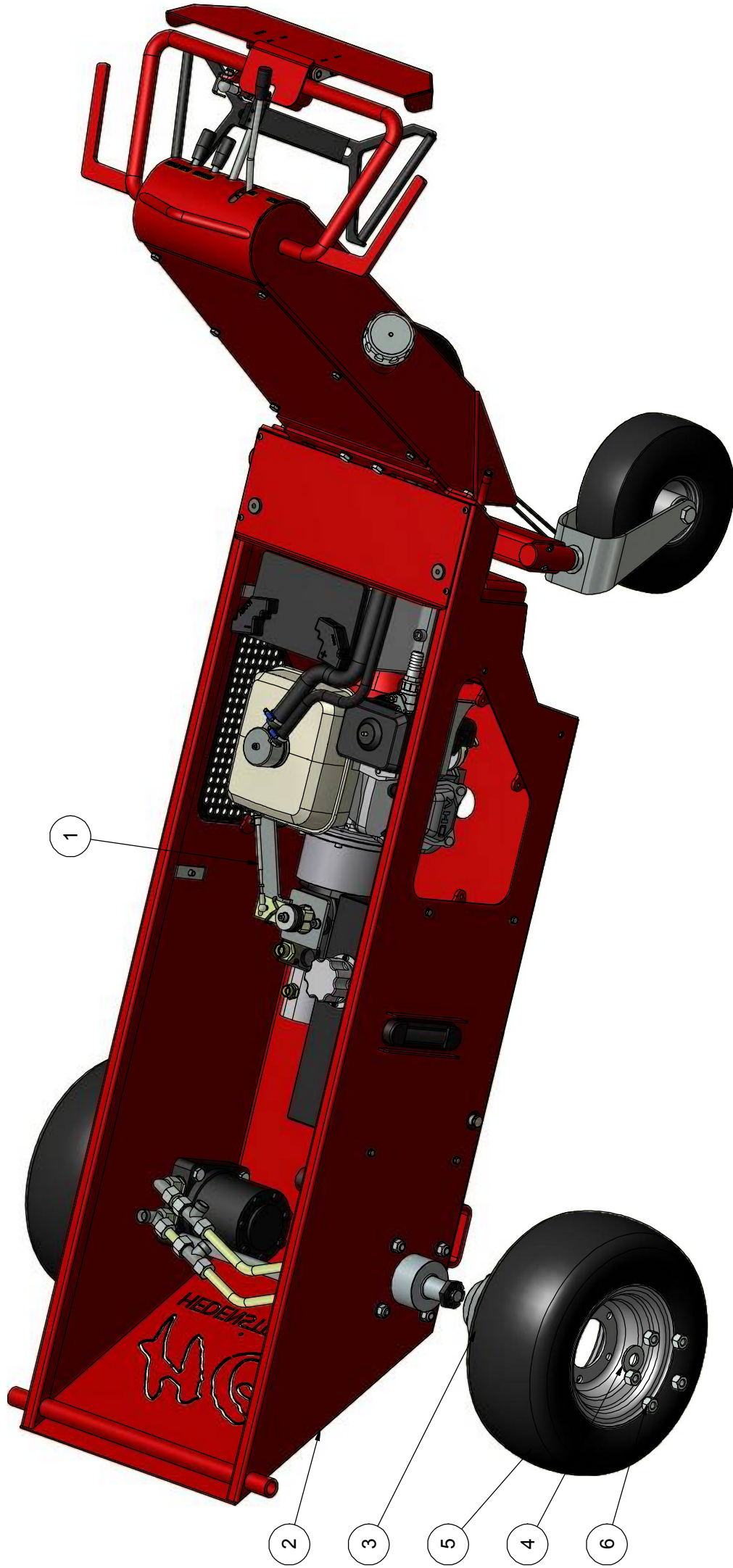

Alle kanter reifes
Breake all edges

	State:	Alle angivet tolerancer til / Not specified tolerances according to:	Konst. / Designed:
		DS/ISO 2768-m	
	Overfl. baskel / Surface properties:		Approved:
	Material / Material:		Date:
	Part No.:	422686	07-01-2011
Description:		Third base assembly	
State generated by:		KC	Sheet size: A3
Date:		07-01-2011	Sheet: 1 / 1

Parts List		DESCRIPTION
1	422632	Steering cable for Hydra combi
2	422684	Second base assembly
3	423471	Wheel hub model 97
4	423545	Washer f/OMRW 45x20,5x4 FZB
5	474733	Wheel F LP190-8-8 HF400 silver
6	479910	Wheel nut M12x1,5 NV22 60° FZB

REVISION HISTORY		
REV	DESCRIPTION	DATE
A	Made	07-01-2011
B	Steering cabel added	11-06-2013
	APPROVED	MRH

Parts List

ITEM	QTY	PART NUMBER	DESCRIPTION
1	3	11408016	Hexagon bolt M8x16 FZB
2	2	11408025	Hexagon bolt M8x25 FZB
3	1	422560	Frame part 12
4	1	422668	Wheel motor assembly
5	1	422670	Hydraulic tank assembly
6	1	422682	First base assembly
7	2	423601	Hose clamp
8	1	477404	Hydraulic hose 1. 3/4" x 825mm
9	1	477406	Hydraulic hose 2. 1/2" x 500mm
10	1	477408	Hydraulic hose 3. 1/2" x 1780mm
11	1	477410	Hydraulic hose 4. 1/2" x 460mm
12	1	477412	Hydraulic hose 5. 1/2" x 1420mm
13	1	477414	Hydraulic hose 6. 3/8" x 2200mm
14	1	477416	Hydraulic hose 7. 3/8" x 2690mm
15	1	477418	Hydraulikslange 8. 3/8" x 1625mm
16	1	477420	Hydraulikslange 9. 3/8" x 1820mm
17	1	477422	Hydraulikslange 10. 1" x 530mm
18	5	82108000	Washer M8 FZB

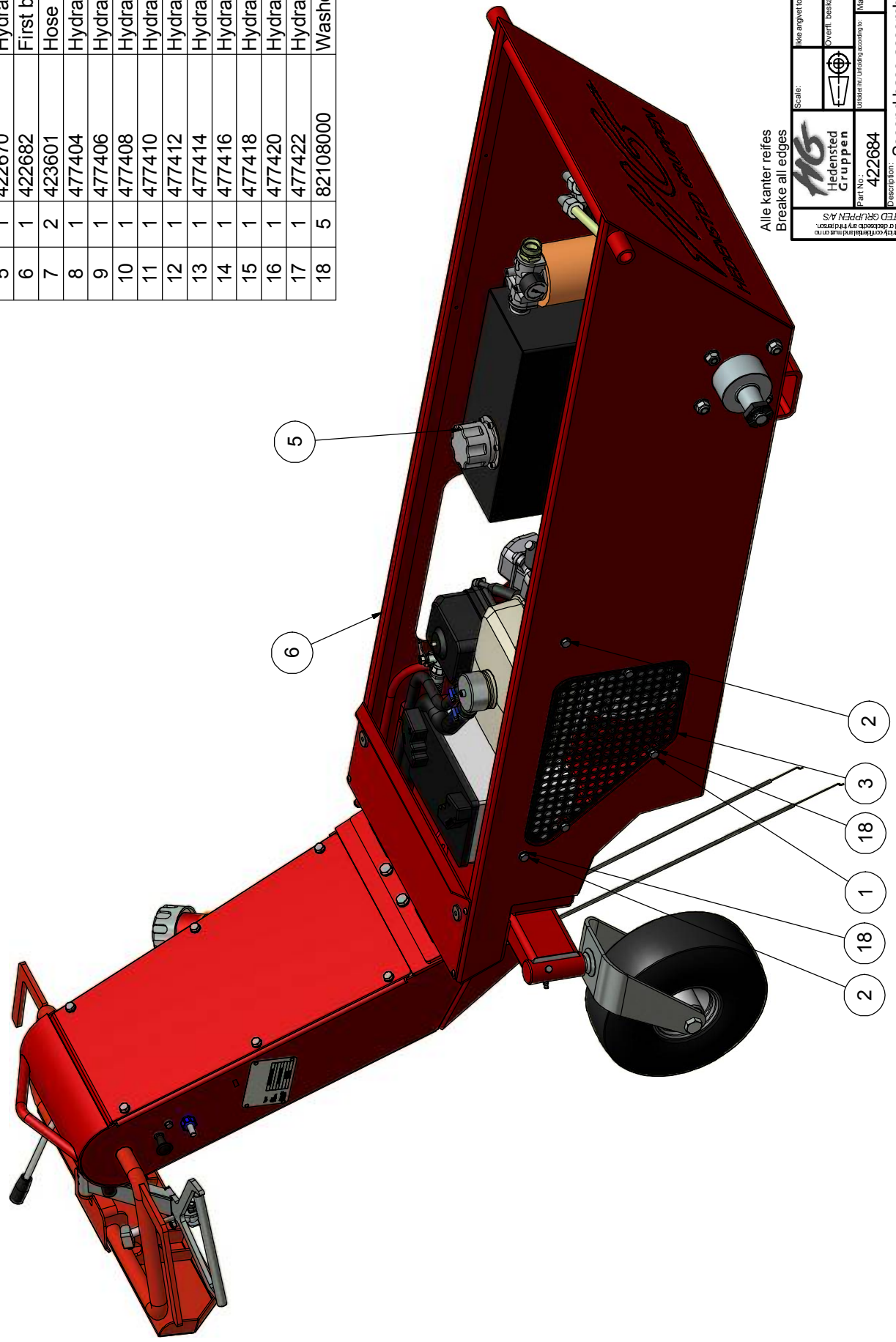

Alle kanter reifes
Breake all edges

	Scale:	Make angles tolerances fit / Not specified tolerances according to:	Const. / Designed:
		DS/ISO 2768-m	DS/ISO 2768-m
	Overfit. basket / head / Surface properties:		Approved / Drafted:
Part No.:	Material:	Date:	
422684		07-01-2011	
Description:		Second base assembly	
Description:			
Sheet part and assembly:	KC	Sheet part and assembly:	07-01-2011
Sheet size:	A3	Sheet:	2 / 2

The document is safety-critical information and should not be distributed any further.
HEDENSTED GRUPPEN AS

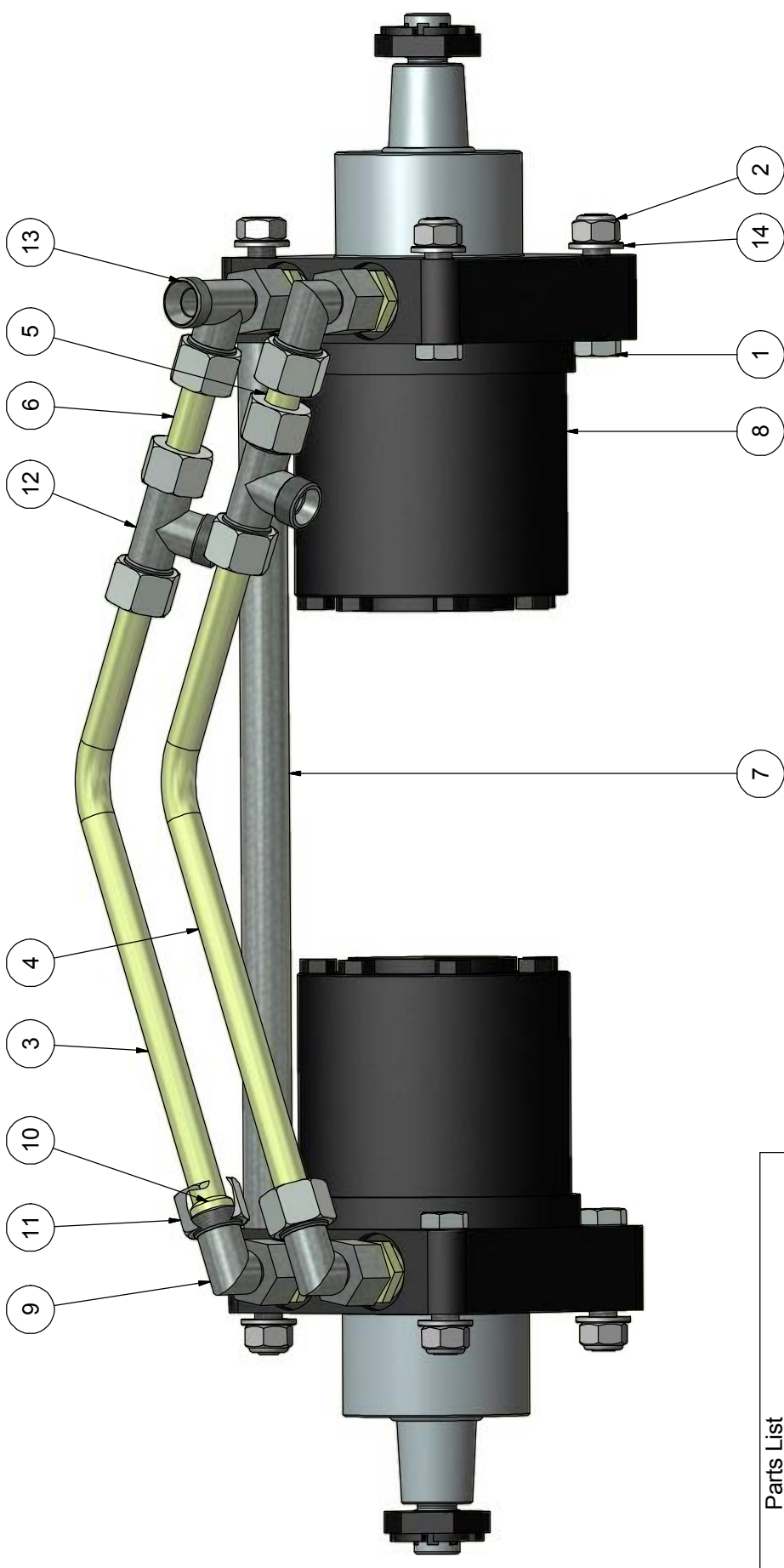

Parts List

ITEM	QTY	PART NUMBER	DESCRIPTION
1	6	11412055	Hexagon bolt 12 x 55 FZB
2	7	17912000	Self-locking nut M12 FZB
3	1	422624	Hydraulic pipe 1 for motor
4	1	422626	Hydraulic pipe 2 for motor
5	1	422628	Hydraulic pipe 3 for motor
6	1	422630	Hydraulic pipe 4 for motor
7	1	423442	Pipe for wheel motor
8	2	423519	Hydraulic wheel motor
9	3	424048	Adjustible elbow 15L DM
10	8	424118	Cutting ring 15L
11	8	424122	Union 15L M22x1,5
12	2	424162	Equal tee 15-L M22x1,5
13	1	477072	Adjustible tee SL15 L
14	8	82112000	Washer M12 FZB

REV	DESCRIPTION	DATE	APPROVED
A	Made	2011-01-04	KC
B	Fitting removed	11-06-2013	MIRH

Alle kanter reifes
Breake all edges

 Scale: None angivet tolerance / Not specified tolerance according to: DS/ISO 2768-m
 Overfl. basket/hand/Surface properties:
 Part No.: 422668 Material:
 Date: 2011-01-04
 Description: Wheel motor assembly
 Sheet: 1 / 2

The document is safety-critical information and is not to be used or released in any form without the prior written consent of Heddensted Gruppen AS.

A < 1 : 2 >

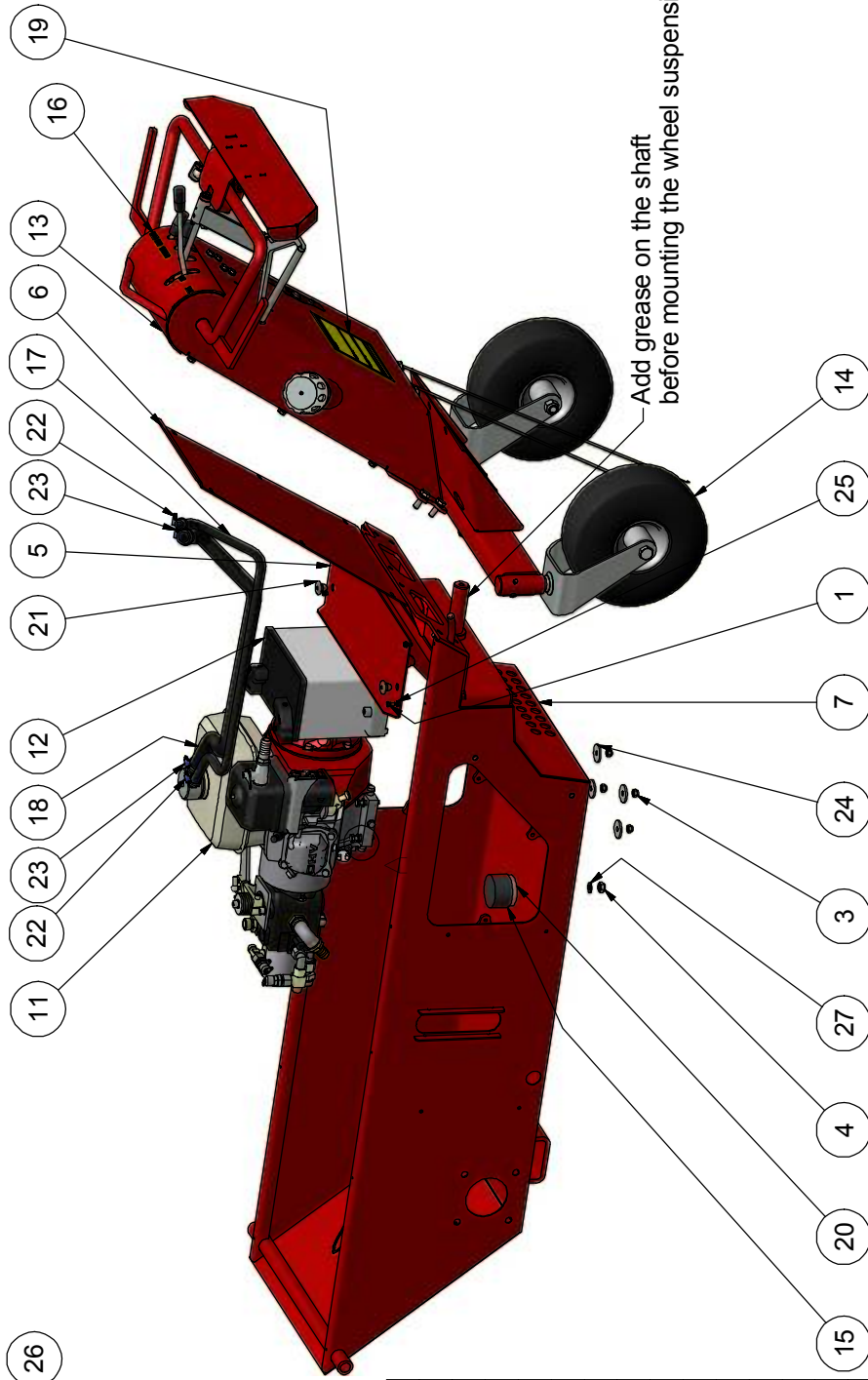
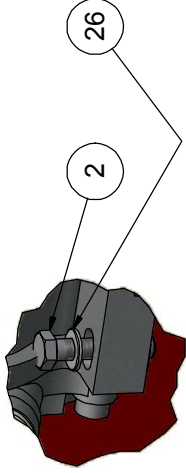

Add grease on the shaft
before mounting the wheel suspension

Parts List

ITEM	QTY	PART NUMBER	DESCRIPTION
1	4	11405012	Hexagon bolt M5x12 FZB
2	4	11408040	Hexagon bolt M8x40 FZB
3	4	17908000	Self-locking nut M8 FZB
4	1	17910000	Self-locking nut M10 FZB
5	1	422556	Frame part 6
6	1	422562	Frame part 17
7	1	422564	Frame assembly 1
8	1	422652	Red wire 16° Length 80 cm
9	1	422654	Black wire length 98 cm
10	1	422656	Wiring for engine
11	1	422660	Engine assembly 2
12	1	422676	Battery assembly
13	1	422678	Operator assembly
14	1	422680	Suspension assembly
15	1	423421	Vibration damper Ø65
16	1	423438	Logo for tilt and throttle
17	0,85 m	423451	Fuel hose L =850mm
18	0,85 m	423452	Fuel hose L =850mm
19	1	423477	Warning Logo DK
20	1	423542	Spacer for vibration damper
21	2	423606	Rubber plug for plate
22	2	474007	Hose clamp 14-22
23	2	474008	Hose clamp 22-30
24	4	4809335	Washer type SRKB ø9x35x3
25	4	82105900	Washer M5 FZB
26	4	82108000	Washer M8 FZB
27	1	82110000	Washer M10 FZB

REVISION HISTORY

REV	DESCRIPTION	DATE	APPROVED
A	Made	07-01-2011	KC
B	Components added	11-06-2013	MIRH
C	Bolt in 422556 changed	16-11-2014	KL

Alle kanter reifes
Breake all edges

Scale: Note angle tolerance // Not specified tolerance according to: DS/ISO 2768-m
 Overfit. basket (end)/Surface properties:
 Part No.: 422682
 Material:
 Date: 07-01-2011
 Description: First base assembly
 Sheet: 1 / 2

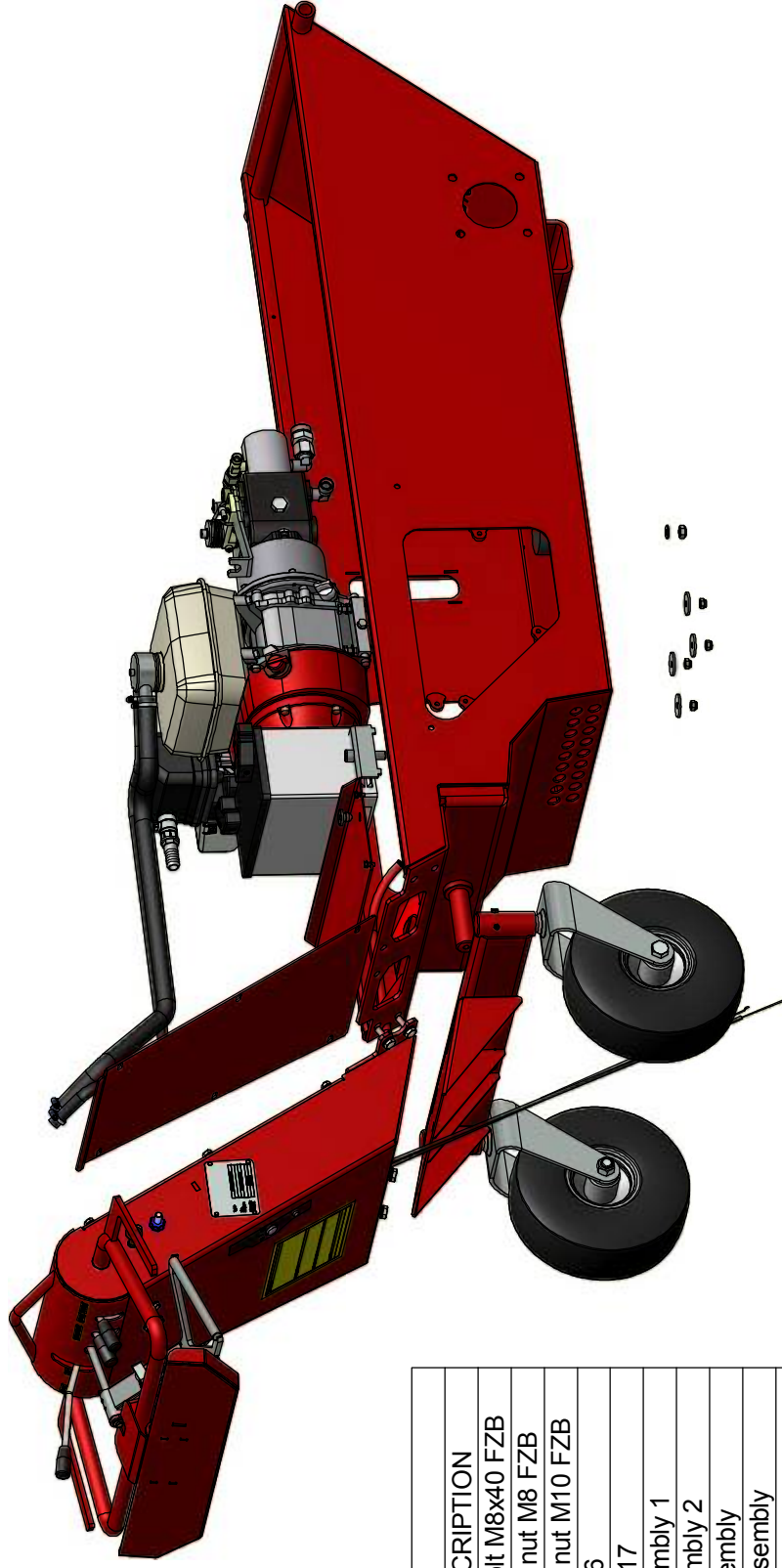

Parts List		
ITEM	QTY	PART NUMBER DESCRIPTION
2	4	11408040 Hexagon bolt M8x40 FZB
3	4	17908000 Self-locking nut M8 FZB
4	1	17910000 Self-locking nut M10 FZB
5	1	422556 Frame part 6
6	1	422562 Frame part 17
7	1	422564 Frame assembly 1
11	1	422660 Engine assembly 2
12	1	422676 Battery assembly
13	1	422678 Operator assembly
14	1	422680 Suspension assembly
15	1	423421 Vibration damper Ø65
16	1	423438 Logo for tilt and throttle
17	0,85 m	423451 Fuel hose L=850mm
18	0,85 m	423452_ Fuel hose L=850mm
19	1	423477 Warning Logo DK
20	1	423542 Spacer for vibration damper
21	2	423606 Rubber plug for plate
22	2	474007 Hose clamp 14-22
23	2	474008 Hose clamp 22-30
24	4	4809335 Washer type SRKB ø9x35x3
26	4	82108000 Washer M8 FZB
27	1	82110000 Washer M10 FZB
8	1	422652 Red wiere 16° Length 80 cm
9	1	422654 Black wire length 98 cm
10	1	422656 Wiring for engine
25	4	82105900 Washer M5 FZB
1	4	11405012 Hexagon bolt M5x12 FZB

Alle kanter reifes
Breake all edges

Scale: Make angles/ tolerances fit / Not specified tolerances according to: DS/ISO 2768-m
Overfit, basket/height/Surface, properties: Hedensted Gruppen
Date: 07-01-2011
Part No.: 422682
Material: Hedensted Gruppen AS
Description: First base assembly
Sheet: 2 / 2

The document is safety-critical information and should not be distributed outside the company.

Parts List

ITEM	QTY	PART NUMBER	DESCRIPTION
1	6	10206020	Bolt unbraco cyl 6x20 FZB
2	1	10506010	Stop screw 6x10 mm black
3	2	11410030	Hexagon bolt M10x30 FZB
4	4	20408025	Hexagon countersunk 8x25 FZB
5	1	207946	Key 5x5x25mm DIN-6885A
6	1	422658	Ingine assembly 1
7	1	422672	Hydraulic pump assembly
8	1	423470	Starter string 4,5 mm (1,58m)
9	1	423487	Housing for centrifugal clutch
10	0,6 l	476705	Engine oil Q8 T520 15W-40
11	2	82110000	Washer M10 FZB

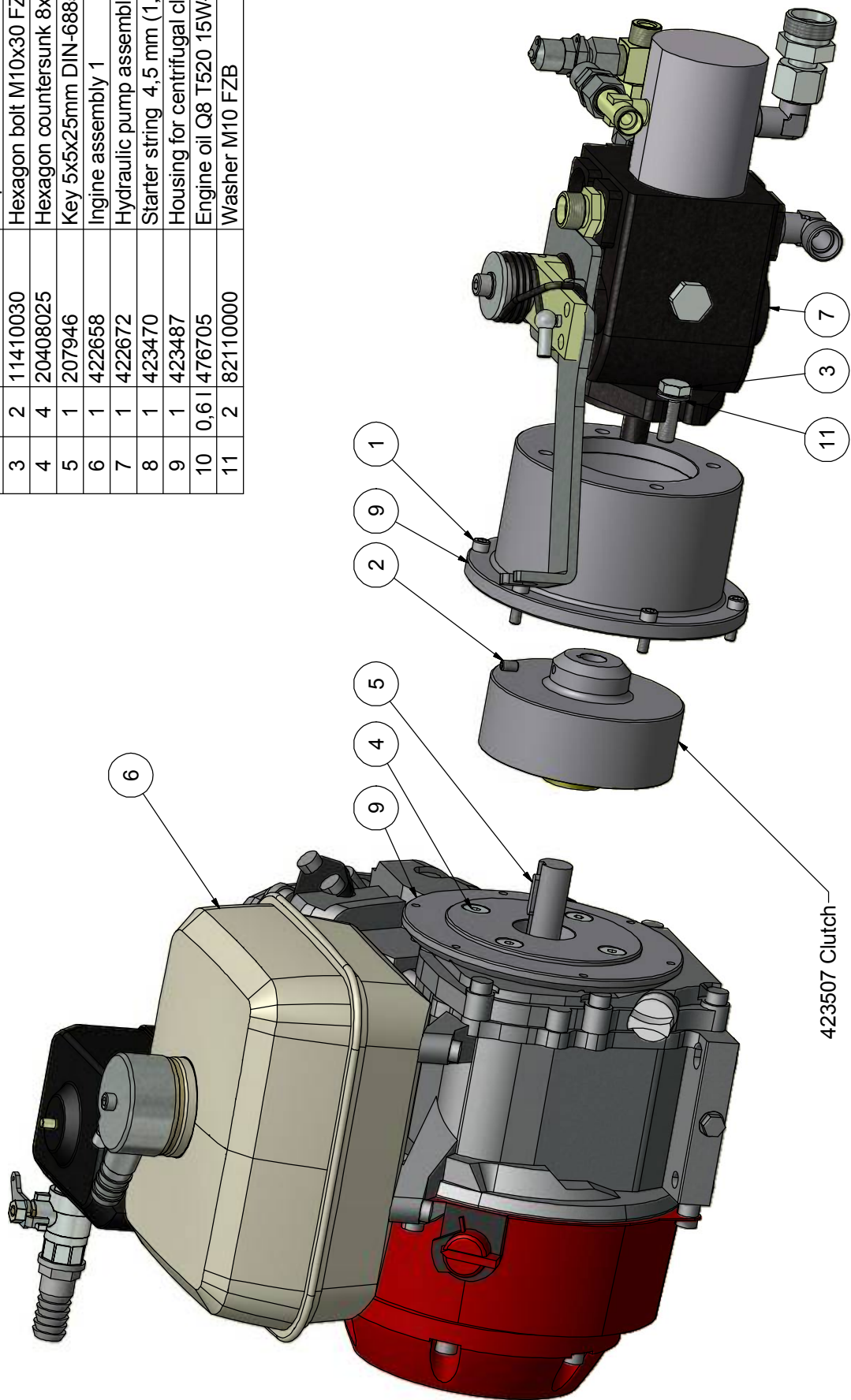

423507 Clutch

Alle kanter reifes
Breake all edges

Scale: Make angle/tolerance fit / Not specified tolerance according to: DS/ISO 2768-m
Overfit, basket/tenet/Surface properties: Konstr./Designed:
Part No.: 422660 Date: 23-01-2009
Description: ingine assembly 2
Material:
Sheet size: A3 Sheet: 1 / 1

REV	DESCRIPTION	DATE	APPROVED
A	Made	05-01-2011	
B	Oil added to drawing	11-06-2013	MIRH
C	Changed	13-12-2013	MAC

Parts List

ITEM	QTY	PART NUMBER	DESCRIPTION
1	2	10212050	Bolt.unbraco cyl 12x50 FZB
2	1	421419	Negative terminal
3	2	423467	Brace for battery
4	1	423496	Cover for positive terminal
5	1	423497	Cover for gorund terminal
6	1	423529	Positive terminal
7	1	476010	Battery

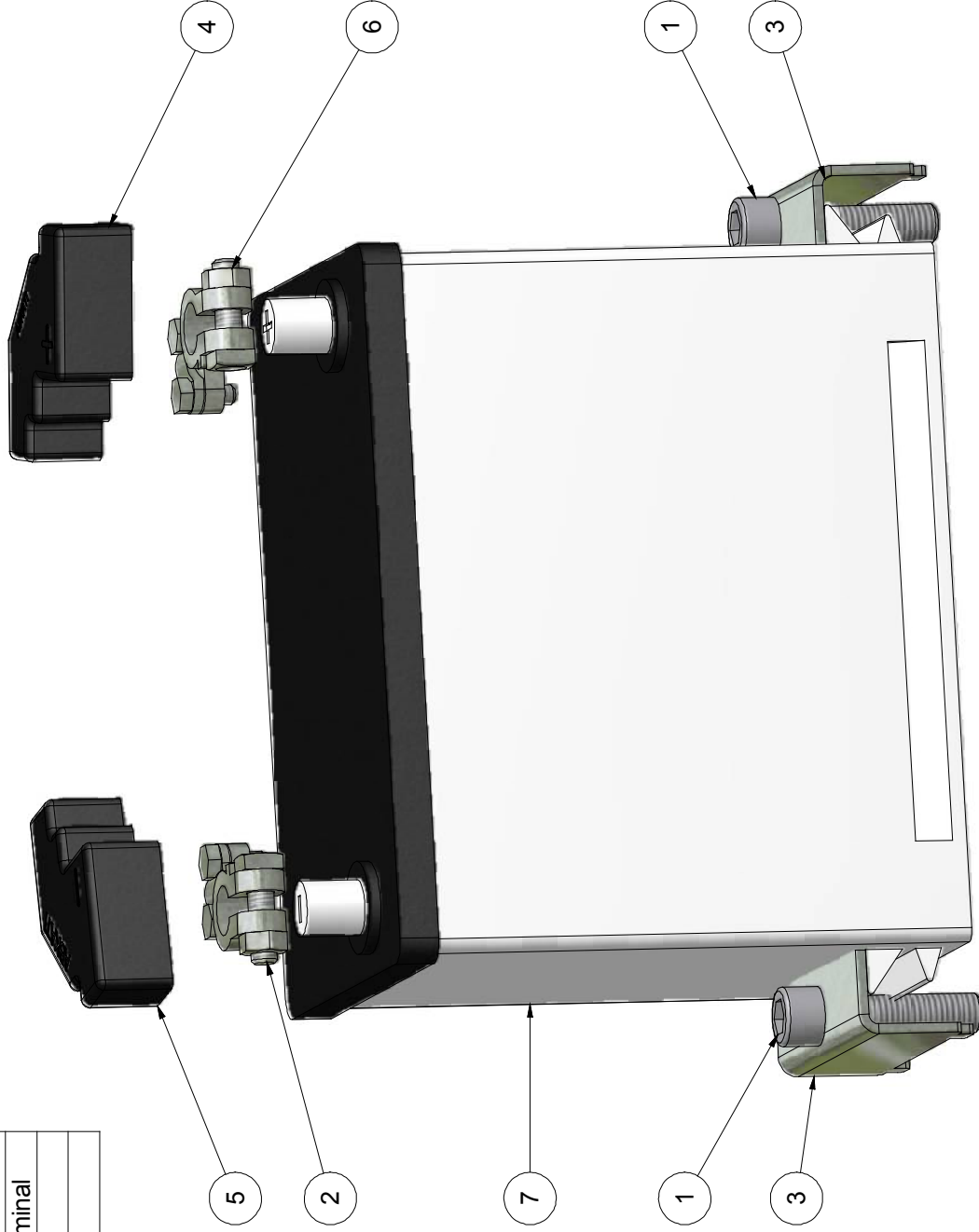

Alle kanter reifes
Breake all edges

	Scale:	Alle angivet toleranser till / Not specified tolerances according to:	Konst./Designed:
		DS/ISO 2768-m	DS/ISO 2768-m
Hedensted Gruppen		Överf. beskrifning/Surface properties:	Yegne/Drilled:
Part No.:	422676	Material:	KC
Description: Battery assembly		Date:	06-01-2011
REVISION HISTORY		Sheet 1 / 1	
REV	DESCRIPTION	DATE	APPROVED
A	Made	06-01-2011	KC

Parts List		DESCRIPTION
ITEM	QTY	PART NUMBER
1	1	10508050
2	2	11406016
3	1	11406020
4	6	11408016
5	1	11408035
6	8	11410030
7	2	1508000
8	2	17906000
9	3	17908000
10	1	30039
11	2	415042
12	1	422566
13	1	422640
14	1	422642
15	1	422663
16	1	422664
17	1	422666
18	3	423423
19	3	423424
20	1	423432
21	1	423443
22	1	423464
23	1	423570
24	1	423572
25	1	423590
26	1	441720
27	1	445091
28	1	470565
29	1	477117
30	1	477146
31	4	7003208
32	4	82106000
33	6	82108000
34	8	82110000
35	1	82606000
36	2	89505022
37	1	M100499
38	1	M100501
39	1	M100503
40	2	M100507
41	1	M100772

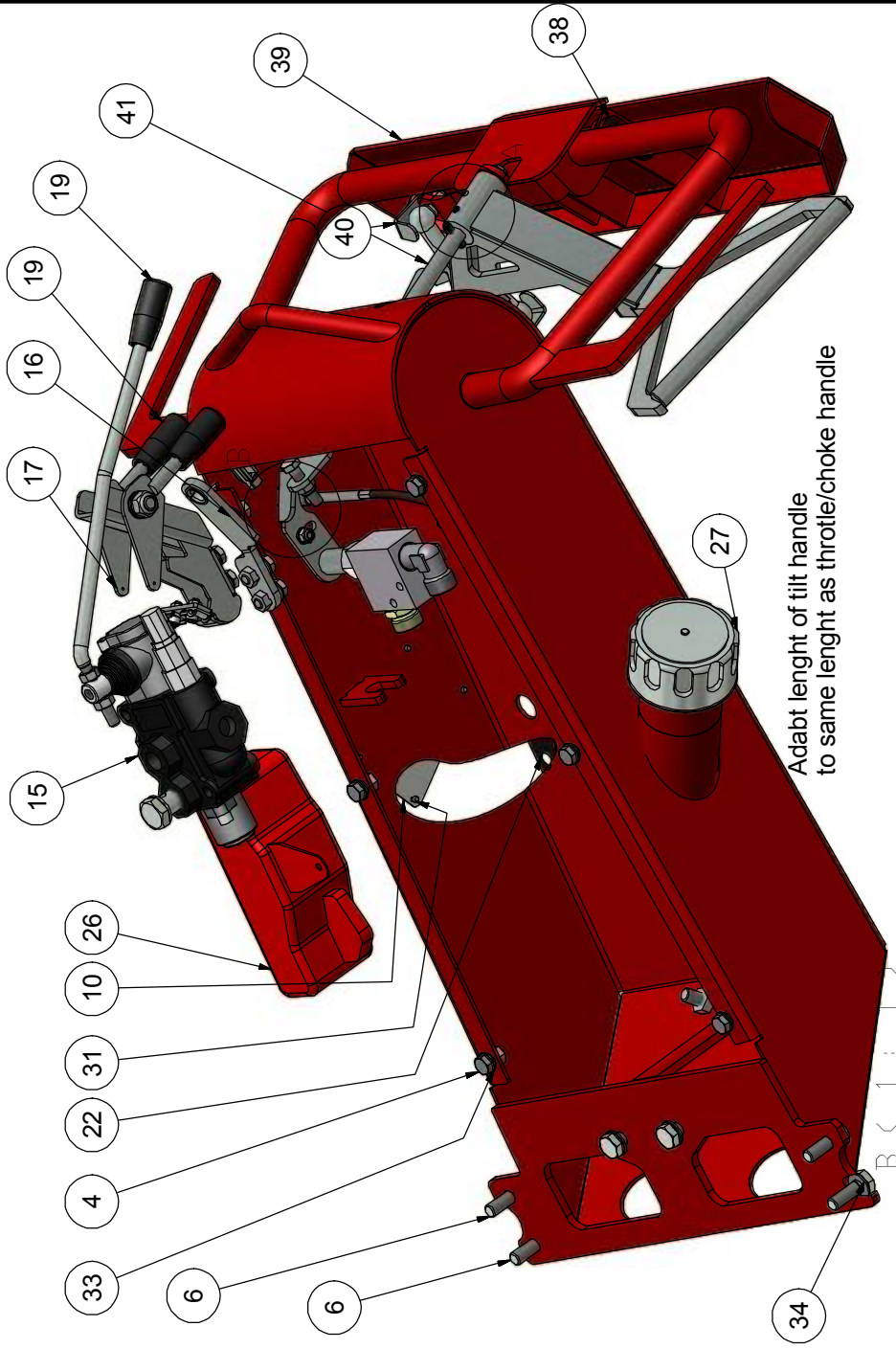

Adapt length of tilt handle
to same length as throttle/choke handle

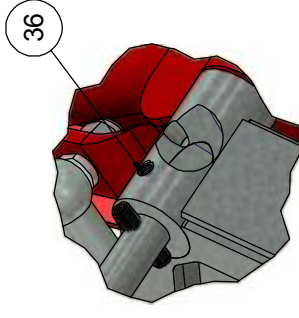
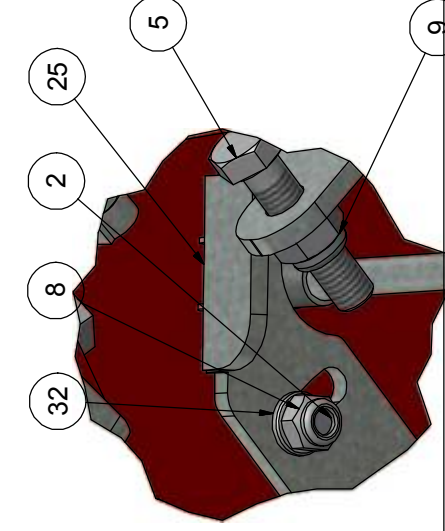

A < 1 : 1,5 >

Alle kanter reifes
Breake all edges

	Scale:	Make angle/tolerance // Not specified tolerance according to:	DS/ISO 2768-m
		Overfit. basket/fit/hole/surface properties:	
Part No.:	422678	Material:	
Date:	06-01-2011		
Description:		Operator assembly	
<small> The document is safety-critical information and is not to be distributed outside the company without prior approval. </small>			
<small> Konstr. / Designed by: </small>		<small> Date: </small>	
<small> Tegnet / Drawn by: </small>		<small> Sheet size: </small>	
<small> Checked by: </small>		<small> Sheet: </small>	
<small> Approved by: </small>		<small> 1 / 2 </small>	

REV	DESCRIPTION	DATE	APPROVED
A	Made	06-01-2011	
B	Cabels added	11-06-2013	MIRH

D < 1 : 1,5 >

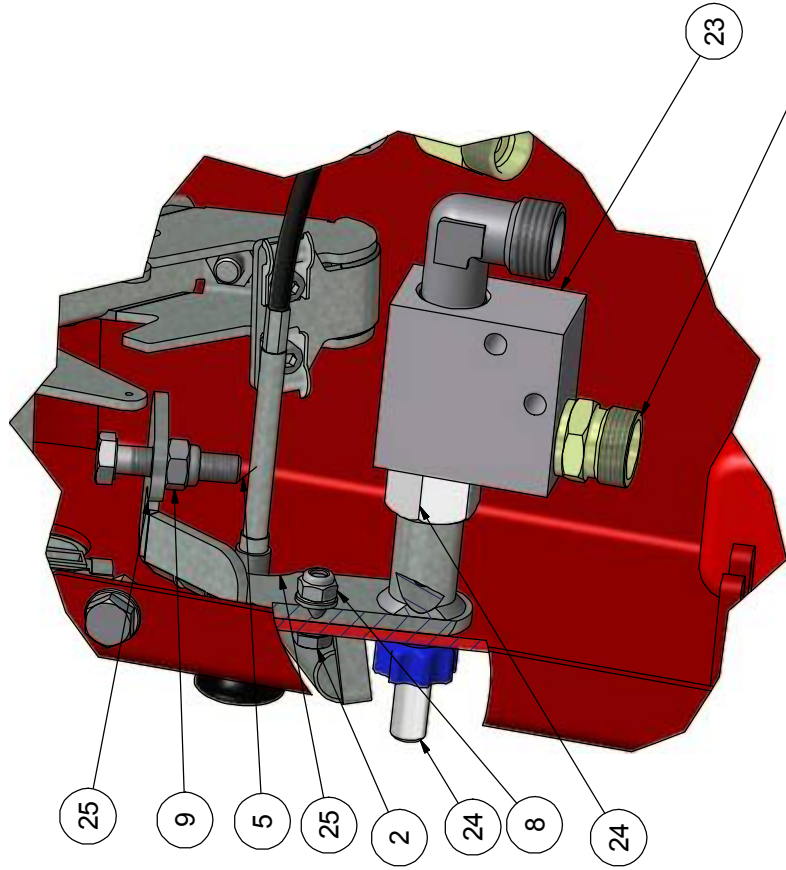

H < 1 : 1,5 >

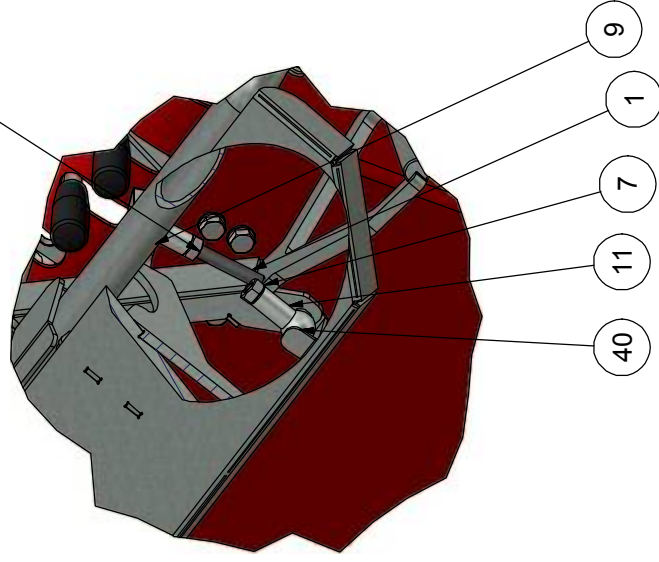
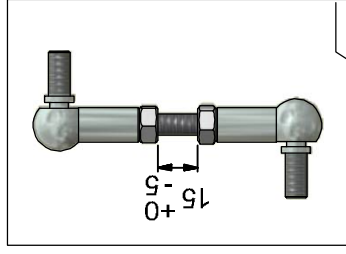
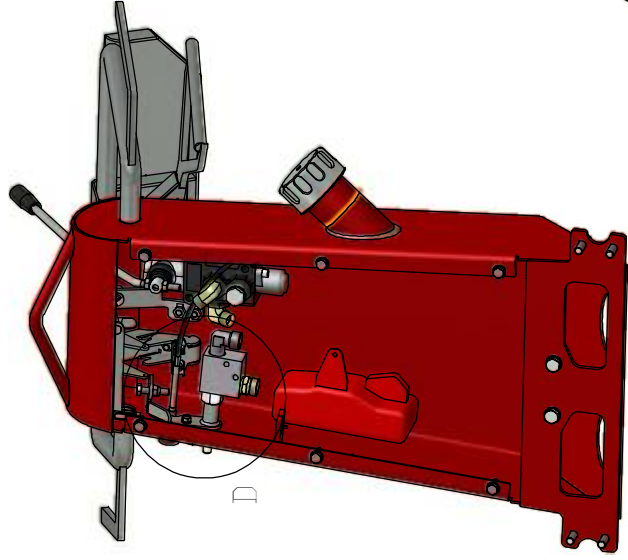
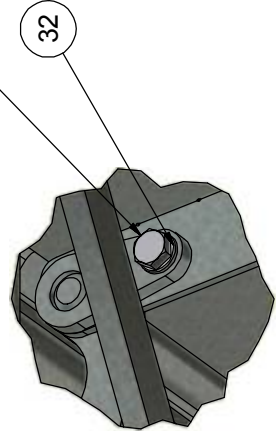

Alle kanter reifes
Breake all edges

	Scale:	Make angle/tolerance fit/Not specified tolerance according to:	Konst./Designed:
		DS/ISO 2768-m	
		Overfit. basket/fit/hole/surface properties:	Approved/Drilled:
Part No.:	Material:	Date:	
422678		06-01-2011	
Description:		Operator assembly	
HEDENSTED GRUPPEN AS			
The document is safety-critical information and account on card or otherwise any information.			
Sheet part of last sheet by:	06-01-2011	Sheet size:	A3
		Sheet:	2 / 2

Parts List

ITEM	QTY	PART NUMBER	DESCRIPTION
1	2	11406012	Hexagon bolt m6x12 FZB
2	1	11410030	Hexagon bolt 10x30 FZB
3	2	11416150	Hexagon bolt m16x150 FZB
4	2	17916000	Self-locking nut M16 FZB
5	2	422413	Slide Bearing PAF-30260 (34x30x26)
6	1	422512	Suspension movable part
7	1	422616	Reinforcement for control
8	2	423068	Grease fitting M6 straight
9	2	423465	Fork for wheel DGT 12"
10	2	423466	Fork wheel SS Hydra
11	1	43254	End plate Ø45
12	1	82110000	Washer M10 FZB

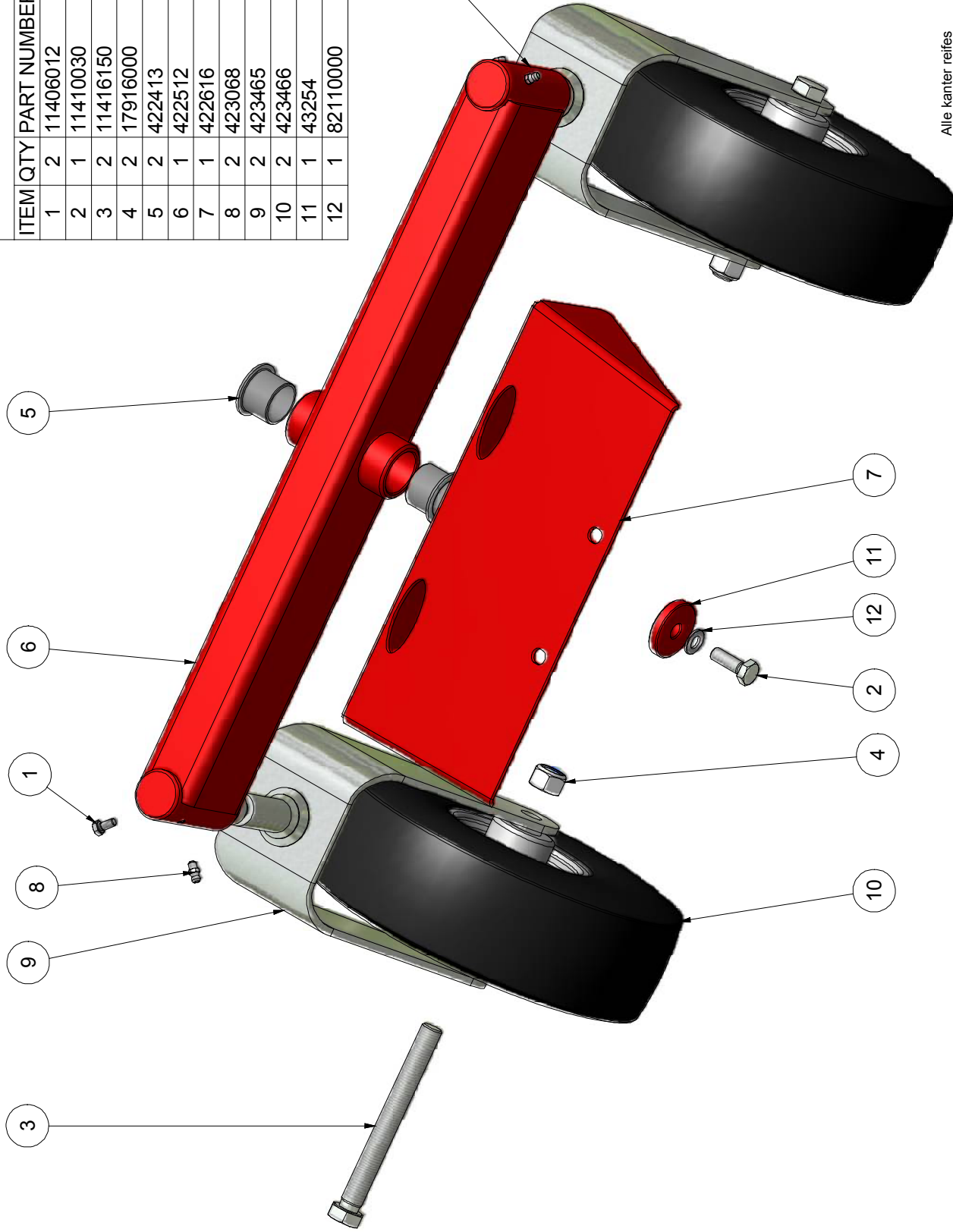

Add grease in both grease fittings

Alle kanter reifes
Breake all edges

 Hedensted Gruppen	Scale:	Ikke angivet tolerance (N) / Not specified tolerance according to: DS/ISO 2768-m	Konst./Designed:
	 Overfl. beskaffenhed/Surface properties:		Region/Region:
Part No.:	422680	Material:	Date:
Gennemsnit. længde/according to:			06-01-2011
Description:		Suspension assembly	
Revision:			
Revision History:			
REV	DESCRIPTION	DATE	APPROVED
A	Made	06-01-2011	KC
Skrevet/last saved by: KC		Skrevet/last saved: 06-01-2011	Sheet: A3
		Sheet 1 / 1	

Parts List

ITEM	QTY	PART NUMBER	DESCRIPTION
1	2	10205010	Bolt.unbraco cyl.5x10 FZB
2	1	10206050	Bolt.unbrako cyl 6x50 FZB
3	1	203930	Edge protecting strip L=432mm
4	1	422576	Brace for Ball valve
5	1	422582	Draught control main assembly
6	1	422646	Air filter K&N Honda GX200
7	1	422648	Ball valve 1/2inch
8	1	423415	Throttle-Choke brace
9	2	423419	Cable clamp
10	1	423444	O-ring OR6,00-1,00
11	1	423446	Joint nipple
12	2	423627	Gasket for fueltank
13	1	43356	External fuel cap
14	1	43359	Tension brace
15	1	441705	HONDA GX200UT SXE5 electrical start
16	1	58013000	Lock-nut WRG 1/2"
17	1	852520	Composite hose connector 1/2"x20ug

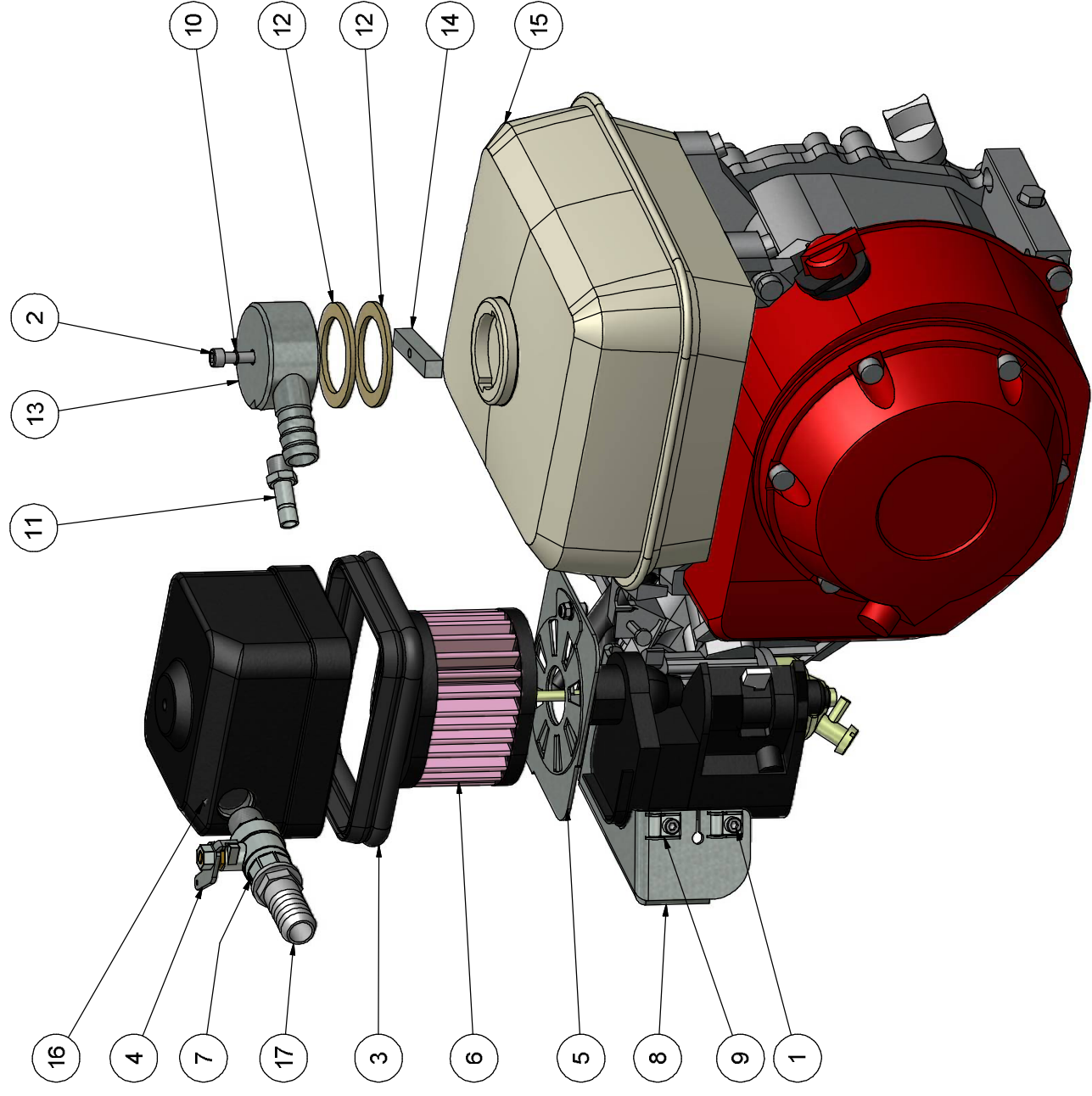

Alle kanten reifles
Breake all edges

115
Hedensted Gruppen
Part No.: 422658
Description: engine assembly 1

Scale: DS/ISO 2768-m
Material: KC
Date: 18-12-2010

Alle kanten reifles
Breake all edges

REVISION HISTORY

REV	DESCRIPTION	DATE	APPROVED
A	Made	05-01-2011	KC
B	2 gaskets and o-ring added	07-02-2012	KL

Sheet size: A3
Sheet: 1 / 1

Parts List

ITEM	QTY	PART NUMBER	DESCRIPTION
1	1	10206030	Bolt Unbraco cyl 6x30 FZB
2	2	10208020	Bolt.unbraco cyl 8x20 FZB
3	1	423528	Brace for steering cable
4	1	423530	Hydrostate pump
5	1	424047	Adjustible elbow 12L DM
6	1	424060	T-pipe screw connection Ø12-L
7	1	424080	3/4" Male mess. f. 3/4" SI
8	1	424176	L-Fitting 12L-3/8
9	1	47104	3/4" Vinkel M/M Galv
10	1	477097	Male stud 3/8" x 3/4" PP
11	1	477110	Male stud 12L 1/4"
12	1	477120	Male stud Ø15-L 1/2" DM
13	1	477141	Elbow 15L 1/2" K DM
14	1	477146	Elbow 15L 3/8"
15	1	477163	Bopnded seal washer 3/8"
16	1	477208	Steam reducer 15L 22L
17	2	477272	Male test niple 12L
18	1	489103	Ball joint AS08-M05 Formatic
19	2	82108000	Washer M8 FZB

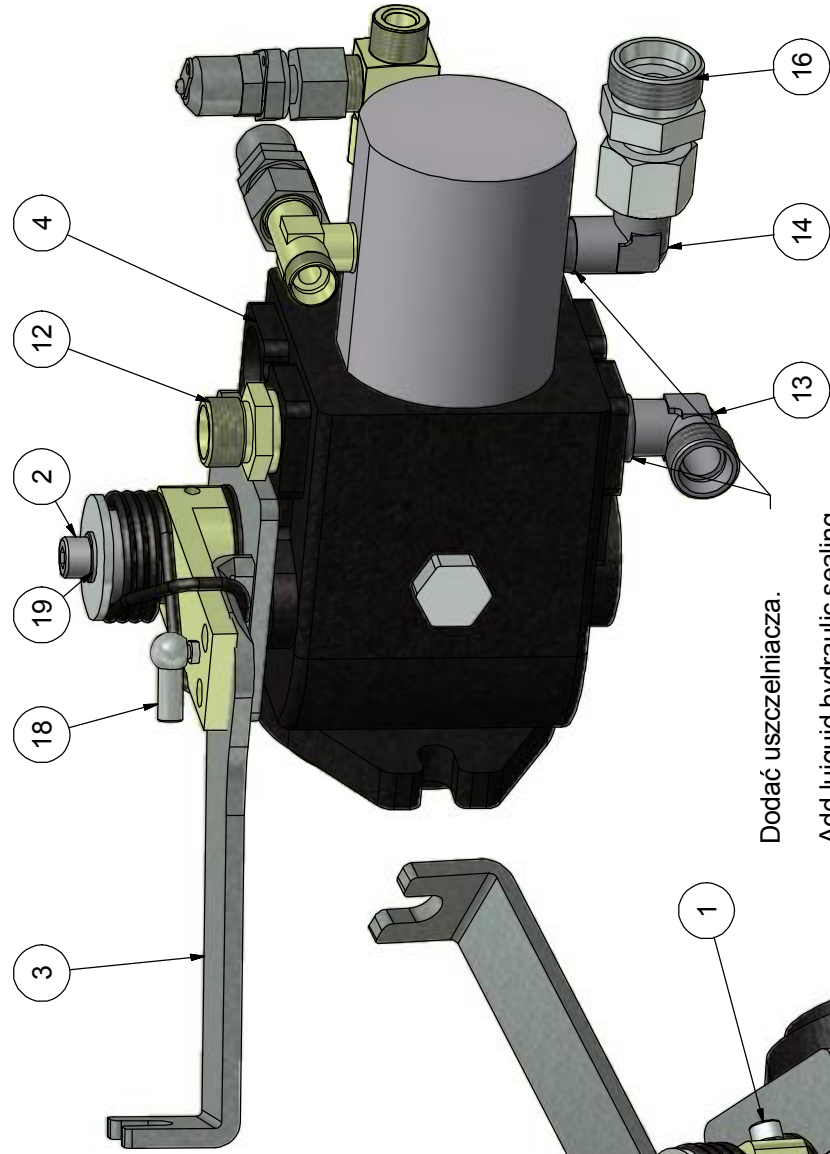

Dodać uszczelniaacza.

Add luiquid hydraulic sealing

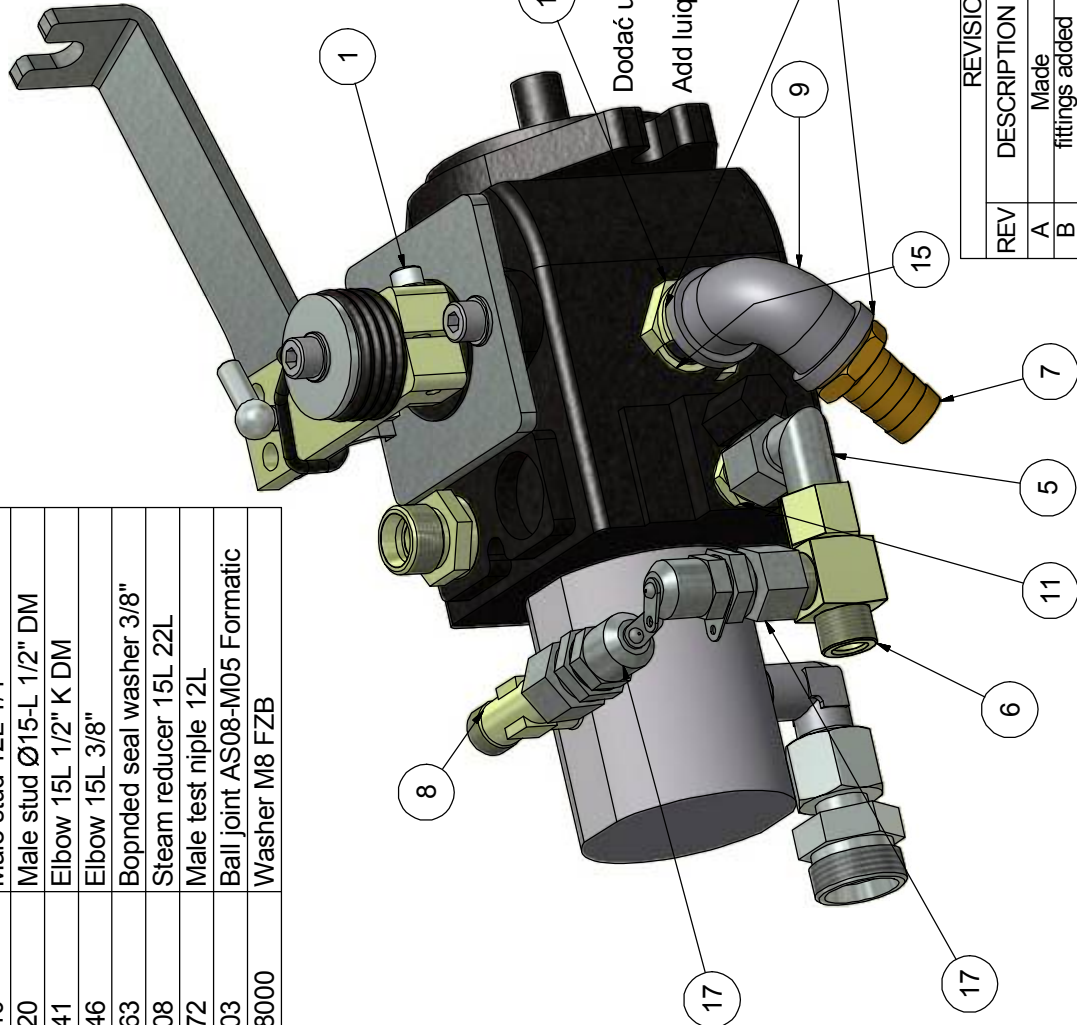

Dodać uszczelniaacza.

Add luiquid hydraulic sealing

Alle kanter reifes
Breake all edges

Scale: Note angle/tolerance fit / Not specified tolerance according to: DS/ISO 2768-m
Overfit. basket/fit/head/Surface properties: Material: Part No.: 422672 Date: 06-01-2011
Description: Hydraulic pump assembly
Scale: 1 / 2

REV	DESCRIPTION	DATE	APPROVED
A	Made fittings added	05-01-2011	KC
B	elbow fitting added	01-05-2014	MRH
C	elbow fitting added	20-08-2014	MRH

PARTS LIST

ITEM	QTY	PART NUMBER	DESCRIPTION
1	2	1508000	Nut M8 FZB
2	1	423522	Handle for tilt valve
3	1	423526	Hydraulic tilt valve
5	1	477163	Bopnded seal washer 3/8"
6	1	477222	Banjo bolt 3/8" bsp
7	3	477139	Elbow stud Ø12-L 3/8"K-DM

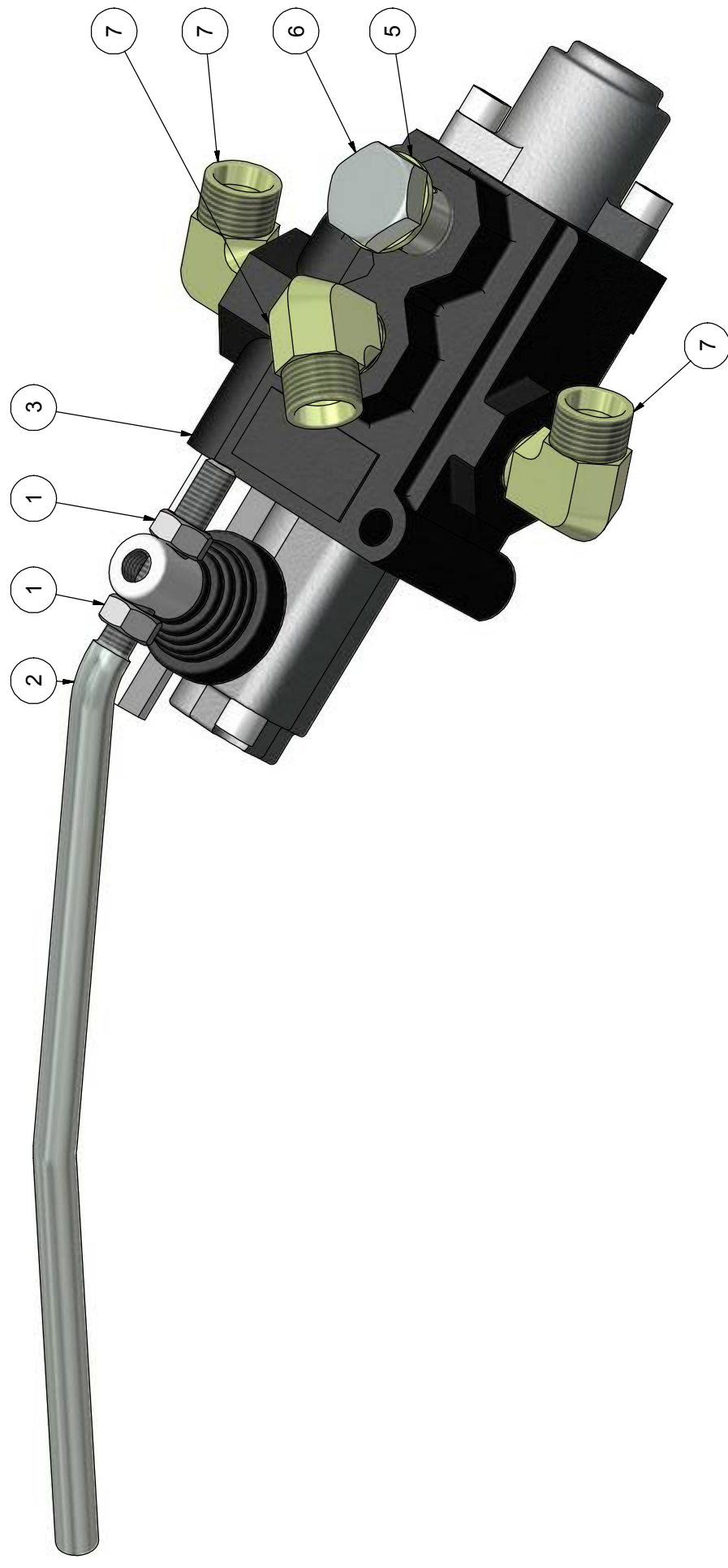

Alle kanter reifes
Breake all edges

Hedensted Gruppen
 HEDENSTED GRUPPEN A/S
 Hedehusvej 10
 DK-5230 Odense S
 Denmark
 Tel: +45 63 42 26 63
 Fax: +45 63 42 26 64
 E-mail: hgs@hgs.dk

Scale: 1:1
 DS/ISO 2768-m
 Overl. basis flæmmede overflader egenskaber:
 No
 Material:
 Part No.: 422663
 Description: Tilt valve assembly 2014
 Sheet: 1 / 2
 Sheet size: A3

REV	DESCRIPTION	DATE	APPROVED
A	Made	23-04-2014	MRH

REVISION HISTORY

Parts List

ITEM	QTY	PART NUMBER	DESCRIPTION
1	2	11408020	Hexagon bolt m8x20 FZB
2	1	422534	Bearing for handle
3	1	423423	Slide Bearing PAF 12070 P10
4	2	82108000	Washer M8 FZB

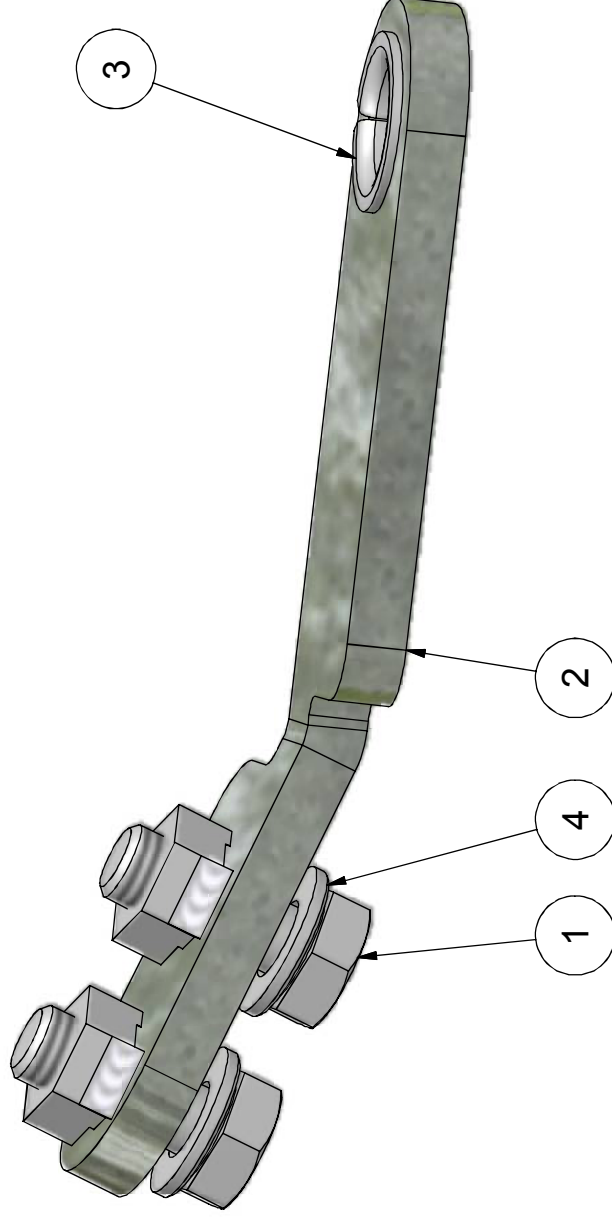

Alle kanter reifes
Breake all edges

		Scale:	Ikke angivet tolerance iht./ Not specified tolerance according to:	Konst./Designed:
Part No.: 422664			DS/ISO 2768-m	Tegnet/Drafted:
Description: Assembly bearing for handle		Undersøet iht./ Unchecked according to:	Overfl. beskaffenhed/Surface properties:	KC
Description:		Material:	Date:	04-01-2011
This document is strictly confidential and must not be accounted for copied or disclosed to any third person. HEDENSTED GRUPPEN A/S				
REV	DESCRIPTION	DATE	APPROVED	
A	Made	04-01-2011	kc	
Siden gemt/Last saved by: KC		Siden gemt/Last saved: 04-01-2011	Sheet size: A4	Sheet 1 / 1

REVISION HISTORY

Bend the plate so it works as stops for the handles

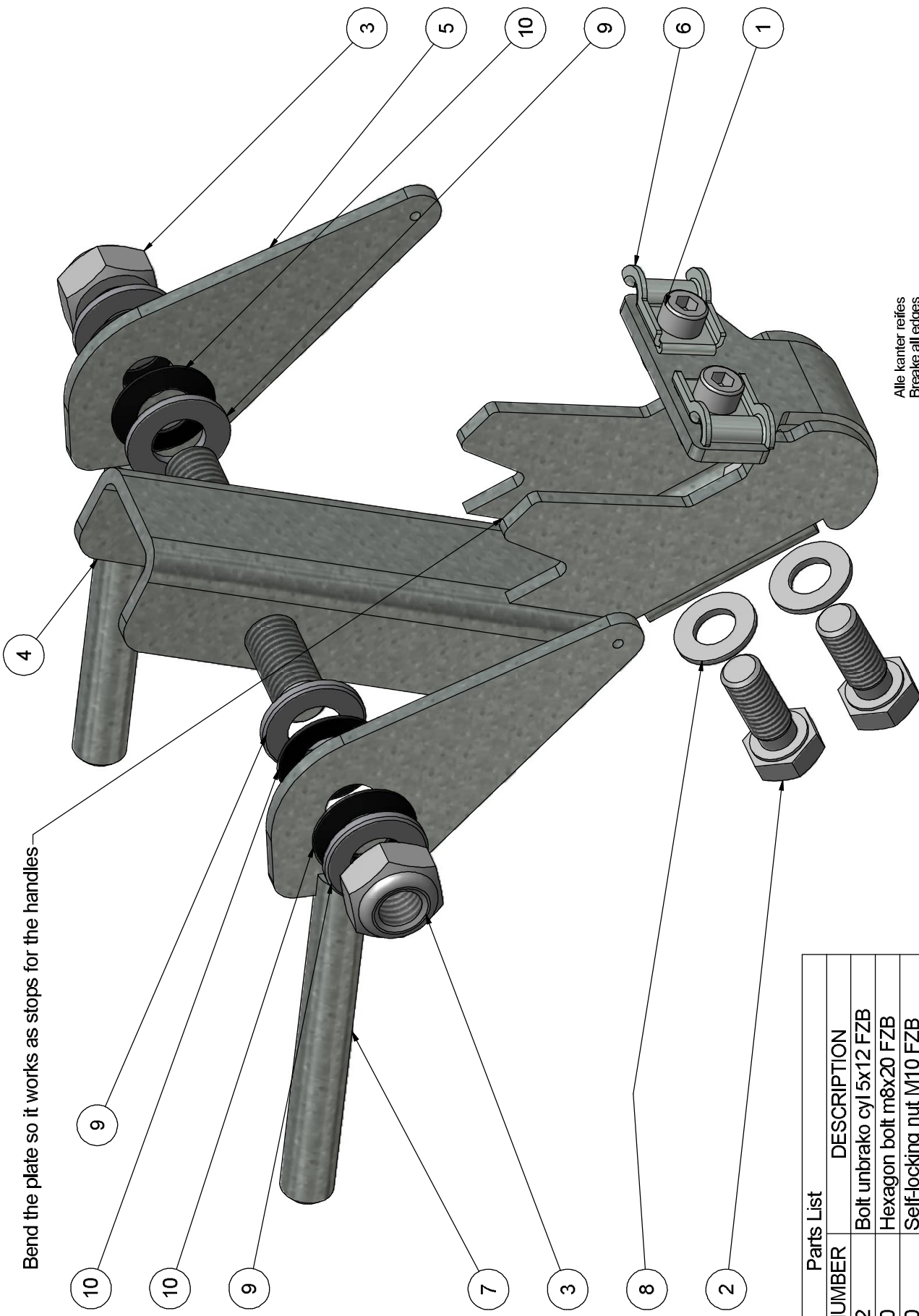

Parts List

ITEM	QTY	PART NUMBER	DESCRIPTION
1	2	10205012	Bolt unbrako cyl 5x12 FZB
2	2	11408020	Hexagon bolt m8x20 FZB
3	2	17910000	Self-locking nut M10 FZB
4	1	423412	Brace for throttle and choke
5	1	423413	Gas choke handle right
6	2	423419	Cable clamp
7	1	423426	Gas choke handle left
8	2	82108000	Washer M8 FZB
9	4	82110000	Washer M10 FZB
10	4	89310080	Disc spring 20x10,3x0,8 black

REV	DESCRIPTION	DATE	APPROVED
A	Made	06-01-2011	KC
B	Disc spring added	06-02-2012	KL

Alle kanter reifes
Breake all edges

HGS
Hedensted Gruppen
Part No.: 422666
Description: Throttle/Choke assembly



Scale: Make any tolerances for fit / for special tolerances according to: DS/ISO 2768-m
Overfit, backlash and surface properties:
Material: Variable marking according to: Material:
Date: 10-02-2009

The drawing is only correct as printed
Alle Rechte vorbehalten
HEDENSTED GRUPPEN A/S
Sheet part of assembly: KC Sheet part of assembly: A3 Sheet size: A3 Sheet: 1 / 1

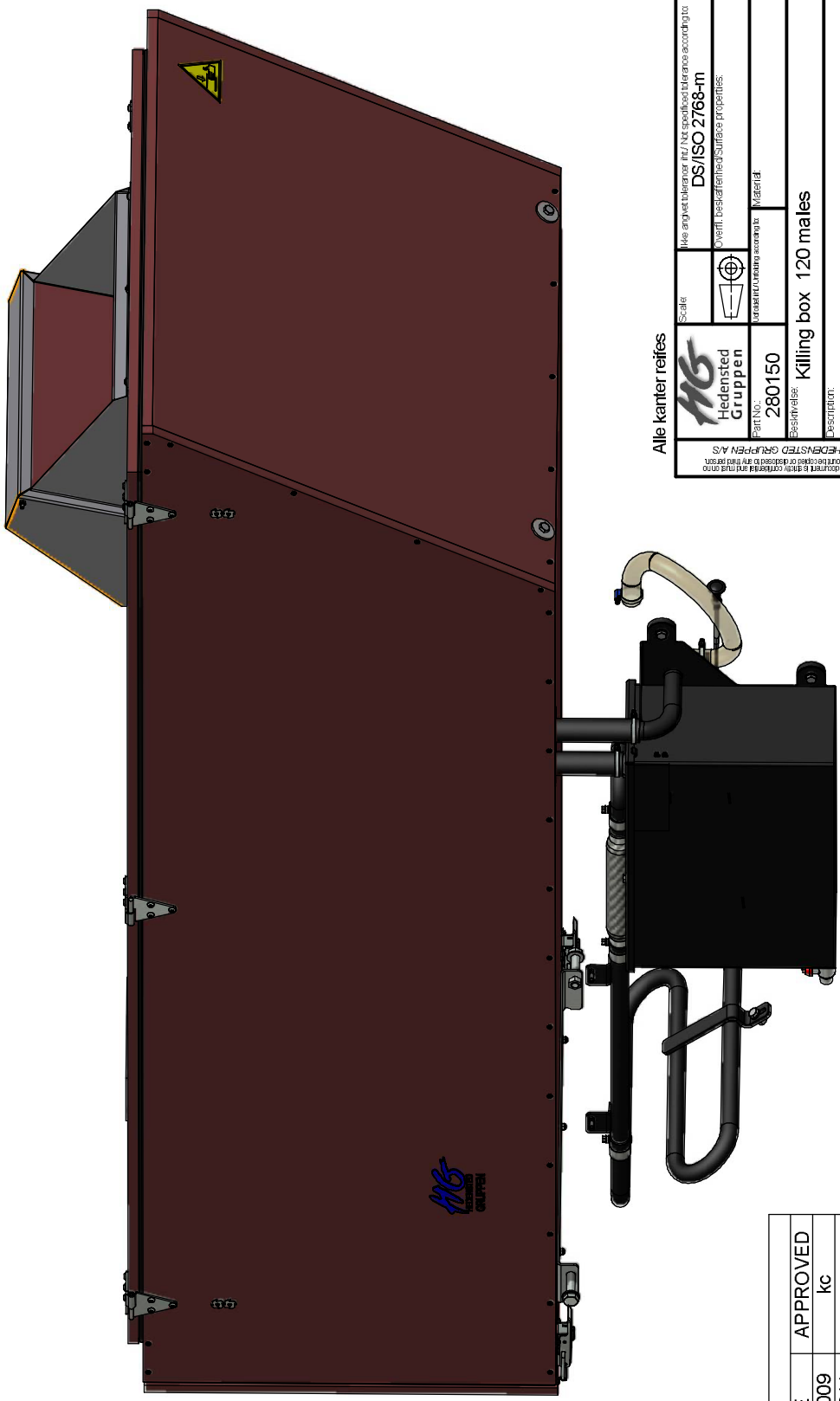
Parts List			Parts List				
ITEM	QTY	PART NUMBER	DESCRIPTION	ITEM	QTY	PART NUMBER	DESCRIPTION
1	2	11406012	Hexagon bolt M6x12 FZB	11	1	422638	Killing box
2	1	11406025	Hexagon bolt M6x25 FZB	12	1	470565	Choke cable SS-SM
3	1	11408020	Hexagon bolt M8x20 FZB	13	2	474008	Hose clamp 22-30
4	4	11408025	Hexagon bolt M8x25 FZB	14	4	474010	Hose clamp 25-35
5	2	11412055	Hexagon bolt 12 x 55 FZB	15	1	477572	Alfasteel hose Ø20 L= 530mm
6	3	1508000	Nut M8 FZB	16	2	4809335	Washer type SRKB ø9x35x3
7	1	422506	Filter box main assembly	17	2	82106000	Washer M6 FZB
8	1	422572	Exhaust system for killing box	18	5	82108000	Washer M8 FZB
9	2	422636	Heat hose 1 inch L= 165mm	19	2	82112000	Washer M12 FZB
10	1	422636_	Heat hose 1 inch L= 920mm	20	3	423439	HG Logo 75x110



Alle kanter reifies

 Hedensted Gruppen	Scale	Make any modifications to the drawing according to:	Construct/Designed by
		DS/ISO 2768-m	egnat/Checked
Part No.: 280150	Verify basket finish/surface properties:	Material:	Date: 30-06-2009
Bestillingsnr: Killing box 120 males Description:	Material:	Sheet part of assembly: KC	Sheet size: A3
The drawing is only correct and valid if you have received the drawing from the HEDENSTED GRUPPEN AS.			Sheet 1 / 1

REVISION HISTORY			
REV	DESCRIPTION	DATE	APPROVED
A	Made	14-07-2009	Kc
B	Renamed	18-01-2011	
C	Parts Removed	13-12-2013	MAC

Parts List

ITEM	QTY	PART NUMBER	DESCRIPTION
1	4	10203008	Bolt Unbraco cyl 3x08 FZB
2	2	11406030	Hexagon bolt M6x30 FZB
3	4	17903000	Self-locking nut M3 FZB
4	2	17906000	Self-locking nut M6 FZB
5	1	422508	Filter box assembly 1
6	1	422510	Filter box assembly 2
7	1	422511	Polyester filter PPI20
8	2	422554	Mini Latch
9	1	422644	Gasket for filterbox
10	1	477527	1/4" Ball valve male/female
11	2	4809335	Washer type SRKB ø9x35x3
12	4	82103000	Washer M3 FZB

Glue gasket to lid with scilicone

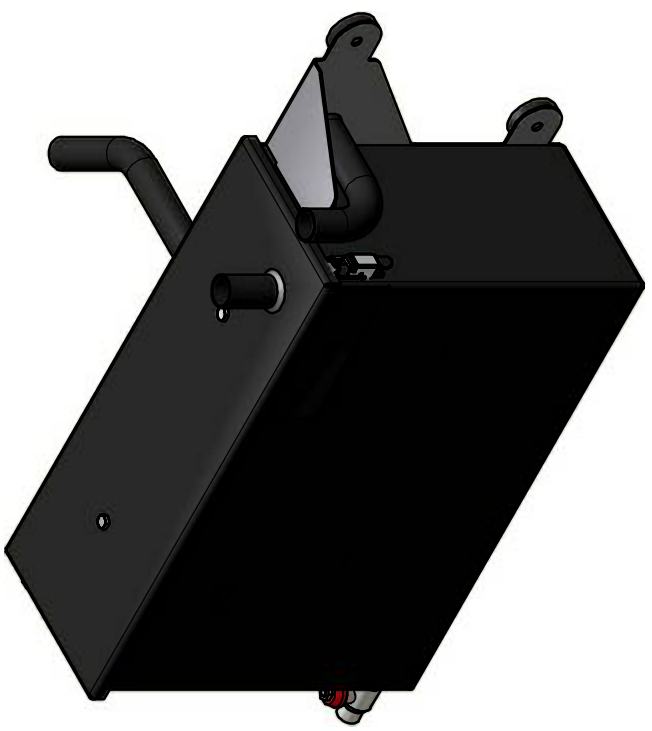
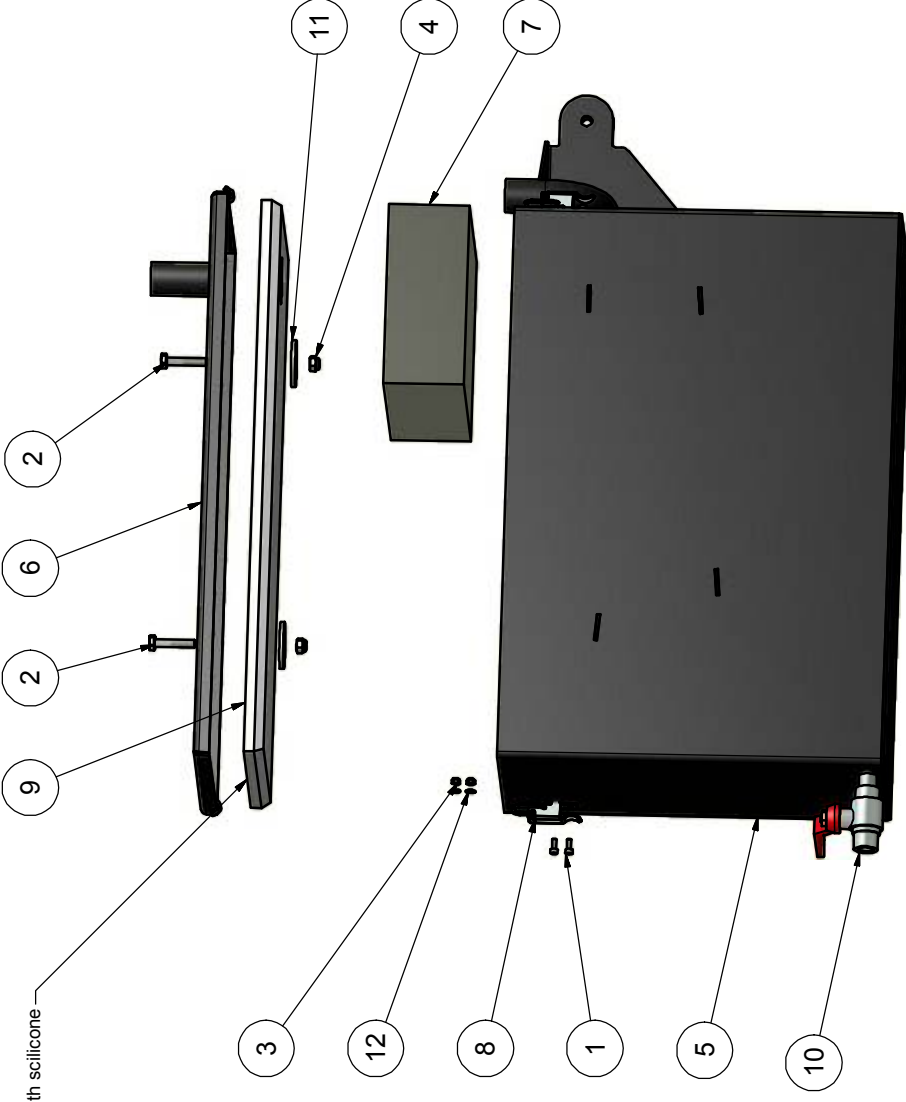

Alle kanten reifes

Heddensted Gruppen
 Part No.: 422508
 Description: Filter box main assembly
 Scale: DS/ISO 2768-m
 Material: DS/ISO 2768-m
 Date: 07-11-2008
 Sheet size: A3
 Sheet: 1 / 1

REV	DESCRIPTION	DATE	APPROVED
A	Made	07-11-2008	KC
B	Rubber sealing added	16-09-2009	KC
C	Renamed	17-01-2011	KC
D	Gasket/valve changed	17-02-2012	KL
E	Part List updated	19-09-2014	KC
F	1 filter removed	16-11-2014	KL

Parts List

ITEM	QTY	PART NUMBER	DESCRIPTION
1	4	11408025	Hexagon bolt M8x25 FZB
2	13	140852	Woodscrew countersunk head 3,5x35
3	31	140872	Wood screw 5x16
4	6	140875	Countersunk wood screw 5x20 FZB PZ2
5	10	17905000	Self-locking nut M5 FZB
6	4	17908000	Self-locking nut M8 FZB
7	23	19205000	Bracket nut M5
8	1	280160	Hatch assembly complete
9	1	31009	Warning sign. Crushing
10	1	41442	Box part 4
11	1	41446	Box part 6
12	2	41447	Box part 7
13	1	422500	Brace for stand
14	3	422518	Hinge right
15	2	422520	Hinge left
16	1	422531	Box for killing box
17	1	422570	Exhaust-intake for killing box
18	1	422596	Window for killing box
19	4	422598	Wether strip 1
20	2	422600	Wether strip 2
21	2	422602	Wether strip 3
22	3	422604	Latch with lock
23	3	422606	Brace for latch
24	4	422608	Brace for gas spring
25	2	422610	Gas spring 250N 200mm
26	4	422612	Eye joint for gas spring
27	6	64405025	Cup head square neck bolt M5x25 FZB
28	42	76005020	Bolt buttonhead 5x20 FZB
29	6	82105900	Washer M5 FZB
49	1	M100151	Tension brace for Hydra combi
51	1	M100150	Cover plate
52	2	M10249	Handle part 2
53	1	M100141	Angle for clamp- hydra combi
54	1	M100840	Tension brace for hydra combi
55	1	423424	Cab for handle
56	4	76005016	Bolt buttonhead 5x15 FZB
58	4	11405012	Hexagon bolt M5x12 FZB
59	4	82605000	Washer 5,3x15mm FZB

422500 may first be mounted when it's placed on the stand

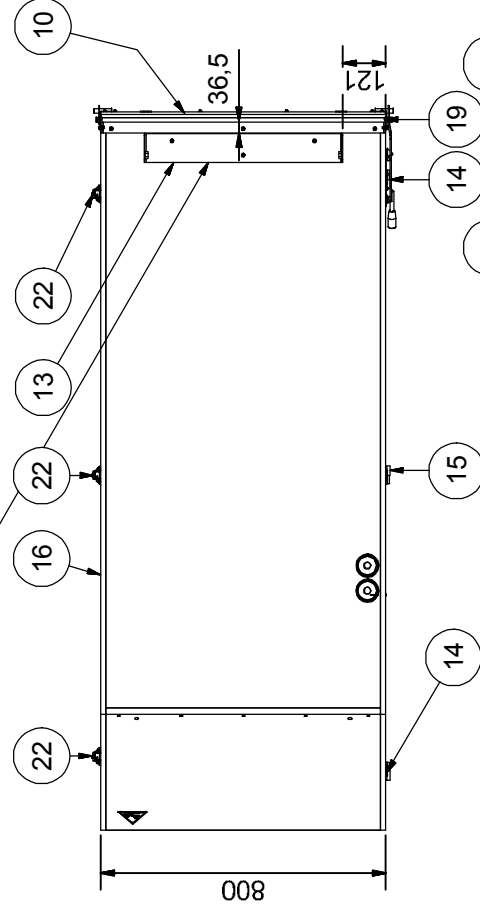
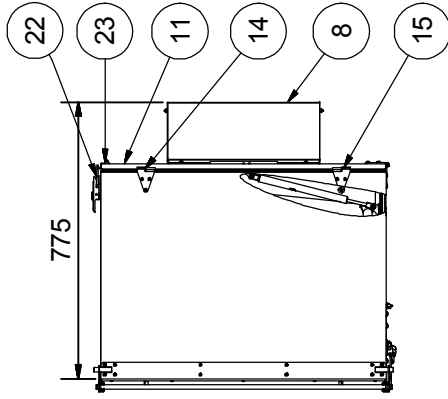

Drill Ø3,5 holes and make countersunk for all screws

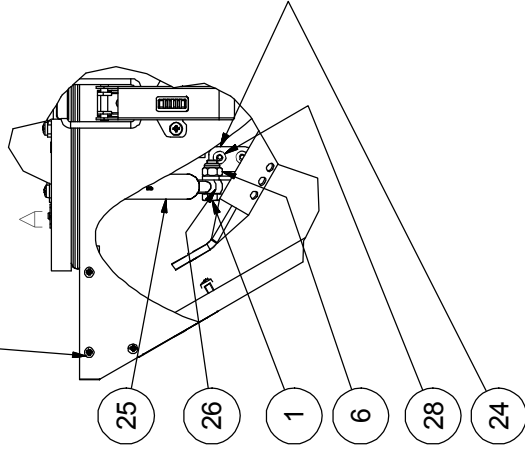

All edges, corners and gabs must be sealed with silicone
All edges on the wood must be painted brown

Alle kanter reifes

REV	DESCRIPTION	DATE	APPROVED
A	Made	01-07-2009	KC
B	Parts added	30-08-2010	KC
C	Part added	05-10-2011	KC
D	Hinge system changed	16-11-2014	KL

Scale: Make angles/ tolerances fit / Not specified tolerance according to: DS/ISO 2768-m
Overfit, basket/length/Surface, properties: Material: Date: 23-01-2009

Part No.: 422638
Beschreibung: Killing box
Description: Killingbox
Scale: part list/assembly: KC
Sheet size: A3
Sheet: 1 / 3

Parts List

ITEM	QTY	PART NUMBER	DESCRIPTION
1	4	11408025	Hexagon bolt M8x25 FZB
2	13	140852	Woodscrew countersunk head 3,5x35
3	31	140872	Wood screw 5x16
4	6	140875	Countersunk wood screw 5x20 FZB PZ2
5	10	17905000	Self-locking nut M5 FZB
6	4	17908000	Self-locking nut M8 FZB
7	23	19205000	Bracket nut M5
8	1	280160	Hatch assembly complete
9	1	31009	Warning sign. Crushing
10	1	41442	Box part 4
11	1	41446	Box part 6
12	2	41447	Box part 7
13	1	422500	Brace for stand
14	3	422518	Hinge right
15	2	422520	Hinge left
16	1	422531	Box for killing box
17	1	422570	Exhaust-intake for killing box
18	1	422596	Window for killing box
19	4	422598	Wether strip 1
20	2	422600	Wether strip 2
21	2	422602	Wether strip 3
22	3	422604	Latch with lock
23	3	422606	Brace for latch
24	4	422608	Brace for gas spring
25	2	422610	Gas spring 250N 200mm
26	4	422612	Eye joini for gas spring
27	6	64405025	Cup head square neck bolt M5x25 FZB
28	42	76005020	Bolt buttonhead 5x20 FZB
29	6	82105900	Washer M5 FZB
49	1	M100151	Tension brace for Hydra combi
51	1	M100150	Cover plate
52	2	M10249	Handle part 2
53	1	M100141	Angle for clamp- hydra combi
54	1	M100840	Tension brace for hydra combi
55	1	423424	Cab for handle
56	4	76005016	Bolt buttonhead 5x15 FZB
58	4	11405012	Hexagon bolt M5x12 FZB
59	4	82605000	Washer 5,3x15mm FZB

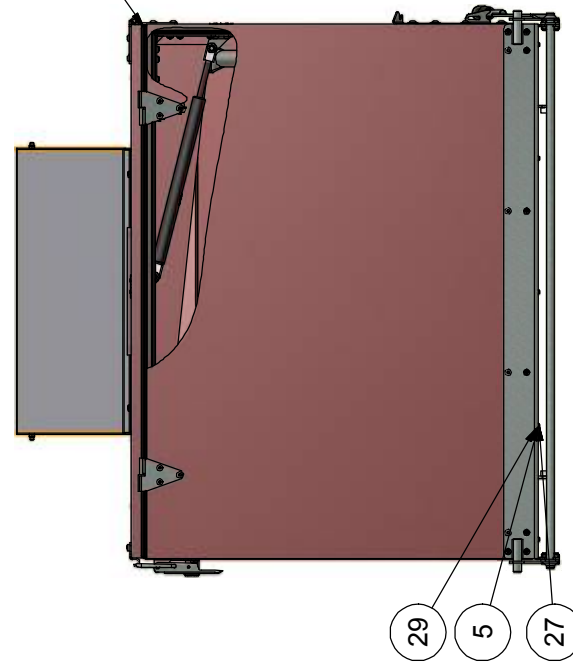
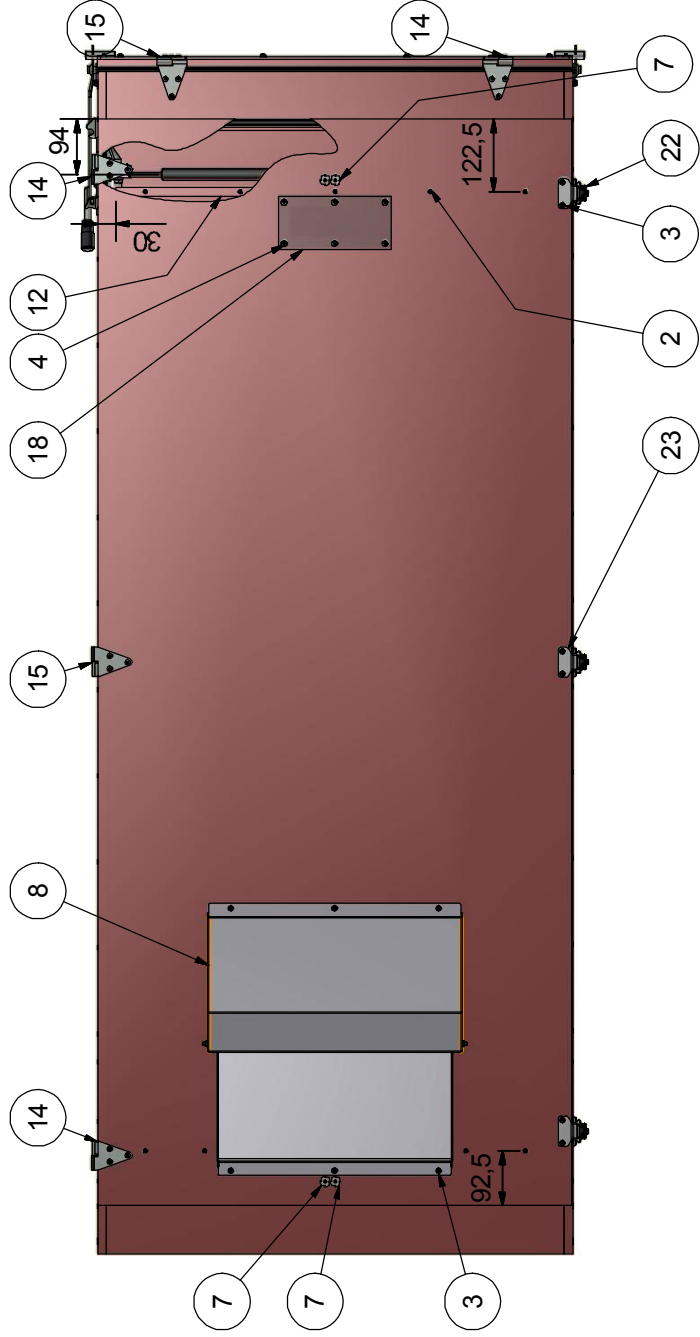

Use zinc plated clamps to fasten rubber sealings

Alle kanter reifies

Scale: 1:1
 Make angle tolerances fit / Not specified tolerances according to: DS/ISO 2768-m
 Overfit, basket/tenet/Surface properties:
 Material: 422638
 Date: 23-01-2009
 Description: Killing box
 Part No.: 422638
 Material: 422638
 Date: 23-01-2009
 Sheet size: A3
 Sheet: 2 / 3

Adjust to 23,5mm when mounting

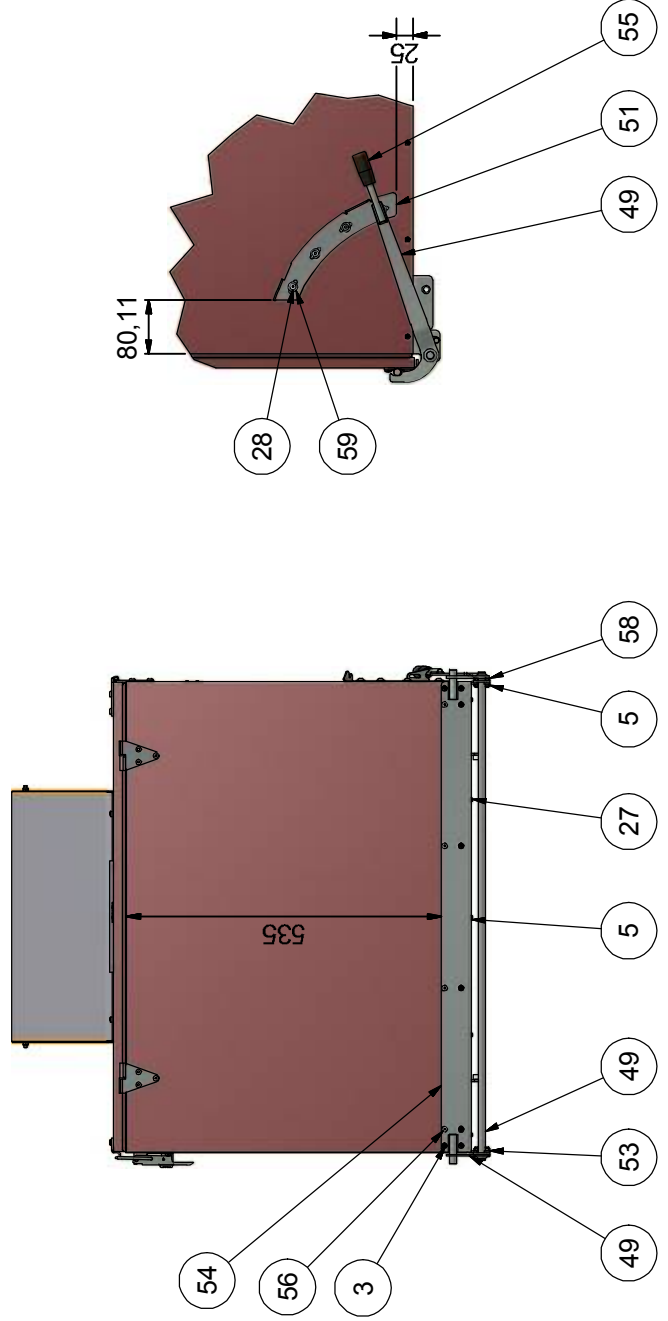
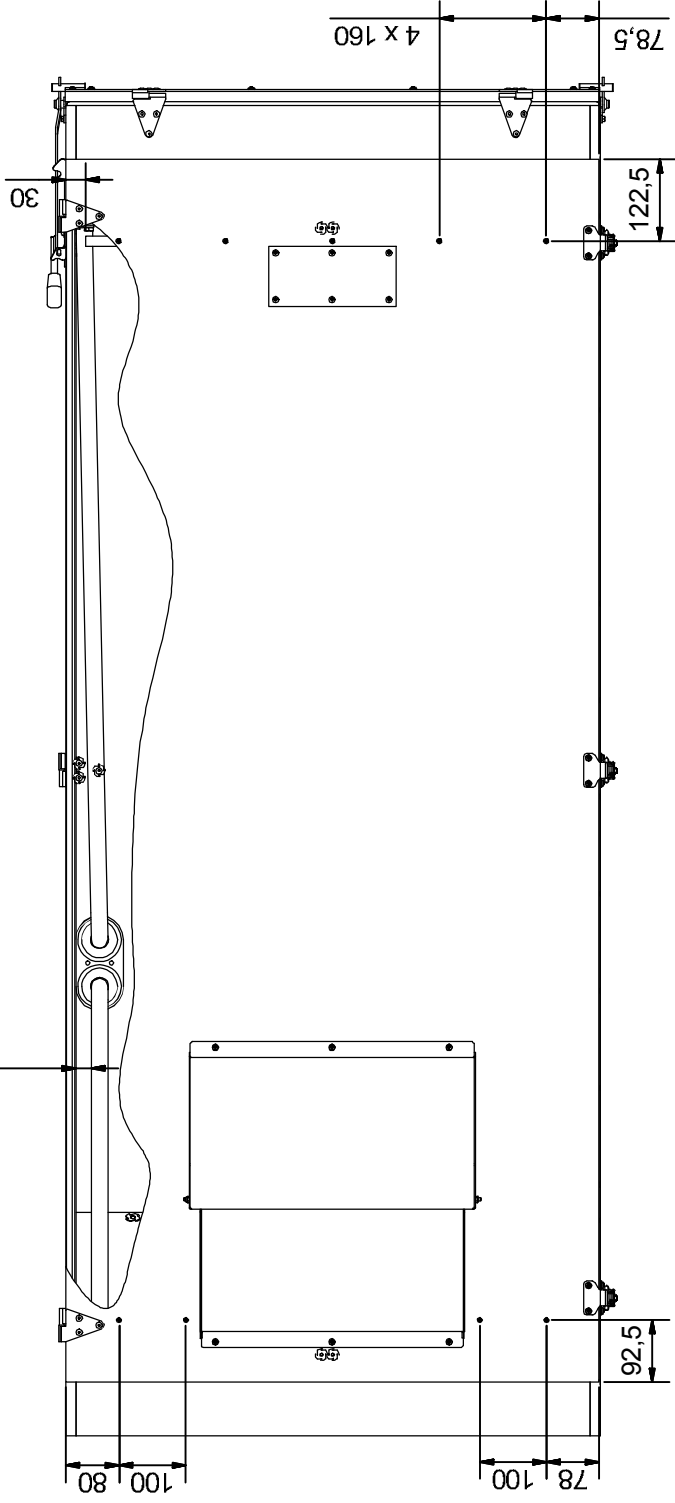

Alle kanter reifies

Scale:		Alle angivet toleranser til / Not specified tolerances according to:	
Hedensted Gruppen		DS/ISO 2768-m	
Part No.:		Overfl. basker/enhed/Surface properties:	
422638		Material:	
Beskriver:		Date:	
Killing box		23-01-2009	
Description:			
The document is a safety-critical technical drawing and must be used in accordance with the applicable standards and regulations.			
HEDENSTED GRUPPEN A/S			
Scale: 1:1			
Material: 422638			
Date: 23-01-2009			
Sheet size: A3			
Sheet 3 / 3			

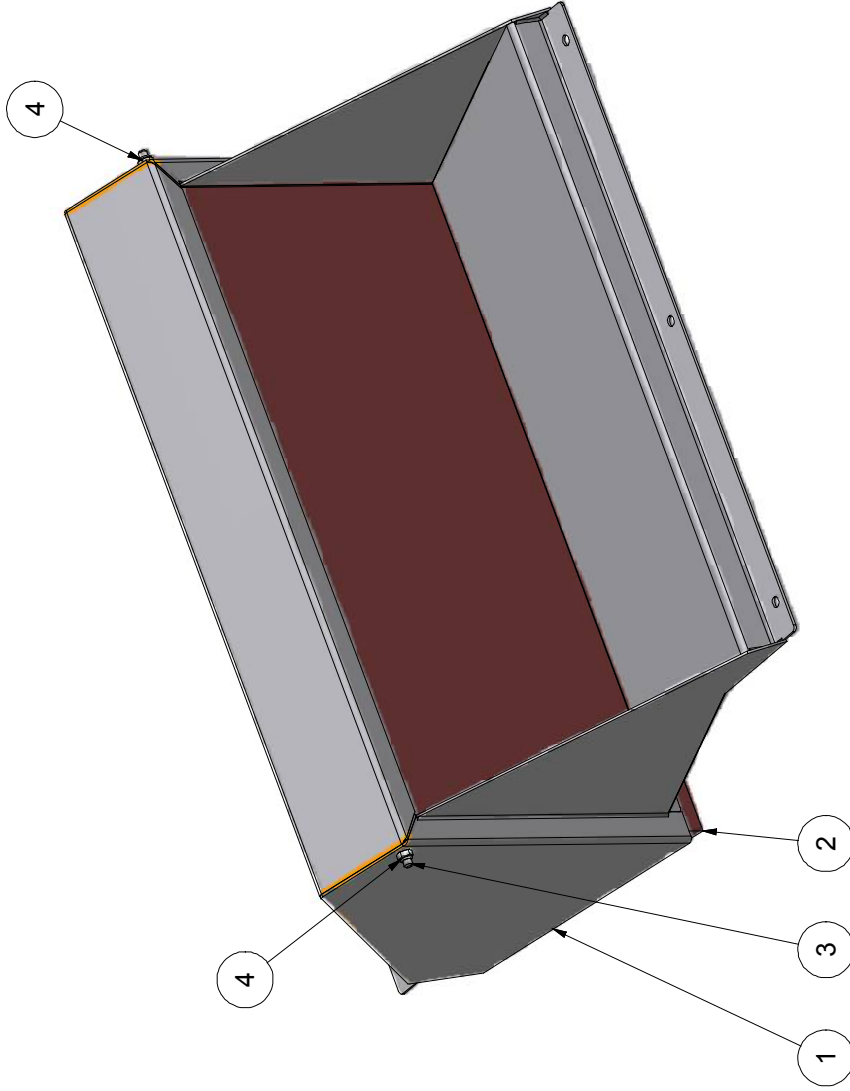

Alle kanten reifes

Parts List	
ITEM QTY	PART NUMBER DESCRIPTION
1	422590 Mail box assembly 1
2	422592 Mail box assembly 2
3	422588 Thread rod for mail box
4	17905000 Self-locking nut M5 FZB

REVISION HISTORY		
REV	DESCRIPTION	DATE
A	Made	26-06-2009
B	Renamed and new partnumber	08-07-2010
		APPROVED
		KC
		KC

Scale:		Alle angivne dimensioner i 1/1. Not specified dimension according to:		Konst./Designed:
Hedensted Gruppen		DS/ISO 2768-m		Regne/Drawn:
Part No.: 280160		Overfl. beskaffenhed/Surface properties:		Date:
Beskrivelse: Hatch assembly complete		Udsættelse/Uncoating according to: Material:		28-10-2008
Description:		Kontrollant/checked by: KC		26-06-2009
Sheet number/total sheet: 1 / 1		Sheet size: A3		Sheet 1 / 1

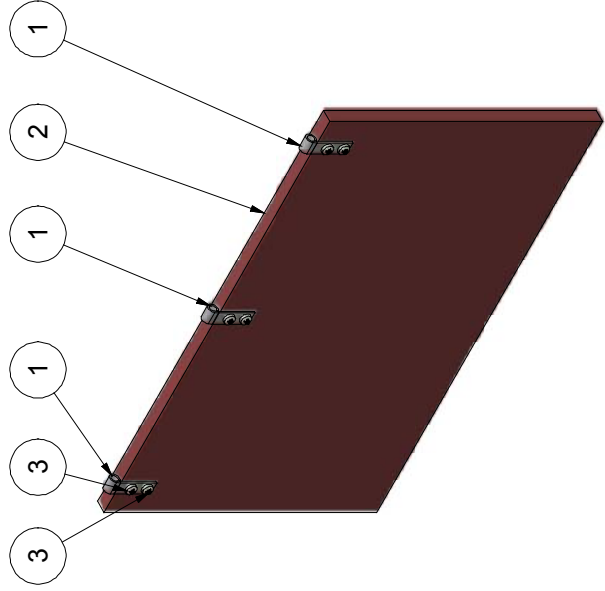
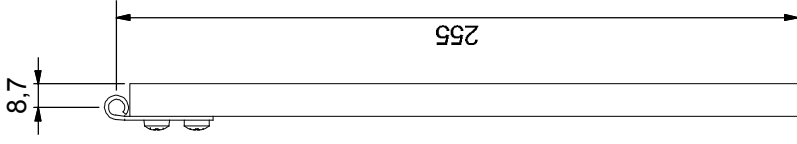

Parts List

ITEM	QTY	PART NUMBER	DESCRIPTION
1	4	422584	Hinge for mail box
2	1	422586	Lid for mail box
3	6	64850012	Wood screw panhead Ø5x12

Scale:	None angivel tolerances in / Not specified tolerances according to:	Konst./Designed:
	DS/ISO 2768-m	
Part No.:	422592	Region/Drawn:
		Kc
Material:		Date:
		28-10-2008

Revision:		Mail box assembly 2	
Description:			
REV	DESCRIPTION	DATE	APPROVED
A	Made	26-06-2009	Kc
B	Renamed	13-01-2011	Kc

Part No.:	422592	Region/Drawn:	Kc
Material:		Date:	28-10-2008
Scale:		Konst./Designed:	
		Region/Drawn:	
		Date:	
		28-10-2008	
Part No.:	422592	Region/Drawn:	Kc
Material:		Date:	28-10-2008
Scale:		Konst./Designed:	
		Region/Drawn:	
		Date:	
		28-10-2008	

Part No.:	422592	Region/Drawn:	Kc
Material:		Date:	28-10-2008
Scale:		Konst./Designed:	
		Region/Drawn:	
		Date:	
		28-10-2008	