

LPL Series-Long Standby Life LPL6-6.5(6V6.5Ah)



Specifications

Rated Voltage	6V	
Nominal Capacity	(C ₂₀ , 1.75V/cell)	6.5Ah
Dimension	Length	151±2mm (5.94 inches)
	Width	34±1mm (1.34 inches)
	Container Height	94±1mm (3.70 inches)
	Total Height	100±2mm (3.94 inches)
Approx Weight	1.26 Kg (2.78 lbs)	
Terminal	T1/T2	
Container Material	ABS	
Rated Capacity (25°C)	6.50 Ah	(20hr,0.325A,1.75V/cell)
	6.46 Ah	(10hr,0.646A,1.75V/cell)
	6.40 Ah	(5hr,1.28A,1.75V/cell)
	5.76 Ah	(3hr,1.92A,1.75V/cell)
	4.88 Ah	(1hr,4.88A,1.60V/cell)
Max. Discharge Current	97.5A (5s)	
Internal Resistance (25°C)	Approx 20mΩ	
Operating Temp.Range	Discharge	-15 ~ 50°C (5 ~ 122°F)
	Charge	-20 ~ 40°C (-4 ~ 104°F)
	Storage	-15 ~ 40°C (5 ~ 104°F)
Nominal Operating Temp. Range	25±3°C (77±5°F)	
Cycle Use	Initial Charging Current less than 1.95A. Voltage 7.2V~7.5V at 25°C(77°F)Temp. Coefficient -15mV/°C	
Standby Use	Initial Charging Current less than 1.95A. Voltage 6.75V~6.90V at 25°C(77°F)Temp. Coefficient -10mV/°C	
Effect of temp. to Capacity	40°C (104°F)	103%
	25°C (77°F)	100%
	0°C (32°F)	86%
Self Discharge	LPL series batteries may be stored for up to 6 months at 25°C(77°F) and then a freshening charge is required. For higher temperatures the time interval will be shorter.	



Layout

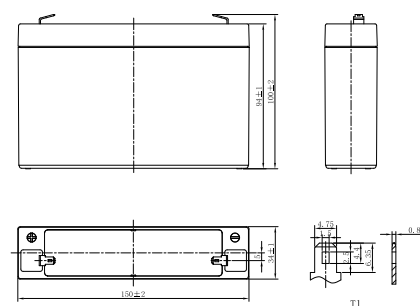

Constant Current Discharge (Amperes) at 25 °C (77°F)

F.V/Time	10min	15min	20min	30min	45min	1h	2h	3h	4h	5h	6h	8h	10h	20h
1.85V/cell	15.5	12.3	10.0	7.46	5.48	4.47	2.60	1.86	1.47	1.24	1.04	0.782	0.631	0.318
1.80V/cell	16.3	12.8	10.3	7.65	5.58	4.56	2.64	1.89	1.49	1.26	1.06	0.792	0.638	0.322
1.75V/cell	17.1	13.2	10.6	7.83	5.70	4.64	2.68	1.92	1.51	1.28	1.07	0.802	0.646	0.325
1.70V/cell	17.9	13.7	11.0	8.01	5.80	4.72	2.72	1.95	1.53	1.29	1.08	0.811	0.654	0.328
1.65V/cell	18.4	14.0	11.2	8.12	5.87	4.77	2.74	1.96	1.54	1.30	1.09	0.818	0.658	0.330
1.60V/cell	19.5	14.6	11.6	8.37	6.03	4.88	2.80	2.00	1.57	1.33	1.11	0.831	0.669	0.335

Constant Power Discharge (Watts/cell) at 25 °C (77°F)

F.V/Time	10min	15min	20min	30min	45min	1h	2h	3h	4h	5h	6h	8h	10h	20h
1.85V/cell	29.7	23.6	19.3	14.4	10.6	8.70	5.08	3.66	2.90	2.46	2.06	1.55	1.25	0.637
1.80V/cell	31.0	24.4	19.8	14.7	10.8	8.84	5.15	3.71	2.93	2.49	2.08	1.57	1.27	0.643
1.75V/cell	32.3	25.2	20.3	15.0	11.0	8.96	5.21	3.76	2.97	2.52	2.11	1.59	1.28	0.650
1.70V/cell	33.6	25.9	20.8	15.3	11.1	9.09	5.28	3.80	3.00	2.54	2.13	1.60	1.30	0.657
1.65V/cell	34.4	26.4	21.1	15.4	11.2	9.17	5.32	3.83	3.02	2.56	2.15	1.62	1.30	0.661
1.60V/cell	36.2	27.4	21.8	15.8	11.5	9.34	5.41	3.90	3.07	2.60	2.18	1.64	1.32	0.670

LPL Series-Long Standby Life

LPL6-6.5(6V6.5Ah)



Applications

- UPS and EPS
- Emergency light
- Railway signal and aircraft signal system
- Marine and power stations
- Alarm and security system
- Electronic apparatus and equipment
- Communication power supply, DC power supply

General Features

- 10 ~ 12 years design life(20°C)
- Grid refining technology and the thicker plates are used to extend the battery standby life and reduce the plate grid corrosion speed
- Using oxygen recombination technology: maintenance-free
- Unique vent valve design: control water losing, prevent air and spark going inside

Standards

- Compliance with IEC 60896 standards, EU Battery Directive
- UL Certified

Discharge Characteristics

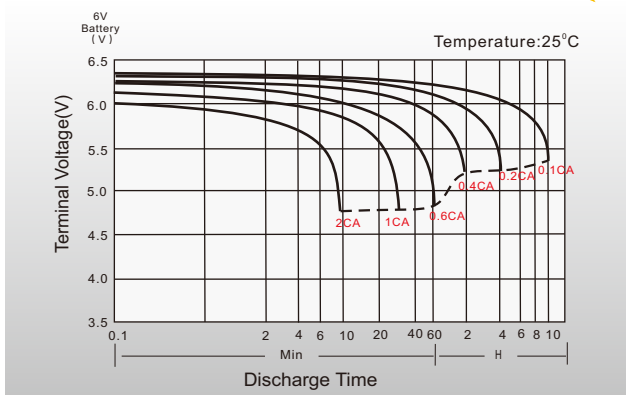

Float Charging Characteristics

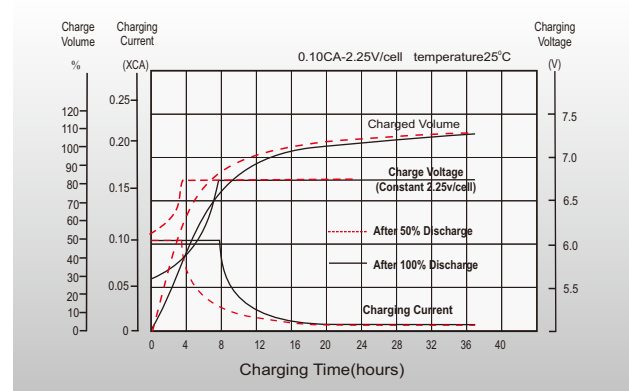

Temperature Effects in Relation to Battery Capacity

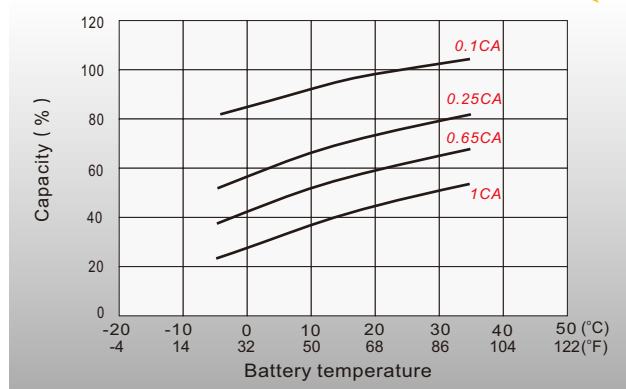

Effect of Temperature on Long Term Float Life

