



PRODUCTS

CATALOGUE

CBHD SERIES

Single-phase battery chargers

High frequency system with advanced technology

Lightweight & compact

Essential design

Universal input voltage 100 Vac ÷ 240 Vac,
50 Hz ÷ 60 Hz

Voltage 12V or 24V

On-board or stand-alone use

High efficiency

Charging process fully controlled by
microprocessor

Suitable for Lead-Acid, Sealed and Gel
Traction batteries

Customizable charging curves

Remote LED option

Data recording option

CURRENT					
12 V	2,5 A 5 A	8 A 10 A	13 A	15 A 20 A	25 A
24 V	2,5 A 5 A	8 A 10 A	13 A	15 A 20 A	25 A

■ **CBHD1 COMPACT**

■ **CBHD1 SMALL**

■ **CBHD1-XR-P**
■ **CBHD1-XR-M**

■ **CBHD2**

■ **CBHD3**





CBHD1 COMPACT

Main features:

Reduced weight and dimensions

Power from 30W up to 120W

Current from 2,5A to 5A

Available with Led on side or Led on top

APPLICATIONS



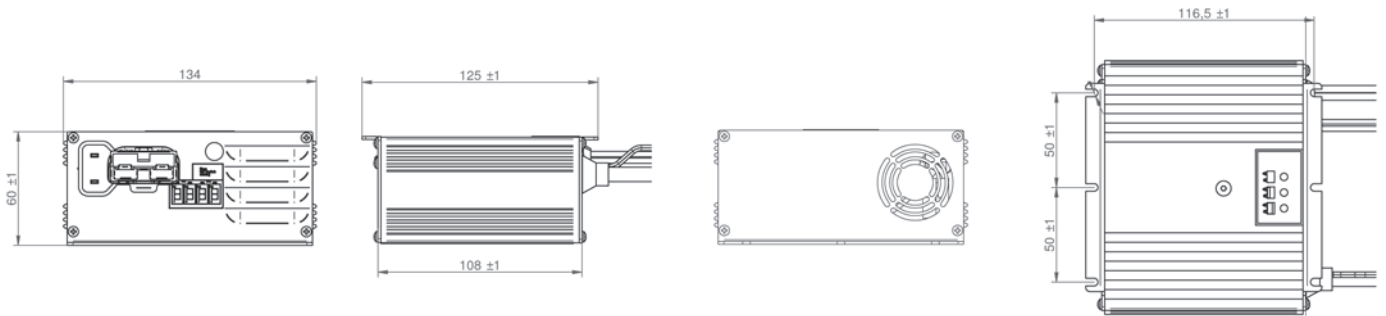

DIMENSIONS (LxWxH): 134x125x60 mm - 5.28x4.92x2.36 in
 WEIGHT: 1,20 Kg - 2.65 lbs
 PROTECTION GRADE IP30
 INPUT VOLTAGE: Universal 100 ÷ 240 Vac – 50-60 Hz

Battery Voltage	Battery Range		Charging Current	Model
	5h	20h		
12V	10÷25 Ah	15÷30 Ah	2,5A	12-2,5
	20÷50 Ah	30÷60 Ah	5A	12-5
24V	10÷25 Ah	15÷30 Ah	2,5A	24-2,5
	20÷50 Ah	30÷60 Ah	5A	24-5





CBHD1 SMALL

Main features:

Reduced weight and dimensions

Power from 30W up to 120W

Current from 8A to 10A

Available with Led on side or Led on top

APPLICATIONS



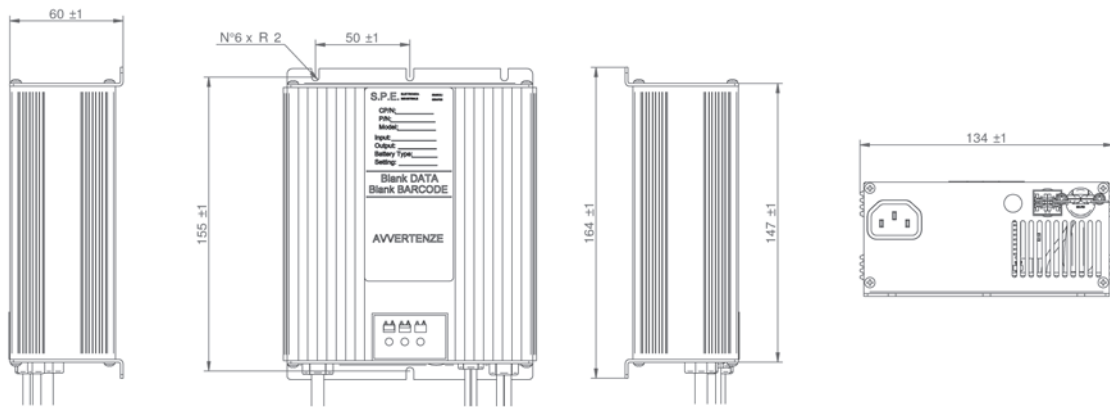

DIMENSIONS (LxWxH): 134x164x60 mm – 5.28x6.46x2.36 in
 WEIGHT: 1,80 Kg - 3.97 lbs
 PROTECTION GRADE IP30
 INPUT VOLTAGE: Universal 100 ÷ 240 Vac – 50-60 Hz

Battery Voltage	Battery Range		Charging Current	Model
	5h	20h		
12V	40 ÷ 80 Ah	60 ÷ 105 Ah	8A	12-8
	60 ÷ 100 Ah	70 ÷ 130 Ah	10A	12-10
24V	40 ÷ 80 Ah	60 ÷ 105 Ah	8A	24-8
	60 ÷ 100 Ah	70 ÷ 130 Ah	10A	24-10





CBHD1-XR-P

Main features:

Advanced and innovative resonant technology

Power from 95W up to 360W

Current from 8A to 13A

Active PFC

Available in plastic and aluminum case

APPLICATIONS



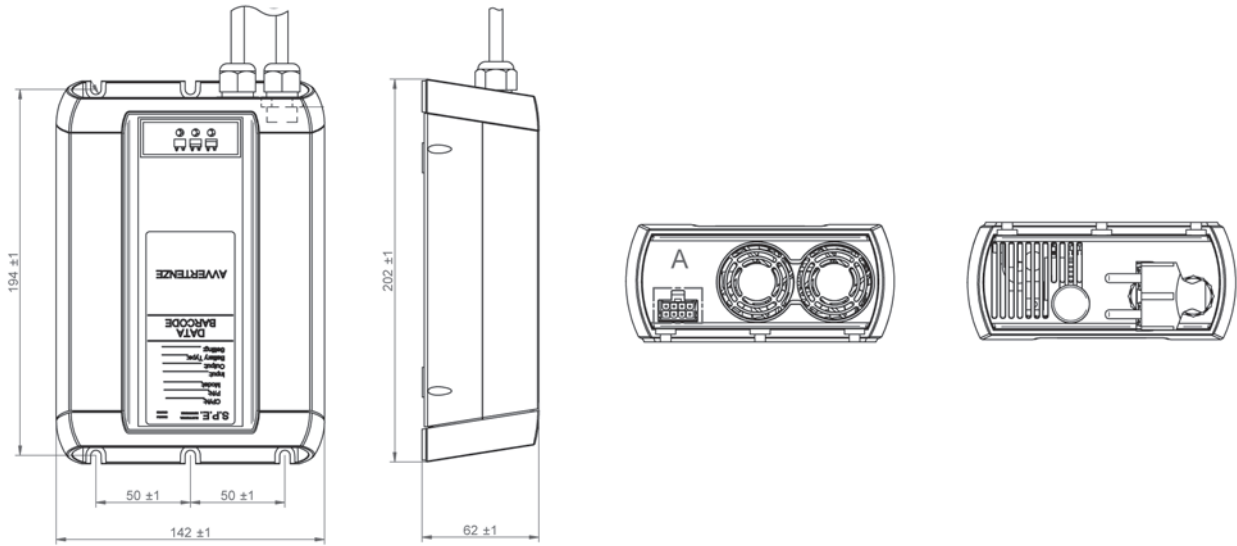

DIMENSIONS (LxWxH): 142x202x62 mm – 5.59x7.95x2.44 in
 WEIGHT: 1,80 Kg – 3.97 LBS
 PROTECTION GRADE IP30
 INPUT VOLTAGE: Universal 100÷240 Vac – 50-60 Hz

Battery Voltage	Battery Range		Charging Current	Model
	5h	20h		
12V	40÷80 Ah	60÷105 Ah	8A	12-8
	80÷130 Ah	90÷150 Ah	13A	12-13
24V	40÷80 Ah	60÷105 Ah	8A	24-8
	80÷130 Ah	90÷150 Ah	13A	24-13





CBHD1-XR-M

Main features:

Advanced and innovative resonant technology

Power from 95W up to 360W

Current from 8A to 13A

STAND-ALONE application

Configurable through membrane keyboard

APPLICATIONS



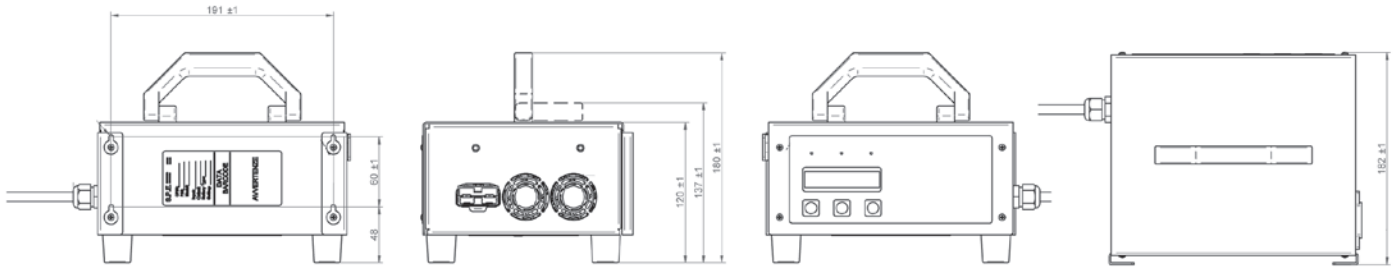

DIMENSIONS (LxWxH): 210x182x137 mm – 8.27x7.17x5.39 in

WEIGHT: 3,10 Kg – 6.84 lbs

PROTECTION GRADE IP30

INPUT VOLTAGE: Universal 100 ÷ 240 Vac – 50-60 Hz

Battery Voltage	Battery Range		Charging Current	Model
	5h	20h		
12V	40 ÷ 80 Ah	60 ÷ 105 Ah	8A	12-8
	60 ÷ 100 Ah	70 ÷ 130 Ah	10A	12-10
	80 ÷ 130 Ah	90 ÷ 150 Ah	13A	12-13
24V	40 ÷ 80 Ah	60 ÷ 105 Ah	8A	24-8
	60 ÷ 100 Ah	70 ÷ 130 Ah	10A	24-10
	80 ÷ 130 Ah	90 ÷ 150 Ah	13A	24-13



CBHD2

Main features:

Reduced weight and dimensions

Power from 180W up to 480W

Current from 15A to 20A

Available with Led on side or Led on top

APPLICATIONS



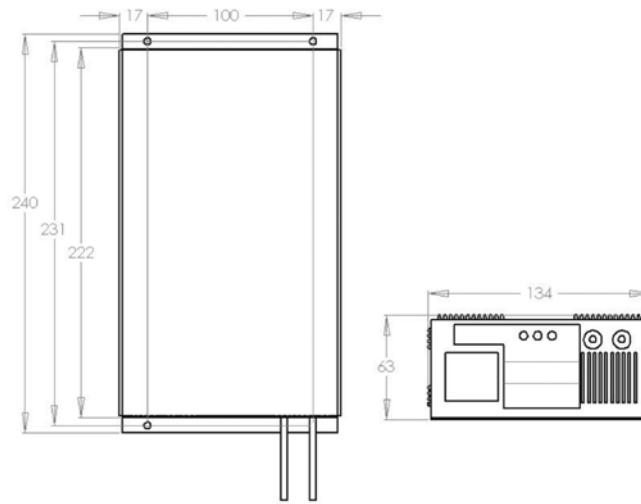

DIMENSIONS (LxWxH): 134x240x63 mm – 5.28x9.45x2.48 in
 WEIGHT: 2,20 Kg - 4.85 lbs
 PROTECTION GRADE IP30
 INPUT VOLTAGE: Universal 100 ÷ 240 Vac – 50-60 Hz

Battery Voltage	Battery Range		Charging Current	Model
	5h	20h		
12V	100 ÷ 150 Ah	130 ÷ 180 Ah	15A	12-15
	120 ÷ 195 Ah	150 ÷ 235 Ah	20A	12-20
24V	100 ÷ 150 Ah	130 ÷ 180 Ah	15A	24-15
	120 ÷ 195 Ah	150 ÷ 235 Ah	20A	24-20





CBHD3

Main features:

Reduced weight and dimensions

Power from 180W up to 600W

Current from 15A to 25A

Available in plastic and metal case
(ON-BOARD use only)

APPLICATIONS



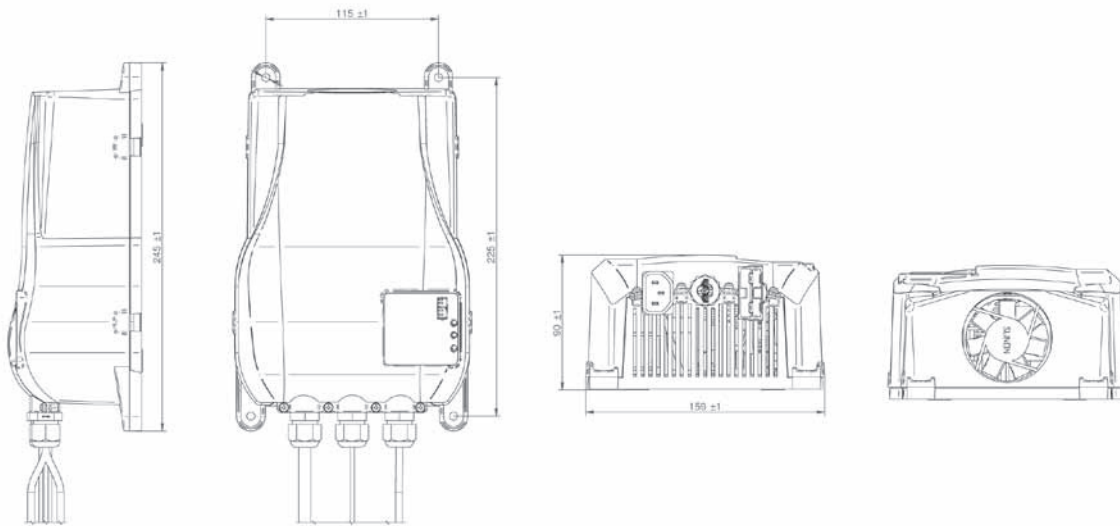

DIMENSIONS (LxWxH): 160x245x90 mm – 6.30x9.65x3.54 in
 WEIGHT: 1,90 Kg - 4.19 lbs
 PROTECTION GRADE IP30
 INPUT VOLTAGE: Universal 100 ÷ 240 Vac – 50-60 Hz

Battery Voltage	Battery Range		Charging Current	Model
	5h	20h		
12V	100 ÷ 150 Ah	130 ÷ 180 Ah	15A	12-15
	120 ÷ 195 Ah	150 ÷ 240 Ah	20A	12-20
	180 ÷ 260 Ah	220 ÷ 315 Ah	25A	12-25
24V	100 ÷ 150 Ah	130 ÷ 180 Ah	15A	24-15
	120 ÷ 195 Ah	150 ÷ 240 Ah	20A	24-20
	180 ÷ 260 Ah	220 ÷ 315 Ah	25A	24-25



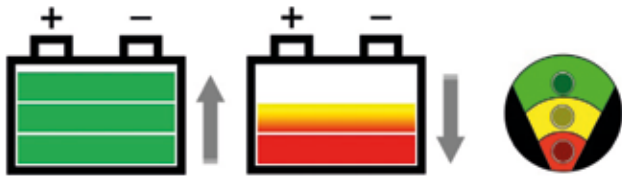

LBF CHARGE/DISCHARGE OPTION

ON-BOARD option that shows both charging status (during charging phase) and battery level (during discharging phase). It can be ordered with internal LEDs or external remote LEDs.

ELECTRONIC REMOTE MICRO-INDICATOR

External LED charging/discharging indicators which provide charge/discharge status remotely. Available in different sized and cable lengths.



LBF318EZ

18 mm round LED indicator.
Replacement P/N 714-000



LBF3QEZ

22x30 mm LED indicator.
Replacement P/N 724-000



SKLED

52x16 mm built-in LED indicator
Replacement P/N 726-000



CBNLED

83x11.50 mm built-in LED indicator.
Replacement P/N 725-100

CBHF SERIES

Single-phase battery chargers

High frequency system with advanced technology

Charging process controlled by microprocessor

Thermal protection

High brightness digital display

Voltage: 12V, 24V, 36V, 48V

Programmable for charging curve, charging current and battery voltage via dip switch

Suitable for Lead-Acid, Sealed, Gel Traction and Lithium batteries

Remote LED option

CURRENT				
12 V	4 A 8 A 10 A 12 A	14 A	15 A 20 A 25 A 30 A	35 A 40 A
24 V	4 A 8 A 10 A 12 A	14 A	15 A 20 A 25 A 30 A	35 A 40 A
36 V			15 A 20 A 25 A	30 A
48 V			15 A 20 A	22 A

■ **CBHF1-SM**

■ **CBHF1-V2**

■ **CBHF2**
CBHF2-WIFI
CBHF2-PFC
CBHF2-PFC-HK

■ **CBHF2 (XP)**
CBHF2-PCF-HK (XP)





CBHF1-SM

Main features:

Compact & lightweight

Power from 48W up to 290W

Current from 4A to 12A

APPLICATIONS



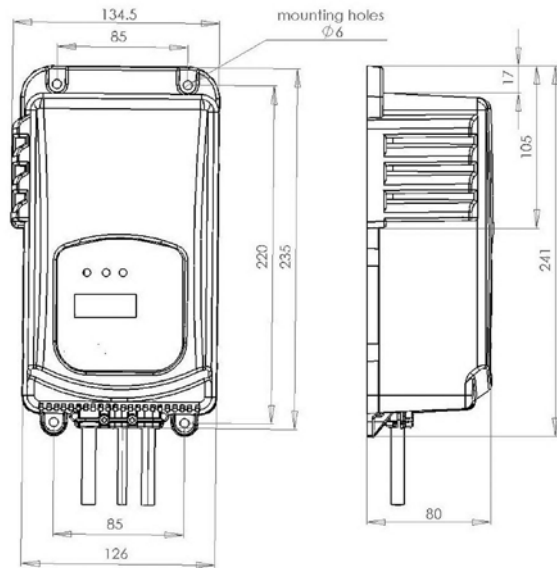

DIMENSIONS (LxWxH): 134,5x241x80 mm – 5.30x9.49x3.15 in
 WEIGHT: 1,80 Kg – 3.97 lbs
 PROTECTION GRADE IP30
 INPUT VOLTAGE: 208 ÷ 240 Vac – 50-60 Hz

Battery Voltage	Battery Range		Charging Current	Model
	5h	20h		
12V	20 ÷ 40 Ah	30 ÷ 50 Ah	4A	12-4
	40 ÷ 80 Ah	60 ÷ 105 Ah	8A	12-8
	60 ÷ 100 Ah	70 ÷ 130 Ah	10A	12-10
	90 ÷ 120 Ah	120 ÷ 160 Ah	12A	12-12
24V	20 ÷ 40 Ah	30 ÷ 50 Ah	4A	24-4
	40 ÷ 80 Ah	60 ÷ 105 Ah	8A	24-8
	60 ÷ 100 Ah	70 ÷ 130 Ah	10A	24-10
	90 ÷ 120 Ah	120 ÷ 160 Ah	12A	24-12





CBHF1-V2

Main features:

Compact & lightweight

Power from 96W up to 340W

Current from 8A to 14A

APPLICATIONS



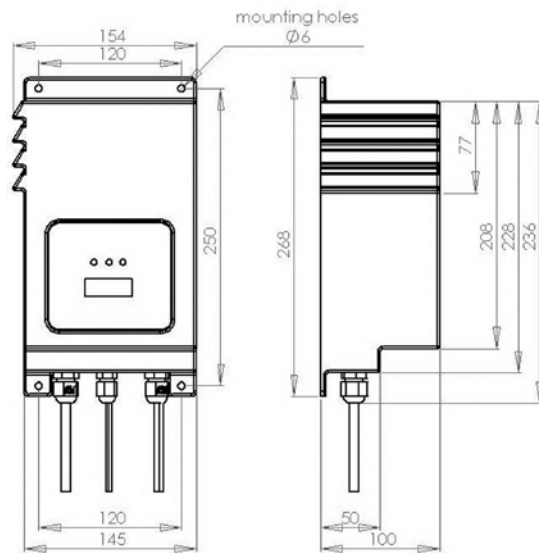

DIMENSIONS (LxWxH): 154x268x100 mm – 6.06x10.60x3.94 in

WEIGHT: 2,00 Kg - 4.41 lbs

PROTECTION GRADE IP30

INPUT VOLTAGE: 208 ÷ 240 Vac – 50-60 Hz

Battery Voltage	Battery Range		Charging Current	Model
	5h	20h		
12V	40÷80 Ah	60÷105 Ah	8A	12-8
	60÷100 Ah	70÷130 Ah	10A	12-10
	90÷120 Ah	120÷160 Ah	12A	12-12
	90÷130 Ah	120÷170 Ah	14A	12-14
24V	40÷80 Ah	60÷105 Ah	8A	24-8
	60÷100 Ah	70÷130 Ah	10A	24-10
	90÷120 Ah	120÷160 Ah	12A	24-12
	90÷130 Ah	120÷170 Ah	14A	24-14





CBHF2

Main features:

Power from 180W up to 1050W

Current from 15A to 40A

Active PFC

Charging cycles information through USB (optional)

Extra power version available (CBHF2-XP)

APPLICATIONS



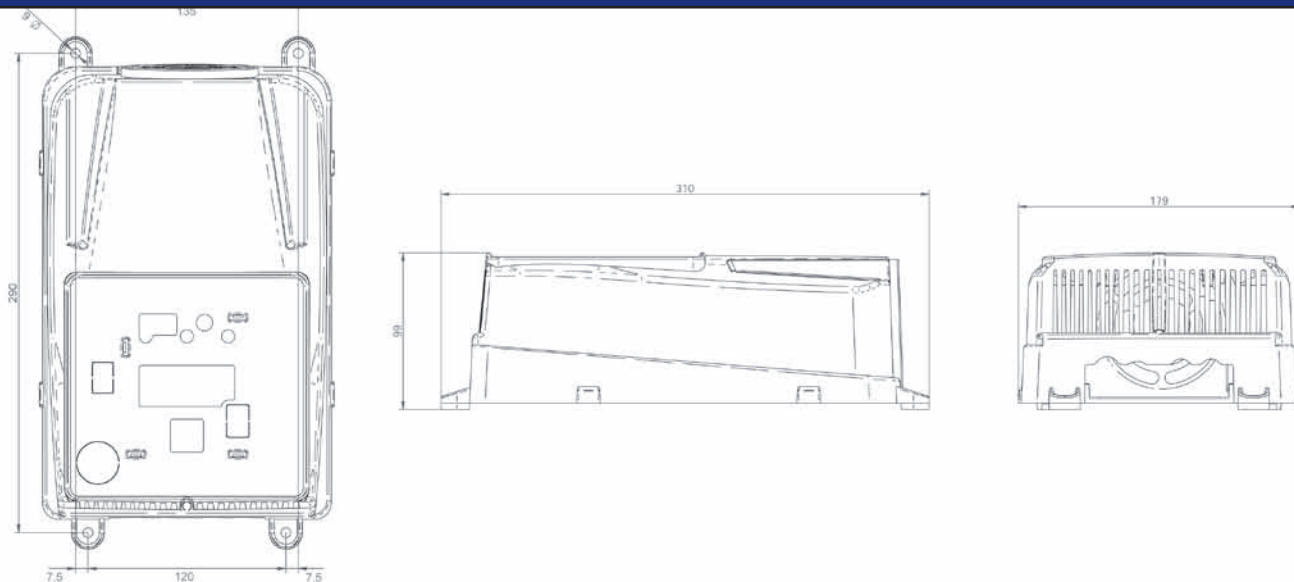

DIMENSIONS (LxWxH): 180x310x100 mm – 7.09x12.20x3.94 in

WEIGHT: 3,50 Kg - 7.72 lbs

PROTECTION GRADE IP30

INPUT VOLTAGE: Universal 100 ÷ 240 Vac – 50-60 Hz - 240 Vac only available

* CBHF2-XP 36V/48V: 208 ÷ 240 Vac – 50-60 Hz

Battery Voltage	Battery Range (5h)		Battery Range (20h) 10-12 hours charging time	Charging Current	Model
	8-9 hours charging time	10-12 hours charging time			
12V	80 ÷ 110 Ah	100 ÷ 150 Ah	130 ÷ 185 Ah	15A	12-15
	95 ÷ 120 Ah	120 ÷ 195 Ah	150 ÷ 240 Ah	20A	12-20
	120 ÷ 160 Ah	180 ÷ 260 Ah	220 ÷ 315 Ah	25A	12-25
	145 ÷ 180 Ah	200 ÷ 280 Ah	245 ÷ 350 Ah	30A	12-30
	180 ÷ 220 Ah	250 ÷ 320 Ah	305 ÷ 390 Ah	35A	12-35 (XP)
	220 ÷ 260 Ah	295 ÷ 360 Ah	360 ÷ 440 Ah	40A	12-40 (XP)
24V	80 ÷ 110 Ah	100 ÷ 150 Ah	130 ÷ 185 Ah	15A	24-15
	95 ÷ 120 Ah	120 ÷ 195 Ah	150 ÷ 240 Ah	20A	24-20
	120 ÷ 160 Ah	180 ÷ 260 Ah	220 ÷ 315 Ah	25A	24-25
	145 ÷ 180 Ah	200 ÷ 280 Ah	245 ÷ 350 Ah	30A	24-30
	180 ÷ 220 Ah	250 ÷ 320 Ah	305 ÷ 390 Ah	35A	24-35 (XP)
	220 ÷ 260 Ah	295 ÷ 360 Ah	360 ÷ 440 Ah	40A	24-40 (XP)
36V	80 ÷ 110 Ah	100 ÷ 150 Ah	130 ÷ 185 Ah	15A	36-15
	95 ÷ 120 Ah	120 ÷ 195 Ah	150 ÷ 240 Ah	20A	36-20
	120 ÷ 160 Ah	180 ÷ 260 Ah	220 ÷ 315 Ah	25A	36-25
	145 ÷ 180 Ah	200 ÷ 280 Ah	245 ÷ 350 Ah	30A	36-30 (XP)
48V	80 ÷ 110 Ah	100 ÷ 150 Ah	130 ÷ 185 Ah	15A	48-15
	95 ÷ 120 Ah	120 ÷ 195 Ah	150 ÷ 240 Ah	20A	48-20
	105 ÷ 140 Ah	150 ÷ 220 Ah	165 ÷ 265 Ah	22A	48-22 (XP)





CBHF2-WIFI

Main features:

WiFi programmable through S.P.E. 2.0 APP
(WiFi dongle required)

Charging cycles information available through
APP functions (iOS / Android)

Active PFC

APPLICATIONS



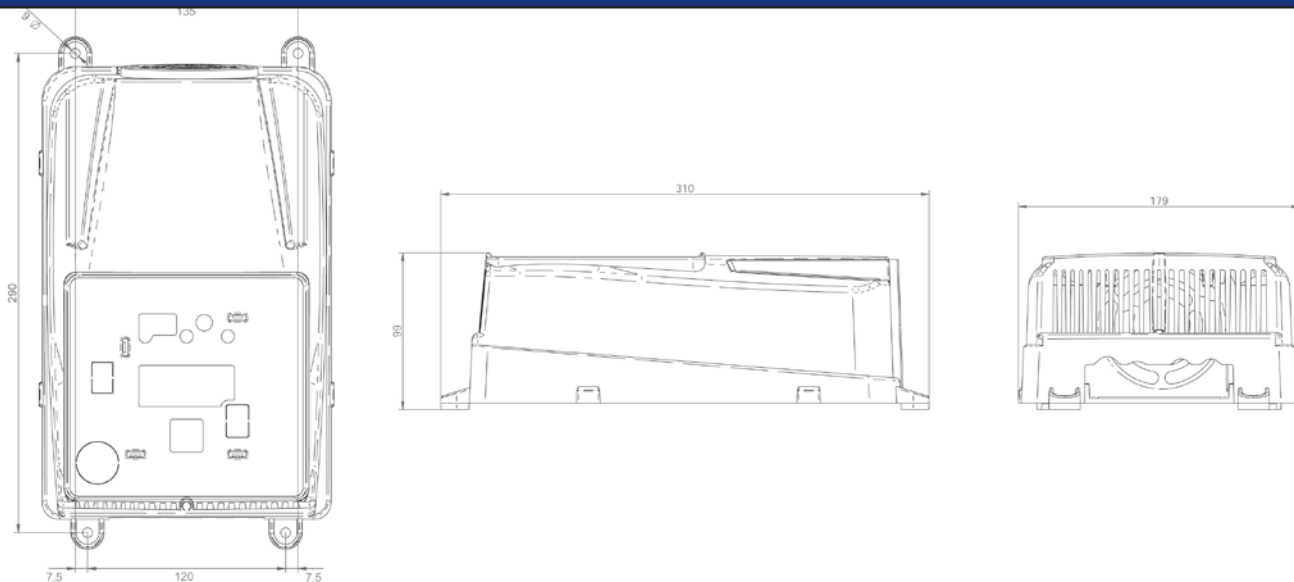

DIMENSIONS (LxWxH): 180x310x100 mm – 7.09x12.20x3.94 in

WEIGHT: 3,50 Kg - 7.72 lbs

PROTECTION GRADE IP30

INPUT VOLTAGE: Universal 100 ÷ 240 Vac – 50-60 Hz

Battery Voltage	Battery Range (5h)		Battery Range (20h) 10-12 hours charging time	Charging Current	Model
	8-9 hours charging time	10-12 hours charging time			
12V	80 ÷ 110 Ah	100 ÷ 150 Ah	130 ÷ 185 Ah	15A	12-15
	95 ÷ 120 Ah	120 ÷ 195 Ah	150 ÷ 240 Ah	20A	12-20
	120 ÷ 160 Ah	180 ÷ 260 Ah	220 ÷ 315 Ah	25A	12-25
	145 ÷ 180 Ah	200 ÷ 280 Ah	245 ÷ 350 Ah	30A	12-30
24V	80 ÷ 110 Ah	100 ÷ 150 Ah	130 ÷ 185 Ah	15A	24-15
	95 ÷ 120 Ah	120 ÷ 195 Ah	150 ÷ 240 Ah	20A	24-20
	120 ÷ 160 Ah	180 ÷ 260 Ah	220 ÷ 315 Ah	25A	24-25
	145 ÷ 180 Ah	200 ÷ 280 Ah	245 ÷ 350 Ah	30A	24-30
36V	80 ÷ 110 Ah	100 ÷ 150 Ah	130 ÷ 185 Ah	15A	36-15
	95 ÷ 120 Ah	120 ÷ 195 Ah	150 ÷ 240 Ah	20A	36-20
	120 ÷ 160 Ah	180 ÷ 260 Ah	220 ÷ 315 Ah	25A	36-25
48V	80 ÷ 110 Ah	100 ÷ 150 Ah	130 ÷ 185 Ah	15A	48-15
	95 ÷ 120 Ah	120 ÷ 195 Ah	150 ÷ 240 Ah	20A	48-20



Available on
App Store
Google Play





CBHF2-PFC

Main features:

Active PFC

Metal case with handle

Portable design

STAND-ALONE application

APPLICATIONS



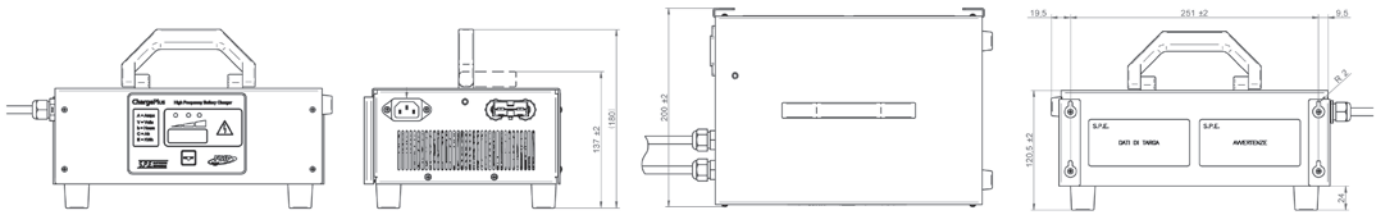

DIMENSIONS (LxWxH): 280x200x137 mm – 11.02x7.87x5.39 in
 WEIGHT: 5 Kg - 11.02 lbs
 PROTECTION GRADE IP30
 INPUT VOLTAGE: Universal 100 ÷ 240 Vac – 50-60 Hz

Battery Voltage	Battery Range (5h)		Battery Range (20h) 10-12 hours charging time	Charging Current	Model
	8-9 hours charging time	10-12 hours charging time			
12V	80 ÷ 110 Ah	100 ÷ 150 Ah	130 ÷ 185 Ah	15A	12-15
	95 ÷ 120 Ah	120 ÷ 195 Ah	150 ÷ 240 Ah	20A	12-20
	120 ÷ 160 Ah	180 ÷ 260 Ah	220 ÷ 315 Ah	25A	12-25
	145 ÷ 180 Ah	200 ÷ 280 Ah	245 ÷ 350 Ah	30A	12-30
24V	80 ÷ 110 Ah	100 ÷ 150 Ah	130 ÷ 185 Ah	15A	24-15
	95 ÷ 120 Ah	120 ÷ 195 Ah	150 ÷ 240 Ah	20A	24-20
	120 ÷ 160 Ah	180 ÷ 260 Ah	220 ÷ 315 Ah	25A	24-25
	145 ÷ 180 Ah	200 ÷ 280 Ah	245 ÷ 350 Ah	30A	24-30
36V	80 ÷ 110 Ah	100 ÷ 150 Ah	130 ÷ 185 Ah	15A	36-15
	95 ÷ 120 Ah	120 ÷ 195 Ah	150 ÷ 240 Ah	20A	36-20
	120 ÷ 160 Ah	180 ÷ 260 Ah	220 ÷ 315 Ah	25A	36-25
48V	80 ÷ 110 Ah	100 ÷ 150 Ah	130 ÷ 185 Ah	15A	48-15
	95 ÷ 120 Ah	120 ÷ 195 Ah	150 ÷ 240 Ah	20A	48-20





CBHF2-PFC-HK

Main features:

STOP button on front panel

Hard metal case

ON-BOARD application

Extra Power version available (XP model)

APPLICATIONS



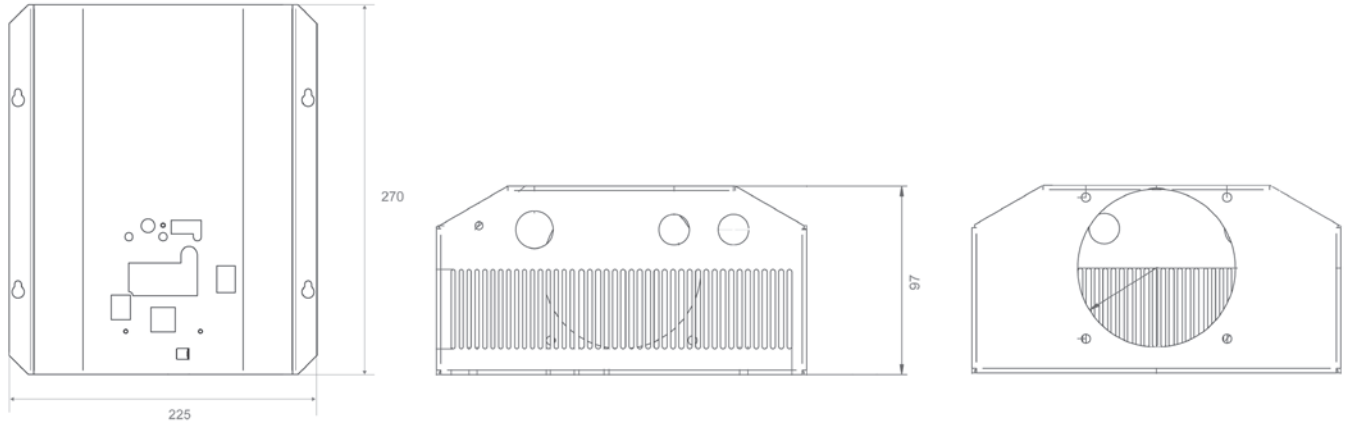

DIMENSIONS (LxWxH): 270x225x97 mm – 10.63x8.86x3.82 in

WEIGHT: 4 Kg - 8.82 lbs

PROTECTION GRADE IP30

INPUT VOLTAGE: 100 ÷ 240 Vac – 50-60 Hz

* XP model 36V/48V: 208 ÷ 240 Vac – 50-60 Hz

Battery Voltage	Battery Range (5h)		Battery Range (20h) 10-12 hours charging time	Charging Current	Model
	8-9 hours charging time	10-12 hours charging time			
12V	80 ÷ 110 Ah	100 ÷ 150 Ah	130 ÷ 185 Ah	15A	12-15
	95 ÷ 120 Ah	120 ÷ 195 Ah	150 ÷ 240 Ah	20A	12-20
	120 ÷ 160 Ah	180 ÷ 260 Ah	220 ÷ 315 Ah	25A	12-25
	145 ÷ 180 Ah	200 ÷ 280 Ah	245 ÷ 350 Ah	30A	12-30
	180 ÷ 220 Ah	250 ÷ 320 Ah	305 ÷ 390 Ah	35A	12-35 (XP)
	220 ÷ 260 Ah	295 ÷ 360 Ah	360 ÷ 440 Ah	40A	12-40 (XP)
24V	80 ÷ 110 Ah	100 ÷ 150 Ah	130 ÷ 185 Ah	15A	24-15
	95 ÷ 120 Ah	120 ÷ 195 Ah	150 ÷ 240 Ah	20A	24-20
	120 ÷ 160 Ah	180 ÷ 260 Ah	220 ÷ 315 Ah	25A	24-25
	145 ÷ 180 Ah	200 ÷ 280 Ah	245 ÷ 350 Ah	30A	24-30
	180 ÷ 220 Ah	250 ÷ 320 Ah	305 ÷ 390 Ah	35A	24-35 (XP)
	220 ÷ 260 Ah	295 ÷ 360 Ah	360 ÷ 440 Ah	40A	24-40 (XP)
36V	80 ÷ 110 Ah	100 ÷ 150 Ah	130 ÷ 185 Ah	15A	36-15
	95 ÷ 120 Ah	120 ÷ 195 Ah	150 ÷ 240 Ah	20A	36-20
	120 ÷ 160 Ah	180 ÷ 260 Ah	220 ÷ 315 Ah	25A	36-25
	145 ÷ 180 Ah	200 ÷ 280 Ah	245 ÷ 350 Ah	30A	36-30 (XP)
48V	80 ÷ 110 Ah	100 ÷ 150 Ah	130 ÷ 185 Ah	15A	48-15
	95 ÷ 120 Ah	120 ÷ 195 Ah	150 ÷ 240 Ah	20A	48-20
	105 ÷ 140 Ah	150 ÷ 220 Ah	165 ÷ 265 Ah	22A	48-22 (XP)



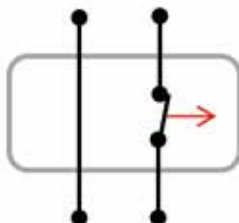
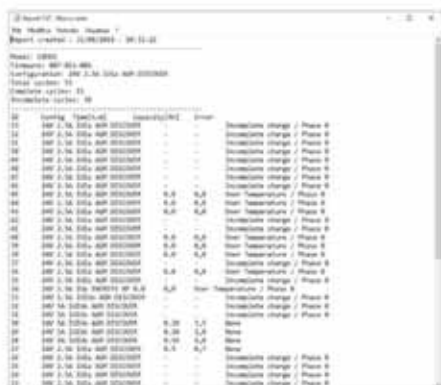

DATA LOGGING OPTION

Capability to log up to 100 charging cycles in order to analyze battery performances and usage by the customer. All data are available through SPE Reader software on dedicated chargers (included).

TTL JACK/USB serial cable is required for download (P/N 589-001).

SPE READER SOFTWARE

Through SPE Reader software, connecting PC and charger using TTL-232R-5V-AJ JACK/USB cable, allows to download on a simple .txt file charging data including Ah, time of charge, incomplete cycles and charger configuration. The software is STAND-ALONE and does not require any installation. Works with any Windows© installation.

TTL JACK/USB SERIAL CABLE

USB to JACK 3.5mm data cable which connects PC to charger. To be ordered separately (P/N 589-001).

CAN BUS OPTION

CAN BUS option to remotely read/write data from/to the charger. This includes configuration change and parameters' reading (voltage, current, charging profile and charging phase). CAN Open sub-dictionary available.

Option available on selected models.

INHIBIT RELAY (IMMOBILIZER)

ON-BOARD charger option to disable usage of the machine during the charging phase (NC contact).

NA contact available on request.

ELECTRONIC REMOTE MICRO-INDICATOR

External LED charging/discharging indicators which provide charge/discharge status remotely. Available in different sized and cable lengths.



LBF318EZ

18 mm round LED indicator.
Replacement P/N 714-000



LBF3QEZ

22x30 mm LED indicator.
Replacement P/N 724-000



SKLED

52x16 mm built-in LED indicator
Replacement P/N 726-000



CBNLED

83x11.50 mm built-in LED indicator.
Replacement P/N 725-100

SEALED SERIES

Single-phase battery chargers

High frequency system with advanced technology

IP rated (International Protection)

Thermal protection against over-heating

Charging process fully controlled by microprocessor

Suitable for Lead-Acid, Sealed, Gel Traction and Lithium batteries

Active PFC

CURRENT				
12 V	10 A 13 A	25 A		
24 V	10 A	25 A	30 A	50 A
36 V		15 A 20 A	20 A	35 A
48 V		12 A 15 A 17 A	15 A	25 A

HF1-IP

HF2-UI-PFC

TORO1000

TORO1200





HF1-IP

Main features:

Integrated battery discharge indicator

Fan less design

IP 55 (optional IP65)

Power from 155W up to 240W

Current from 10A to 13A

APPLICATIONS



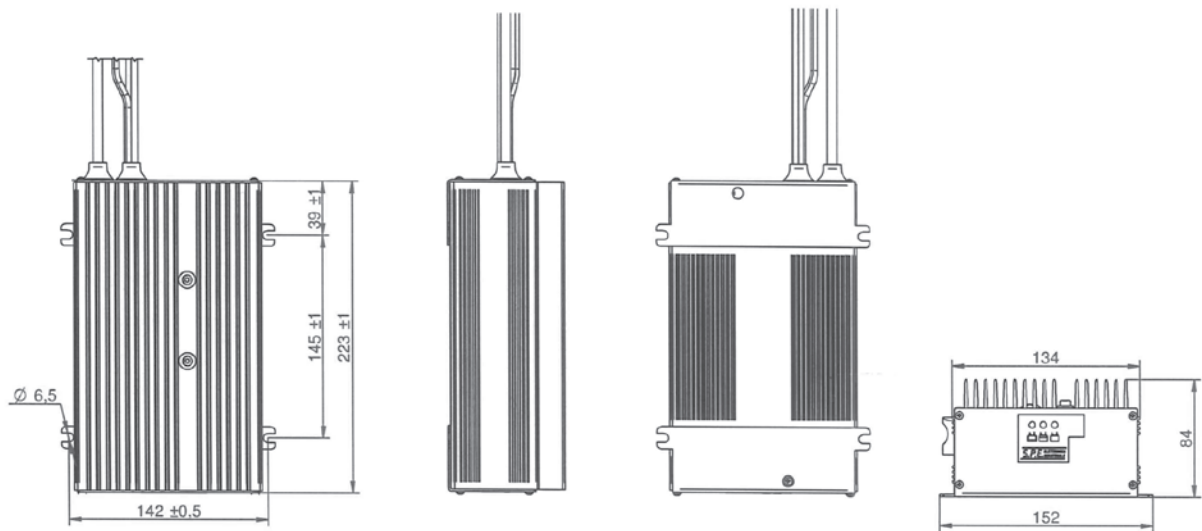

DIMENSIONS (LxWxH): 152x225x84 mm – 5.98x8.86x3.31 in
 WEIGHT: 3,00 Kg - 6.61 lbs
 PROTECTION GRADE IP55
 INPUT VOLTAGE: Universal 100 ÷ 240 Vac – 50-60 Hz

Battery Voltage	Battery Range		Charging Current	Model
	5h	20h		
12V	60 ÷ 100 Ah	70 ÷ 130 Ah	10A	12-10
	80 ÷ 130 Ah	90 ÷ 150 Ah	13A	12-13
24V	60 ÷ 100 Ah	70 ÷ 130 Ah	10A	24-10



HF2-UI-PFC

Main features:

Fan less design

IP66

External charging indicator

Power from 360W up to 720W

Current from 15A to 25A

Available in 12V, 24V, 36V or 48V

APPLICATIONS





TORO1000

Main features:

Fan less design

IP65

Integrated or external charging indicator

Power from 360W up to 720W

Current from 15A to 30A

Available in 12V, 24V, 36V or 48V

APPLICATIONS



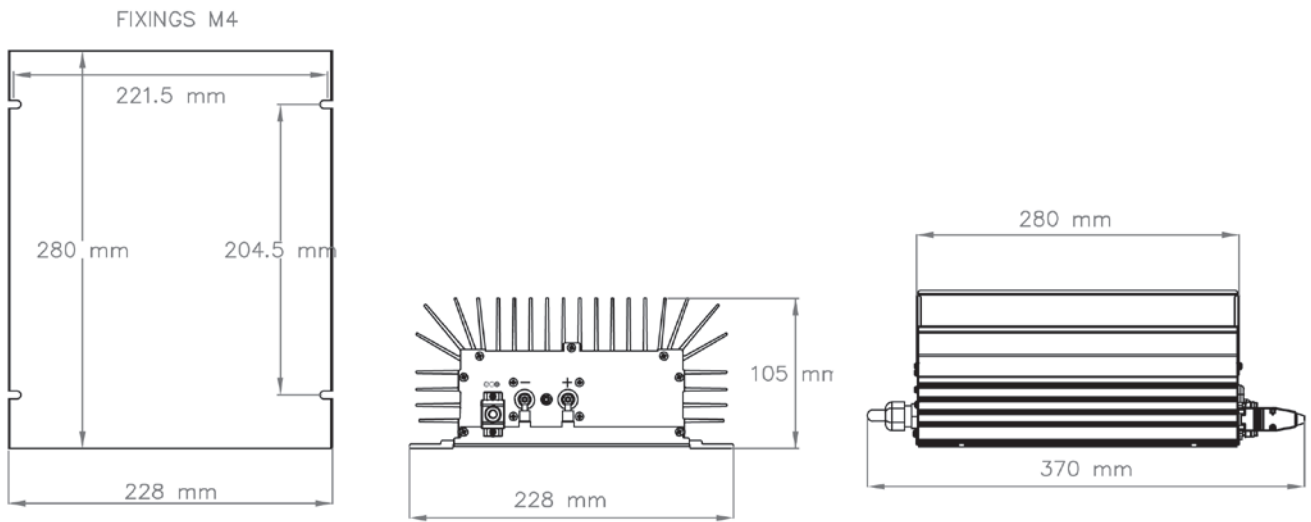

DIMENSIONS (LxWxH): 280x105x228mm – 11.02x4.13x8.98 in

WEIGHT: 4,80 Kg - 10,58 lbs

PROTECTION GRADE IP65

INPUT VOLTAGE: Universal 100 ÷ 240 Vac – 50-60 Hz

Battery Voltage	Battery Range		Charging Current	Model
	5h	20h		
24	200 ÷ 280 Ah	245 ÷ 350 Ah	30A	24-30
36	120 ÷ 195 Ah	150 ÷ 240 Ah	20A	36-20
48	100 ÷ 150 Ah	130 ÷ 185 Ah	15A	48-15



TORO1200

Main features:

IP65 external ventilator

Integrated or external charging indicator

Power from 720W up to 1200W

Current from 30A to 50A

Available in 12V, 24V, 36V or 48V

APPLICATIONS



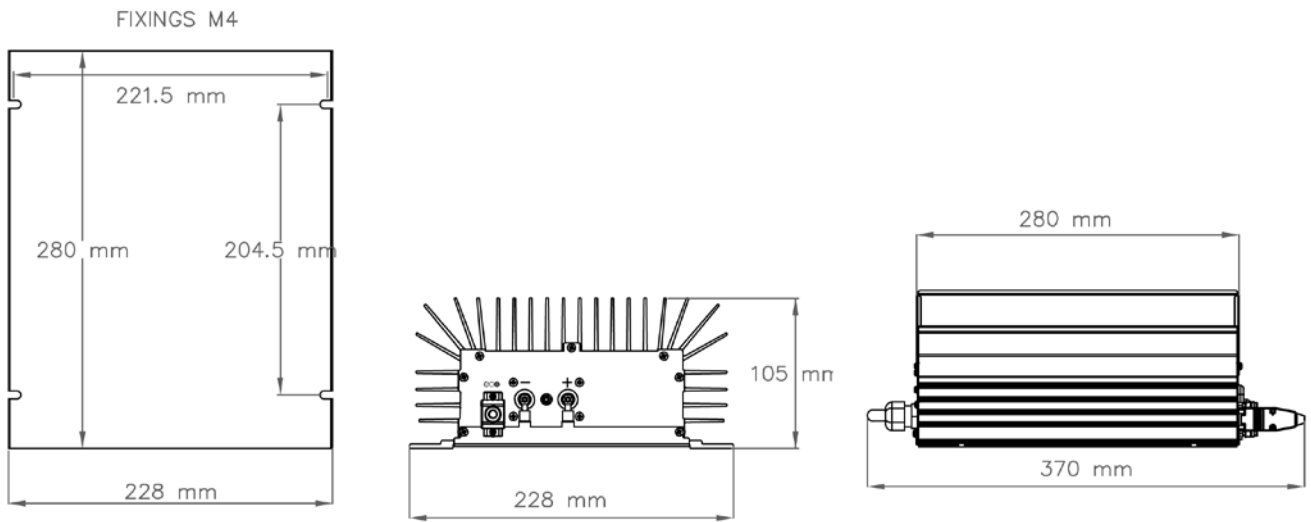

DIMENSIONS (LxWxH): 280x105x228mm – 11.02x4.13x8.98 in

WEIGHT: 5,50 Kg - 12.13 lbs

PROTECTION GRADE IP65

INPUT VOLTAGE: Universal 100 ÷ 240 Vac – 50-60 Hz

Battery Voltage	Battery Range		Charging Current	Model
	5h	20h		
24	350 ÷ 420 Ah	420 ÷ 540 Ah	50A	24-50
36	255 ÷ 320 Ah	310 ÷ 390 Ah	35A	36-30
48	175 ÷ 210 Ah	210 ÷ 270 Ah	25A	48-25

CBSW SERIES

Single-phase battery chargers

High frequency advanced Mosfet technology

Input insulation transformer

High brightness digital display

Efficiency over 85%

Programmable for charging curve, charging current and battery voltage via dip switch

STAND-ALONE application

Suitable for Lead-Acid, Sealed and Gel Traction

CURRENT			
12 V	4 A 8 A 10 A 12 A	15 A 20 A 25 A 30 A	40 A 50 A 60 A
24 V	4 A 8 A 10 A 12 A	15 A 20 A 25 A 30 A	40 A 50 A 60 A
36 V		20 A 25 A	30 A 40 A 50 A 60 A
48 V		20 A	25 A

CBSW1-S

CBSW2-S

CBSW4-S





CBSW1-S

Main features:

Power from 48W up to 290W

Voltage 12V and 24V selectable

Current from 4A to 12A

Fan less design

APPLICATIONS



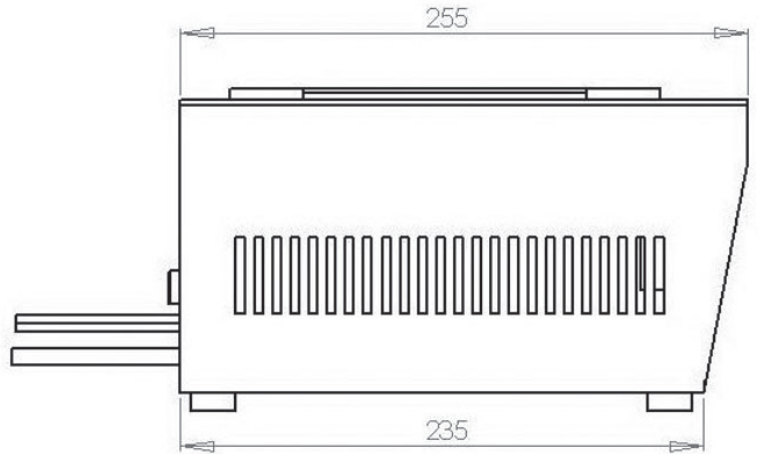
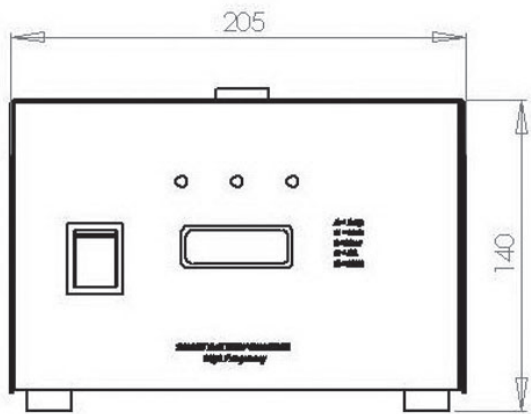

DIMENSIONS (LxWxH): 205x255x140 mm – 8.07x10.04x5.51 in

WEIGHT: 5,90-9,60 Kg – 13.01-21.16 lbs

PROTECTION GRADE IP20

INPUT VOLTAGE: 115/240 Vac – 50-60 Hz

Battery Voltage	Battery Range		Charging Current	Model
	5h	20h		
12V	20 ÷ 40 Ah	30 ÷ 50 Ah	4A	12-4
	40 ÷ 80 Ah	60 ÷ 105 Ah	8A	12-8
	60 ÷ 100 Ah	70 ÷ 130 Ah	10A	12-10
	90 ÷ 120 Ah	120 ÷ 160 Ah	12A	12-12
24V	20 ÷ 40 Ah	30 ÷ 50 Ah	4A	24-4
	40 ÷ 80 Ah	60 ÷ 105 Ah	8A	24-8
	60 ÷ 100 Ah	70 ÷ 130 Ah	10A	24-10
	90 ÷ 120 Ah	120 ÷ 160 Ah	12A	24-12



CBSW2-S

Main features:

Power from 180W up to 1050W

Voltage 12V, 24V, 36V and 48V selectable

Current from 15A to 40A

APPLICATIONS



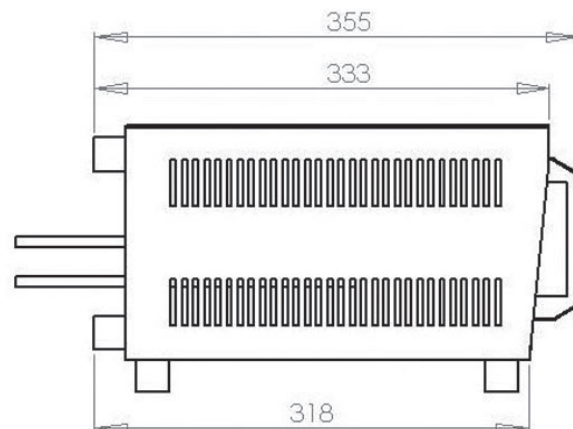
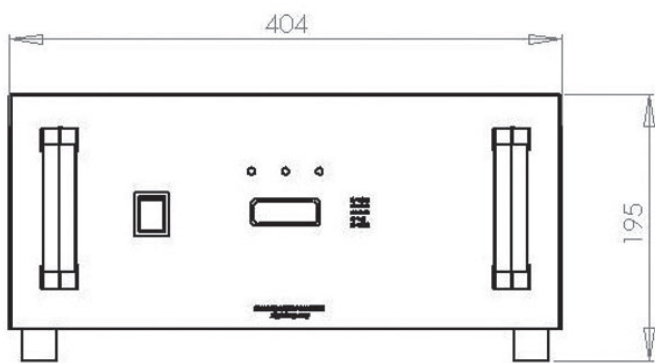

DIMENSIONS (LxWxH): 404x355x195 mm – 15.91x13.98x7.68 in

WEIGHT: 15,80-22,80 Kg – 34.83-50.27 lbs

PROTECTION GRADE IP20

INPUT VOLTAGE: 115/240 Vac – 50-60 Hz

Battery Voltage	Battery Range		Charging Current	Model
	5h	20h		
12V	100 ÷ 150 Ah	130 ÷ 180 Ah	15A	12-15
	120 ÷ 195 Ah	150 ÷ 235 Ah	20A	12-20
	180 ÷ 240 Ah	240 ÷ 320 Ah	25A	12-25
	260 ÷ 320 Ah	340 ÷ 425 Ah	30A	12-30
24V	100 ÷ 150 Ah	130 ÷ 180 Ah	15A	24-15
	120 ÷ 195 Ah	150 ÷ 235 Ah	20A	24-20
	180 ÷ 240 Ah	240 ÷ 320 Ah	25A	24-25
	260 ÷ 320 Ah	340 ÷ 425 Ah	30A	24-30
36V	120 ÷ 180 Ah	155 ÷ 210 Ah	20A	36-20
	180 ÷ 240 Ah	240 ÷ 320 Ah	25A	36-25
48V	120 ÷ 195 Ah	150 ÷ 235 Ah	20A	48-20



CBSW4-S

Main features:

Voltage, current and charging profile configurable with smart cards (provided separately)

Power from 480W up to 2160W

Voltage 12V, 24V, 36V and 48V

Current from 40A to 60A

APPLICATIONS



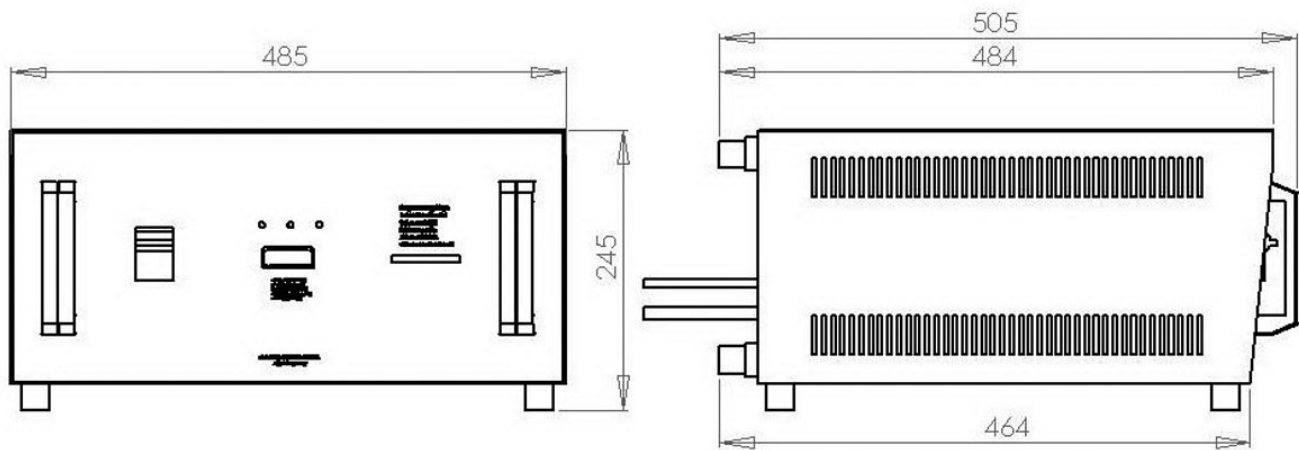

DIMENSIONS (LxWxH): 485x505x245 mm – 19.09x19.88x9.65 in

WEIGHT: 36,40-49 Kg – 80.25-108 lbs

PROTECTION GRADE IP20

INPUT VOLTAGE: 240 Vac – 50-60 Hz

Battery Voltage	Battery Range		Charging Current	Model
	5h	20h		
12V	300 ÷ 360 Ah	370 ÷ 450 Ah	40A	12-40
	360 ÷ 440 Ah	420 ÷ 540 Ah	50A	12-50
	450 ÷ 550 Ah	560 ÷ 650 Ah	60A	12-60
24V	300 ÷ 360 Ah	370 ÷ 450 Ah	40A	24-40
	360 ÷ 440 Ah	420 ÷ 540 Ah	50A	24-50
	450 ÷ 550 Ah	560 ÷ 650 Ah	60A	24-60
36V	260 ÷ 320 Ah	340 ÷ 425 Ah	30A	36-30
	300 ÷ 360 Ah	370 ÷ 450 Ah	40A	36-40
	360 ÷ 440 Ah	420 ÷ 540 Ah	50A	36-50
	450 ÷ 550 Ah	505 ÷ 675 Ah	60A	36-60
48V	285 ÷ 360 Ah	335 ÷ 450 Ah	40A	48-40

CBN SERIES

Single-phase battery chargers

Thyristor control and excellent reliability
(Silicon Controlled Rectifier)

Wa & IU charging profiles available

Constant voltage during U charging phases

Suitable for Lead Acid batteries

Analog current meter

CURRENT			
12 V	4 A 8 A 10 A 12 A	15 A 20 A 25 A 30 A	40 A 50 A 60 A
24 V	4 A 8 A 10 A 12 A	15 A 20 A 25 A 30 A	40 A 50 A 60 A
36 V		20 A	25 A 30 A 40 A

■ CBN1

■ CBN2

■ CBN4





CBN1

Main features:

Power from 48W up to 290W

Voltage 12V and 24V

Current from 4A to 12A

Handle on top for easy carry

APPLICATIONS



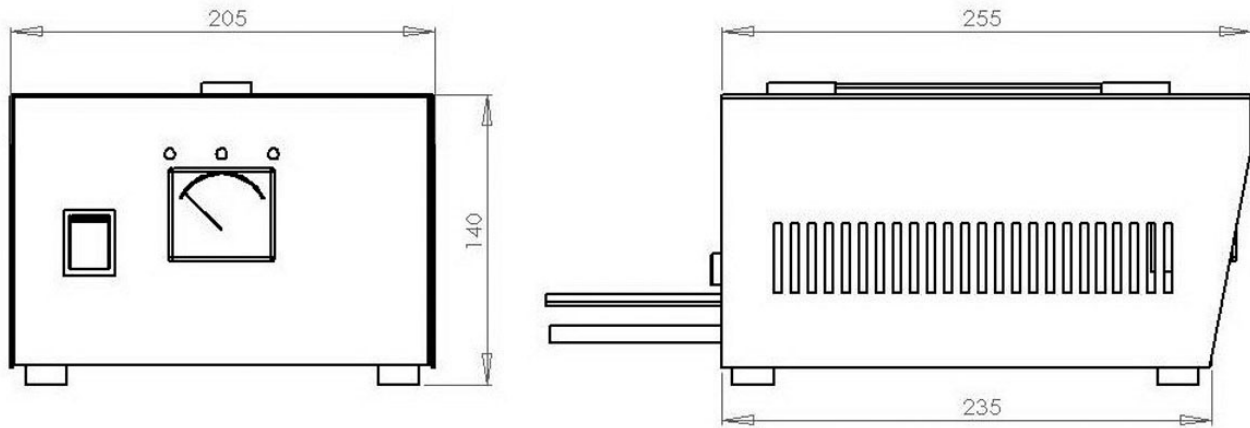

DIMENSIONS (LxWxH): 205x255x140 mm – 8.07x10.04x5.51 in

WEIGHT: 5-9 Kg – 11.02-19.84 lbs

PROTECTION GRADE IP20

INPUT VOLTAGE: 240 Vac – 50-60 Hz

Battery Voltage	Battery Range		Charging Current	Model
	5h	20h		
12V	20 ÷ 40 Ah	30 ÷ 50 Ah	4A	12-4
	40 ÷ 60 Ah	50 ÷ 70 Ah	8A	12-8
	60 ÷ 90 Ah	70 ÷ 120 Ah	10A	12-10
	80 ÷ 105 Ah	95 ÷ 140 Ah	12A	12-12
24V	20 ÷ 40 Ah	30 ÷ 50 Ah	4A	24-4
	40 ÷ 60 Ah	50 ÷ 70 Ah	8A	24-8
	60 ÷ 90 Ah	70 ÷ 120 Ah	10A	24-10
	80 ÷ 105 Ah	95 ÷ 140 Ah	12A	24-12



CBN2

Main features:

Power from 180W up to 720W

Voltage 12V, 24V and 36V

Current from 15A to 30A

Front handles for easy carry

APPLICATIONS



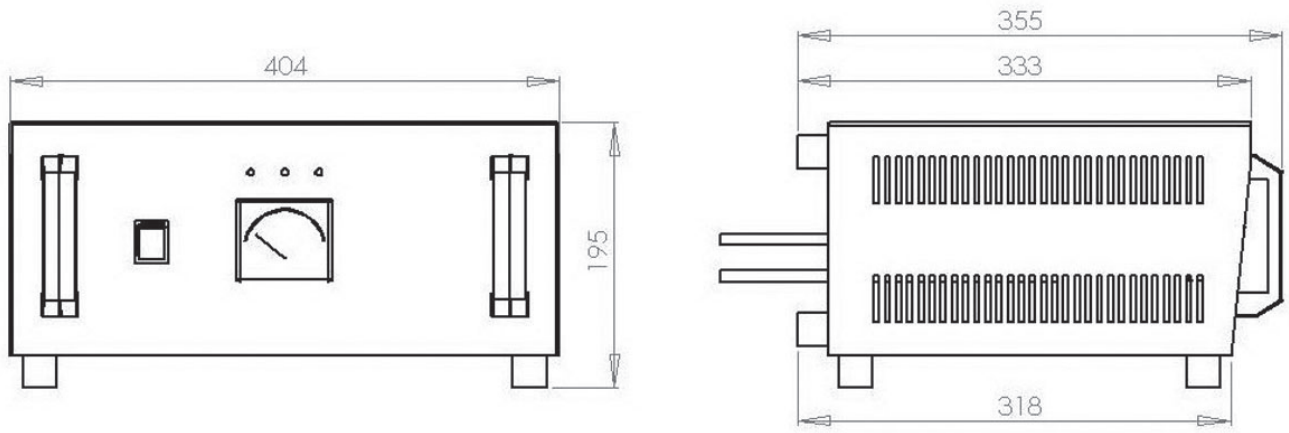

DIMENSIONS (LxWxH): 404x355x195 mm – 15.91x13.98x7.68 in
 WEIGHT: 14,60-22,80 Kg –32.19-50.27 lbs
 PROTECTION GRADE IP20
 INPUT VOLTAGE: 240 Vac – 50-60 Hz

Battery Voltage	Battery Range		Charging Current	Model
	5h	20h		
12V	100÷120 Ah	105÷160 Ah	15A	12-15
	120÷180 Ah	155÷210 Ah	20A	12-20
	160÷200 Ah	200÷290 Ah	25A	12-25
	200÷260 Ah	250÷330 Ah	30A	12-30
24V	100÷120 Ah	105÷160 Ah	15A	24-15
	120÷180 Ah	155÷210 Ah	20A	24-20
	160÷200 Ah	200÷290 Ah	25A	24-25
	200÷260 Ah	250÷330 Ah	30A	24-30
36V	120÷180 Ah	155÷210 Ah	20A	36-20



CBN4

Main features:

Power from 480W up to 1800W

Voltage 12V, 24V and 36V

Current from 40A to 60A

Front handles for easy carry

APPLICATIONS



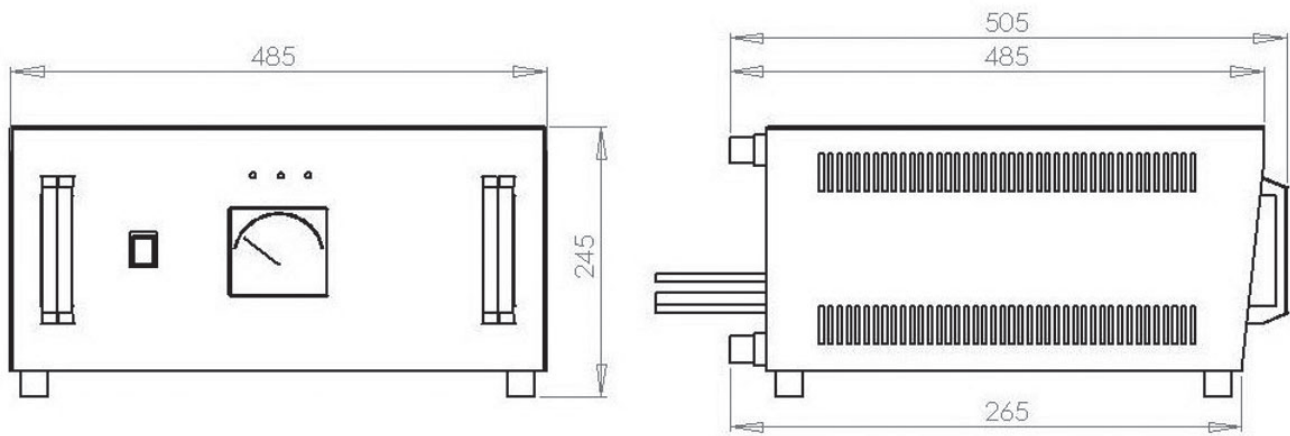

DIMENSIONS (LxWxH): 485x505x245 mm – 19.09x19.88x10 in

WEIGHT: 29,50-44,20 Kg – 65.04-97.44 lbs

PROTECTION GRADE IP20

INPUT VOLTAGE: 240 Vac – 50-60 Hz

Battery Voltage	Battery Range		Charging Current	Model
	5h	20h		
12V	300 ÷ 360 Ah	370 ÷ 450 Ah	40A	12-40
	350 ÷ 420 Ah	420 ÷ 540 Ah	50A	12-50
	450 ÷ 520 Ah	560 ÷ 650 Ah	60A	12-60
24V	300 ÷ 360 Ah	370 ÷ 450 Ah	40A	24-40
	350 ÷ 420 Ah	420 ÷ 540 Ah	50A	24-50
	450 ÷ 520 Ah	560 ÷ 650 Ah	60A	24-60
36V	160 ÷ 200 Ah	200 ÷ 290 Ah	25A	36-25
	200 ÷ 260 Ah	250 ÷ 330 Ah	30A	36-30
	300 ÷ 360 Ah	370 ÷ 450 Ah	40A	36-40

GREEN SERIES SINGLE-PHASE BATTERY CHARGERS

Single-phase battery chargers

High frequency switching technology

Active PFC (Power Factor Corrector)

High efficiency technology and new technical design for optimal battery thermal performances

Programmable via front panel or USB type A/B port

Suitable for Lead-Acid, Sealed and Gel Traction batteries

CAN/CAN-open BUS communication for Lithium batteries

High efficiency over 90%

Various configurations available

Multi current configuration

Customizable charging curves through software

Integrated data logger

HFView software included

CURRENT		
24 V	50 A 60 A 70 A	80 A 90 A 100 A 120 A
36 V	40 A 45 A	50 A 60 A 70 A 80 A 90 A
48 V	30 A 40 A	50 A 60 A 75 A
72 V	25 A	30 A 40 A 50 A
80 V	20 A	30 A 40 A
96 V	17 A	25 A 30 A 35 A

 **Green2**

 **Green4**





GREEN2

Main features:

Power up to 2.5 kW, from 24V up to 96V,
from 17A up to 70A

Programmable via USB type A/B port or via display

Graphical display

APPLICATIONS



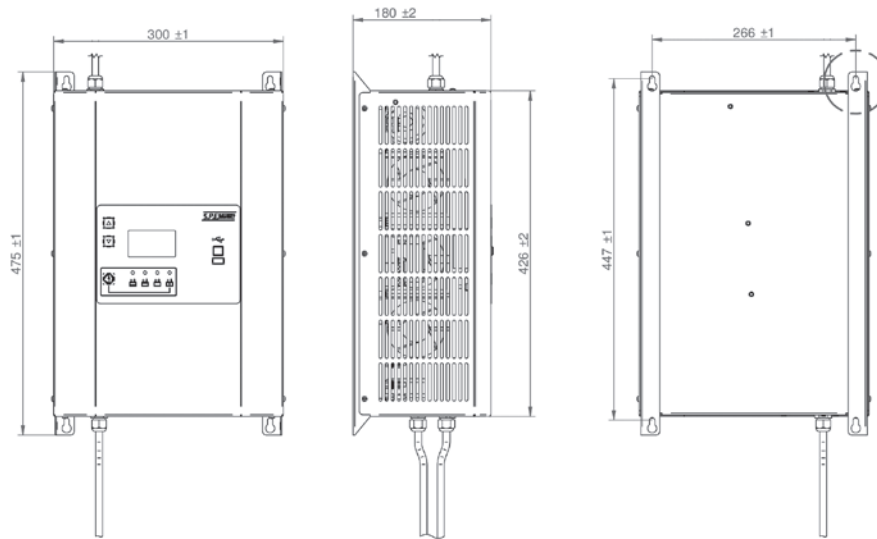

DIMENSIONS (LxWxH): 300x475x180 mm – 11.81x18.70x7.09 in.

WEIGHT: 11 Kg – 24.25 lbs

PROTECTION GRADE IP20

INPUT VOLTAGE: 120/200-240 Vac

Battery Voltage	IUIa Wet 8h Range (C5)	IUIa Wet 12h Range (C5)	IUIa Gel PzV 10-14h Range (C5)	Charging Current	Model
24V	280 ÷ 340 Ah	450 ÷ 550 Ah	350 ÷ 420 Ah	50A	24-50
	340 ÷ 410 Ah	540 ÷ 660 Ah	420 ÷ 510 Ah	60A	24-60
	390 ÷ 480 Ah	630 ÷ 770 Ah	480 ÷ 590 Ah	70A	24-70
36V	230 ÷ 280 Ah	360 ÷ 440 Ah	275 ÷ 340 Ah	40A	36-40
	250 ÷ 310 Ah	410 ÷ 500 Ah	310 ÷ 380 Ah	45A	36-45
48V	170 ÷ 210 Ah	270 ÷ 330 Ah	210 ÷ 255 Ah	30A	48-30
	230 ÷ 280 Ah	360 ÷ 440 Ah	275 ÷ 340 Ah	40A	48-40
72V	140 ÷ 170 Ah	230 ÷ 280 Ah	175 ÷ 210 Ah	25A	72-25
80V	110 ÷ 140 Ah	180 ÷ 220 Ah	140 ÷ 170 Ah	20A	80-20
96V	100 ÷ 120 Ah	155 ÷ 190 Ah	115 ÷ 145 Ah	17A	96-17



GREEN4

Main features:

Power up to 4.5 kW, from 24V up to 96V,
from 25A up to 120A

Programmable via USB type A/B port or via display

Graphical display

APPLICATIONS



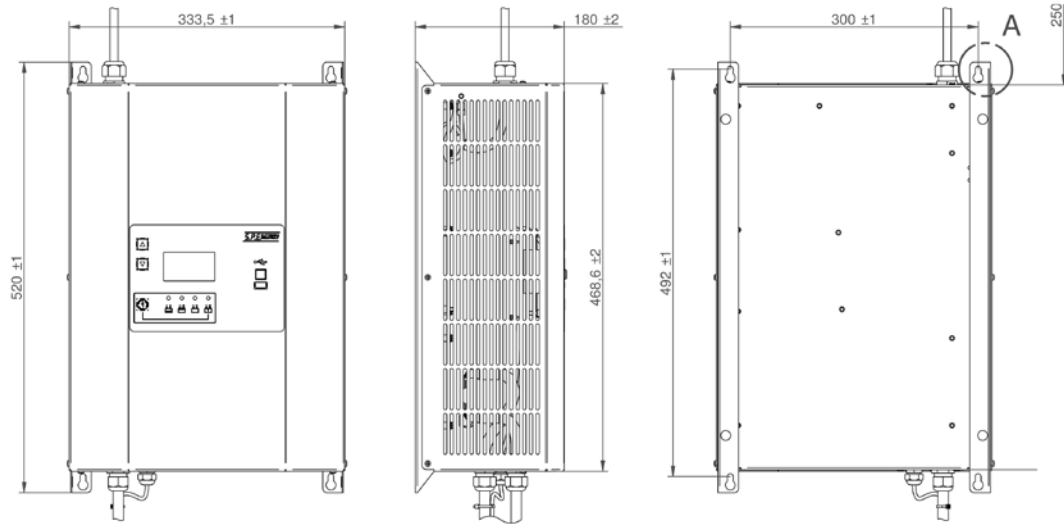

DIMENSIONS (LxWxH): 333.50x520x180 mm – 13.13x20.47x7.09 in.

WEIGHT: 13 Kg – 28.66 lbs

PROTECTION GRADE IP20

INPUT VOLTAGE: 200-240Vac

Battery Voltage	IUIa Wet 8h Range (C5)	IUIa Wet 12h Range (C5)	IUIa Gel PzV 10-14h Range (C5)	Charging Current	Model
24V	450 ÷ 550 Ah	720 ÷ 880 Ah	550 ÷ 680 Ah	80A	24-80
	510 ÷ 620 Ah	810 ÷ 990 Ah	620 ÷ 760 Ah	90A	24-90
	560 ÷ 690 Ah	900 ÷ 1100 Ah	690 ÷ 850 Ah	100A	24-100
	680 ÷ 830 Ah	1080 ÷ 1320 Ah	830 ÷ 1020 Ah	120A	24-120
36V	280 ÷ 340 Ah	450 ÷ 550 Ah	350 ÷ 420 Ah	50A	36-50
	340 ÷ 410 Ah	540 ÷ 660 Ah	420 ÷ 510 Ah	60A	36-60
	390 ÷ 480 Ah	630 ÷ 770 Ah	480 ÷ 590 Ah	70A	36-70
	450 ÷ 550 Ah	720 ÷ 880 Ah	550 ÷ 680 Ah	80A	36-80
	510 ÷ 620 Ah	810 ÷ 990 Ah	620 ÷ 760 Ah	90A	36-90
48V	280 ÷ 340 Ah	450 ÷ 550 Ah	350 ÷ 420 Ah	50A	48-50
	340 ÷ 410 Ah	540 ÷ 660 Ah	420 ÷ 510 Ah	60A	48-60
	420 ÷ 520 Ah	680 ÷ 830 Ah	520 ÷ 630 Ah	75A	48-75
72V	170 ÷ 210 Ah	270 ÷ 330 Ah	210 ÷ 255 Ah	30A	72-30
	230 ÷ 280 Ah	360 ÷ 440 Ah	275 ÷ 340 Ah	40A	72-40
	280 ÷ 340 Ah	450 ÷ 550 Ah	350 ÷ 420 Ah	50A	72-50
80V	170 ÷ 210 Ah	270 ÷ 330 Ah	210 ÷ 255 Ah	30A	80-30
	230 ÷ 280 Ah	360 ÷ 440 Ah	275 ÷ 340 Ah	40A	80-40
96V	140 ÷ 170 Ah	230 ÷ 280 Ah	175 ÷ 210 Ah	25A	96-25
	170 ÷ 210 Ah	270 ÷ 330 Ah	210 ÷ 255 Ah	30A	96-30
	200 ÷ 240 Ah	315 ÷ 380 Ah	240 ÷ 300 Ah	35A	96-35

GREEN SERIES MODULAR THREE-PHASE BATTERY CHARGERS

Modular three-phase battery chargers
up to 6 modules

High frequency switching technology

Scalable & flexible

High efficiency technology for optimal
battery thermal performances

Programmable via front panel or USB type A/B port

Suitable for Lead-Acid, Sealed and Gel Traction
batteries

CAN/CAN-open BUS communication for
Lithium batteries

High efficiency over 90%

Various configurations available

Multi voltage/ multi current configurable modules

Easy to service and repair

Modular fail-proof design - module failure
does not interrupt charging process

Customizable charging curves through software

Integrated data logger

HF View software included



Available charger modules:

- A: OUTPUT: 24V-36V-48V selectable; max 50A
INPUT: 200/208-240/400/440/480 Vac - 50-60 Hz
- B: OUTPUT: 72V- 80V selectable; max 33A
INPUT: 200/208-240/400/440/480 Vac - 50-60 Hz
- C: OUTPUT: 96V; max 25A
INPUT: 400/440/480 Vac - 50-60 Hz

		NUMBER OF MODULES (max programmable current)					
		1	2	3	4	5	6
24 V	A	50 A	100 A	150 A	200 A	250 A	300 A
36 V		50 A	100 A	150 A	200 A	250 A	300 A
48 V		50 A	100 A	150 A	200 A	250 A	300 A
72 V	B	33 A	66 A	100 A	130 A	160 A	200 A
80 V		33 A	66 A	100 A	130 A	160 A	200 A
96 V	C	25 A	50 A	75 A	100 A	125 A	150 A

NOTE: maximum current per number of modules. Lower current configuration available

Green6

Green8

GreenX





GREEN6

Main features:

Modular system (3 configurable modules)

Power up to 8 kW, up to 150A @ 48V,

up to 100A @ 80V, up to 75A @ 96V

Programmable via USB type A/B port or via display

Graphical display

APPLICATIONS



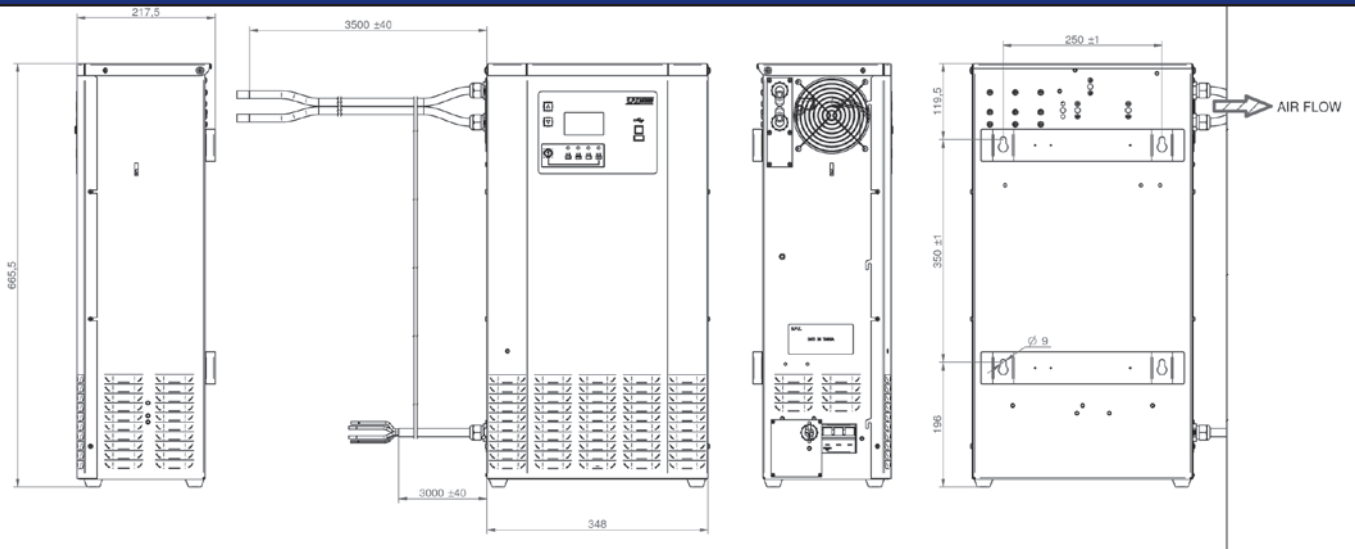

DIMENSIONS (LxWxH): 348x665,50x217,5 mm – 13.70x26.20x8.56 in.

WEIGHT: 35 Kg - 77.16 lbs

PROTECTION GRADE IP20

INPUT VOLTAGE: 200/208-240/400/480 Vac – 50-60 Hz

Battery Voltage	IUla Wet 8h Range (C5)	IUla Wet 12h Range (C5)	IUla Gel PzV 10-14h Range (C5)	Charging Current	Model
24V	280÷340 Ah	450÷550 Ah	350÷420 Ah	50A	24-50
	340÷410 Ah	540÷660 Ah	420÷510 Ah	60A	24-60
	390÷480 Ah	630÷770 Ah	480÷590 Ah	70A	24-70
	450÷550 Ah	720÷880 Ah	550÷680 Ah	80A	24-80
	560÷690 Ah	900÷1100 Ah	690÷850 Ah	100A	24-100
	680÷830 Ah	1080÷1320 Ah	830÷1020 Ah	120A	24-120
	840÷1030 Ah	1350÷1650 Ah	1040÷1270 Ah	150A	24-150
36V	280÷340 Ah	450÷550 Ah	350÷420 Ah	50A	36-50
	340÷410 Ah	540÷660 Ah	420÷510 Ah	60A	36-60
	390÷480 Ah	630÷770 Ah	480÷590 Ah	70A	36-70
	450÷550 Ah	720÷880 Ah	550÷680 Ah	80A	36-80
	560÷690 Ah	900÷1100 Ah	690÷850 Ah	100A	36-100
	680÷830 Ah	1080÷1320 Ah	830÷1020 Ah	120A	36-120
	840÷1030 Ah	1350÷1650 Ah	1040÷1270 Ah	150A	36-150
48V	280÷340 Ah	450÷550 Ah	350÷420 Ah	50A	48-50
	340÷410 Ah	540÷660 Ah	420÷510 Ah	60A	48-60
	390÷480 Ah	630÷770 Ah	480÷590 Ah	70A	48-70
	450÷550 Ah	720÷880 Ah	550÷680 Ah	80A	48-80
	560÷690 Ah	900÷1100 Ah	690÷850 Ah	100A	48-100
	680÷830 Ah	1080÷1320 Ah	830÷1020 Ah	120A	48-120
	730÷890 Ah	1170÷1430 Ah	900÷1100 Ah	130A	48-130
	840÷1030 Ah	1350÷1650 Ah	1040÷1270 Ah	150A	48-150
72V	170÷210 Ah	270÷330 Ah	210÷255 Ah	30A	72-30
	230÷280 Ah	360÷440 Ah	275÷340 Ah	40A	72-40
	280÷340 Ah	450÷550 Ah	350÷420 Ah	50A	72-50
	340÷410 Ah	540÷660 Ah	420÷510 Ah	60A	72-60
	450÷550 Ah	720÷880 Ah	550÷680 Ah	80A	72-80
	560÷690 Ah	900÷1100 Ah	690÷850 Ah	100A	72-100
80V	170÷210 Ah	270÷330 Ah	210÷255 Ah	30A	80-30
	230÷280 Ah	360÷440 Ah	275÷340 Ah	40A	80-40
	280÷340 Ah	450÷550 Ah	350÷420 Ah	50A	80-50
	340÷410 Ah	540÷660 Ah	420÷510 Ah	60A	80-60
	450÷550 Ah	720÷880 Ah	550÷680 Ah	80A	80-80
	560÷690 Ah	900÷1100 Ah	690÷850 Ah	100A	80-100
96V	110÷140 Ah	180÷220 Ah	140÷170 Ah	20A	96-20
	140÷170 Ah	230÷280 Ah	170÷210 Ah	25A	96-25
	170÷210 Ah	270÷330 Ah	210÷250 Ah	30A	96-30
	230÷280 Ah	360÷440 Ah	280÷340 Ah	40A	96-40
	280÷340 Ah	450÷550 Ah	350÷420 Ah	50A	96-50
	340÷410 Ah	540÷660 Ah	420÷510 Ah	60A	96-60
	390÷480 Ah	630÷770 Ah	480÷590 Ah	70A	96-70
	420÷520 Ah	680÷830 Ah	520÷630 Ah	75A	96-75



GREEN8

Main features:

Modular system (4 configurable modules)

Power up to 10.5 kW, up to 200A @ 48V,

up to 130A @ 80V, up to 100A @ 96V

Programmable via USB type A/B port or via display

Graphical display

APPLICATIONS



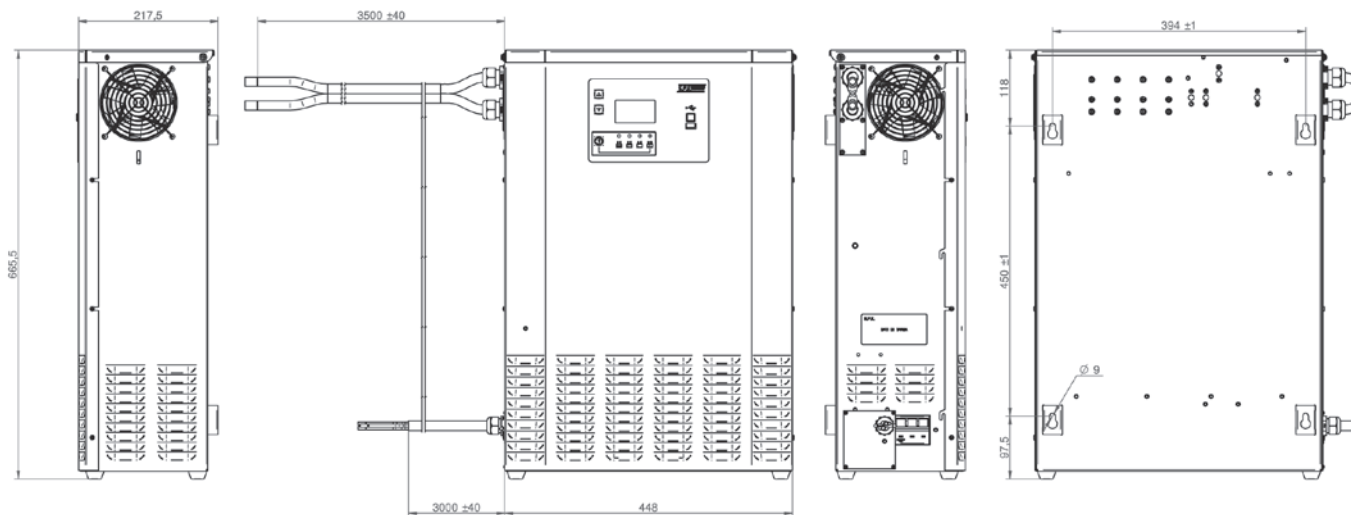

DIMENSIONS (LxWxH): 448x665,50x217,50 mm - 19.45x26.20x8.5 in.

WEIGHT: 43,35 Kg - 95.5 lbs

PROTECTION GRADE IP20

INPUT VOLTAGE: 200/208-240/400/480 Vac – 50-60 Hz

Battery Voltage	IU1a Wet 8h Range (C5)	IU1a Wet 12h Range (C5)	IU1a Gel PzV 10-14h Range (C5)	Charging Current	Model
24V	900 ÷ 1100 Ah	1440 ÷ 1760 Ah	1110 ÷ 1350 Ah	160A	24-160
	1010 ÷ 1240 Ah	1620 ÷ 1980 Ah	1250 ÷ 1520 Ah	180A	24-180
	1130 ÷ 1380 Ah	1800 ÷ 2200 Ah	1380 ÷ 1690 Ah	200A	24-200
36V	900 ÷ 1100 Ah	1440 ÷ 1760 Ah	1110 ÷ 1350 Ah	160A	36-160
	1010 ÷ 1240 Ah	1620 ÷ 1980 Ah	1250 ÷ 1520 Ah	180A	36-180
	1130 ÷ 1380 Ah	1800 ÷ 2200 Ah	1380 ÷ 1690 Ah	200A	36-200
48V	900 ÷ 1100 Ah	1440 ÷ 1760 Ah	1110 ÷ 1350 Ah	160A	48-160
	1010 ÷ 1240 Ah	1620 ÷ 1980 Ah	1250 ÷ 1520 Ah	180A	48-180
	1130 ÷ 1380 Ah	1800 ÷ 2200 Ah	1380 ÷ 1690 Ah	200A	48-200
72V	620 ÷ 760 Ah	990 ÷ 1210 Ah	760 ÷ 930 Ah	110A	72-110
	680 ÷ 830 Ah	1080 ÷ 1320 Ah	830 ÷ 1020 Ah	120A	72-120
	730 ÷ 890 Ah	1170 ÷ 1430 Ah	900 ÷ 1100 Ah	130A	72-130
80V	620 ÷ 760 Ah	990 ÷ 1210 Ah	760 ÷ 930 Ah	110A	80-110
	680 ÷ 830 Ah	1080 ÷ 1320 Ah	830 ÷ 1020 Ah	120A	80-120
	730 ÷ 890 Ah	1170 ÷ 1430 Ah	900 ÷ 1100 Ah	130A	80-130
96V	450 ÷ 550 Ah	720 ÷ 880 Ah	550 ÷ 680 Ah	80A	96-80
	560 ÷ 690 Ah	900 ÷ 1100 Ah	690 ÷ 850 Ah	100A	96-100



GREENX

Main features:

Modular system (5-6 configurable modules)

Power up to 16 kW, 300A @ 48 V,

up to 200A @ 80 V, up to 150A @ 96V

Programmable via USB type A/B port or via display

Graphical display

APPLICATIONS



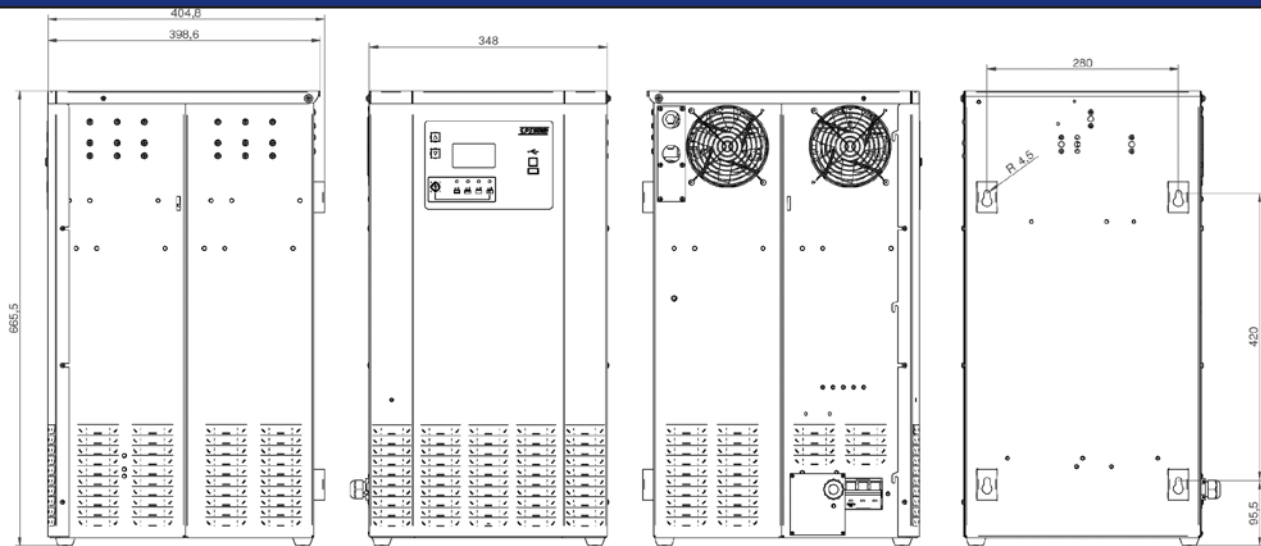

DIMENSIONS (LxWxH): 348x665,50x400,10 mm – 13.70x26.20x15.75 in.

WEIGHT: 61 Kg – 134.48 lbs

PROTECTION GRADE IP20

ONLY INPUT VOLTAGE: 400/480Vac – 50-60 Hz

Battery Voltage	IU1a Wet 8h Range (C5)	IU1a Wet 12h Range (C5)	IU1a Gel PzV 10-14h Range (C5)	Charging Current	Model
24V	1240 ÷ 1510 Ah	1980 ÷ 2420 Ah	1520 ÷ 1860 Ah	220A	24-220
	1410 ÷ 1720 Ah	2250 ÷ 2750 Ah	1730 ÷ 2120 Ah	250A	24-250
	1580 ÷ 1930 Ah	2520 ÷ 3080 Ah	1940 ÷ 2370 Ah	280A	24-280
	1690 ÷ 2060 Ah	2700 ÷ 3300 Ah	2080 ÷ 2540 Ah	300A	24-300
36V	1240 ÷ 1510 Ah	1980 ÷ 2420 Ah	1520 ÷ 1860 Ah	220A	36-220
	1410 ÷ 1720 Ah	2250 ÷ 2750 Ah	1730 ÷ 2120 Ah	250A	36-250
	1580 ÷ 1930 Ah	2520 ÷ 3080 Ah	1940 ÷ 2370 Ah	280A	36-280
	1690 ÷ 2060 Ah	2700 ÷ 3300 Ah	2080 ÷ 2540 Ah	300A	36-300
48V	1240 ÷ 1510 Ah	1980 ÷ 2420 Ah	1520 ÷ 1860 Ah	220A	48-220
	1410 ÷ 1720 Ah	2250 ÷ 2750 Ah	1730 ÷ 2120 Ah	250A	48-250
	1580 ÷ 1930 Ah	2520 ÷ 3080 Ah	1940 ÷ 2370 Ah	280A	48-280
	1690 ÷ 2060 Ah	2700 ÷ 3300 Ah	2080 ÷ 2540 Ah	300A	48-300
72V	840 ÷ 1030 Ah	1350 ÷ 1650 Ah	1040 ÷ 1270 Ah	150A	72-150
	900 ÷ 1100 Ah	1440 ÷ 1760 Ah	1110 ÷ 1350 Ah	160A	72-160
	1010 ÷ 1240 Ah	1620 ÷ 1980 Ah	1250 ÷ 1520 Ah	180A	72-180
80V	1130 ÷ 1380 Ah	1800 ÷ 2200 Ah	1380 ÷ 1690 Ah	200A	72-200
	840 ÷ 1030 Ah	1350 ÷ 1650 Ah	1040 ÷ 1270 Ah	150A	80-150
	900 ÷ 1100 Ah	1440 ÷ 1760 Ah	1110 ÷ 1350 Ah	160A	80-160
	1010 ÷ 1240 Ah	1620 ÷ 1980 Ah	1250 ÷ 1520 Ah	180A	80-180
96V	1130 ÷ 1380 Ah	1800 ÷ 2200 Ah	1380 ÷ 1690 Ah	200A	80-200
	700 ÷ 860 Ah	1130 ÷ 1380 Ah	870 ÷ 1060 Ah	125A	96-125
	840 ÷ 1030 Ah	1350 ÷ 1650 Ah	1040 ÷ 1270 Ah	150A	96-150

DAY OF THE WEEK	START TIME	CHARGE IN	STOP TIME	CHARGE MODE
SUNDAY	8:00	2	8:00:00	SCHEDULE
MONDAY	8:00	2	8:00:00	SCHEDULE
TUESDAY	8:00	2	8:00:00	SCHEDULE
WEDNESDAY	8:00	2	8:00:00	SCHEDULE
THURSDAY	8:00	2	8:00:00	SCHEDULE
FRIDAY	8:00	2	8:00:00	SCHEDULE
SATURDAY	8:00	2	8:00:00	SCHEDULE

REAL TIME CALENDAR

Configures charging profile depending on time/date. S.P.E. RTC is the perfect feature for opportunity charge, that allows users to set charging curves during the day, the week and the year. Switch off the charger does not affect hour setting thanks to the primary lithium battery integrated in the RTC module.



AIR PUMP

Rechargers batteries with air circulation option. Available for all three-phase GREEN chargers, this feature, integrated as a base of the charger, mixes the electrolyte of the Lead Acid battery, allowing a faster charging operation and reduced maintenance thanks to the lower consumption of water.



FLOOR BATTERY CHARGER STAND

Galvanized sheet stand, ideal for every GREEN series charger, can be used in absence of walls, allowing suitable installation at the right height. The product is supplied unassembled, for easy transportation of multiple stands on a single skid.



EXTERNAL CHARGER LAMP

Bright external lamp for easy charging status signaling. The product can be installed on the charger or on the floor stand. It indicates the status of the charging via green, yellow and red led. Customizable lights sequence.



ANTISPARK

Automatic power interruption for safe plugs disconnection (extra plug wiring requested).

This option allows to cut off the power of the charger avoiding electric sparks. Charger can be disconnected at maximum power safely. Applicable on DIN plugs only.



NTC TEMPERATURE SENSOR

Temperature monitor for optimal charging process. Monitor the battery temperature during fast charge avoiding overheating and battery damages.



ETHERNET INTERFACE

Remote charger monitor via web server. Collect and aggregate charging information via cabled network. Remote management option of the charger.



WiFi INTERFACE

Wireless remote charger monitor via web server. Collect and aggregate charging information via wireless network. Remote management option of the charger.



2G/3G DATA CARD

2G/3G data card for remote charger monitor via web server. Collect and aggregate charging information via cellular network independently from IT infrastructure. Remote management option of the charger.



DIGITAL I/O

Digital input/output signals for charger interface to complex systems. Multi input/output option to interface the charger to customers' applications. Suitable for driving external power relays i.e. sirens alarms or PLC. Input pins available for remote start signal.



HFView SOFTWARE

Through HFView software, connecting PC and charger with USB cable, allows access to several options:

- Monitor and download charging cycles
- Modify charger configuration of voltage, current profile
- Enable charger options
- Design/modify charging profiles



Sletten 17 - DK 7500 Holstebro