

MODEL **27-Gel**  
 VOLTAGE **12**  
 CAPACITY **91Ah @ 20Hr**  
 MATERIAL **Polypropylene**  
 BATTERY **VRLA GEL / Non-Spillable / Maintenance-Free**  
 COLOR **Maroon (case) Grey (cover)**  
 WATERING **No Watering Required**

**12 VOLT**
**PHYSICAL SPECIFICATIONS**

BCI	MODEL NAME	TERMINAL TYPE <sup>E</sup>	DIMENSIONS <sup>G</sup> INCHES (mm)			WEIGHT <sup>F</sup> LBS. (kg)	INSTALLATION ORIENTATION
			LENGTH	WIDTH	HEIGHT <sup>D</sup>		
27	27-GEL	7	12.73 (323)	6.38 (162)	9.26 (235)	62 (28)	Horizontal and Vertical

**ELECTRICAL SPECIFICATIONS**

VOLTAGE	CAPACITY <sup>A</sup> MINUTES	CAPACITY <sup>B</sup> AMP-HOURS (Ah)					ENERGY (kWh)	INTERNAL RESISTANCE (mΩ)	SHORT CIRCUIT CURRENT (amps)
		@ 25 Amps	5-Hr	10-Hr	20-Hr	100-Hr			
12	179	76	84	91	100	1.20	-	-	

**CHARGING INSTRUCTIONS**

CHARGER VOLTAGE SETTINGS (AT 77°F/25°C)				
SYSTEM VOLTAGE	12V	24V	36V	48V
Maximum Charge Current (A)	13% of C <sub>20</sub>			
Absorption Voltage (2.40 V/cell)	14.40	28.80	43.20	57.60
Float Voltage (2.25 V/cell)	13.50	27.00	40.50	54.00

Do not install or charge batteries in a sealed or non-ventilated compartment. Constant under or overcharging will damage the battery and shorten its life as with any battery.

**CHARGING TEMPERATURE COMPENSATION**

ADD	SUBTRACT
0.003 volt per cell for every 1°C below 25°C 0.0017 volt per cell for every 1°F below 77°F	0.003 volt per cell for every 1°C above 25°C 0.0017 volt per cell for every 1°F above 77°F

**OPERATIONAL DATA**

OPERATING TEMPERATURE	SELF DISCHARGE
-4°F to 113°F (-20°C to +45°C). At temperatures below 32°F (0°C) maintain a state of charge greater than 60%.	Less than 3% per month depending on storage temperature conditions

**RECYCLE RESPONSIBLY**

Din forhandler



GACELL A/S - Sletten 17 - DK 7500 Holstebro - 961 02 961

**STATE OF CHARGE MEASURE OF OPEN-CIRCUIT VOLTAGE**

PERCENTAGE CHARGE	CELL	12 VOLT
100	2.14	12.84
75	2.11	12.66
50	2.06	12.36
25	2.00	12.00
0	1.97	11.82

## TROJAN 27-GEL PERFORMANCE

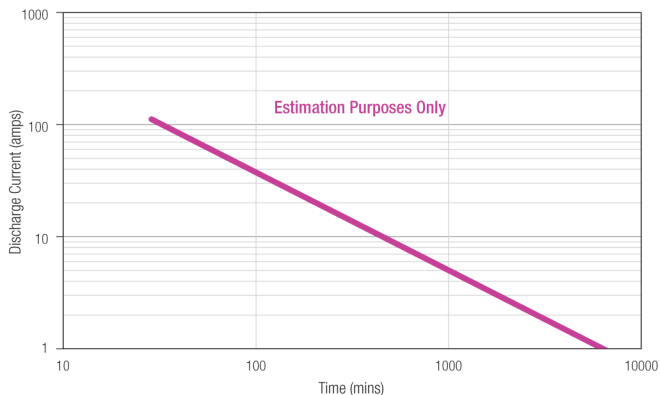

## PERCENT CAPACITY VS. TEMPERATURE

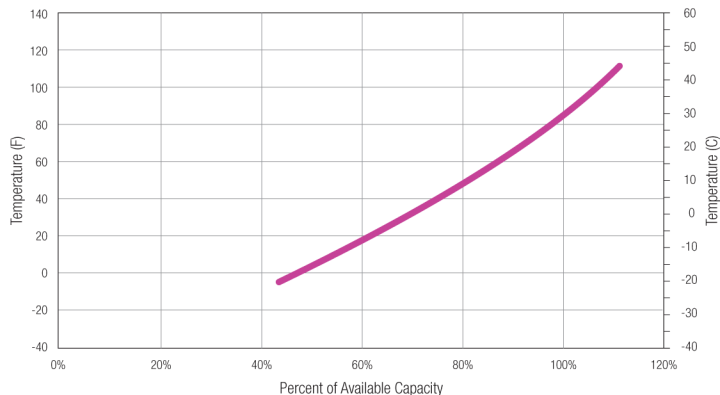

## BATTERY DIMENSIONS (shown with UT)

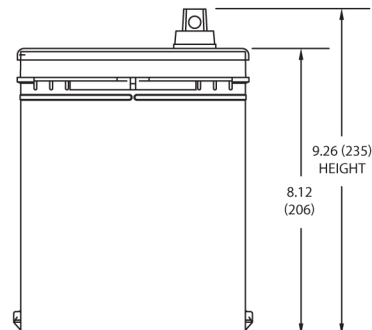
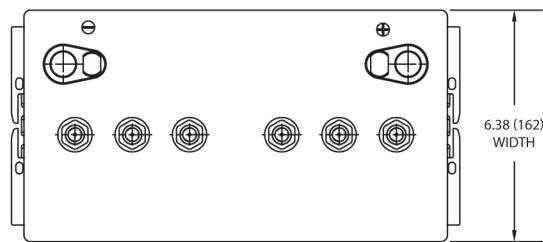
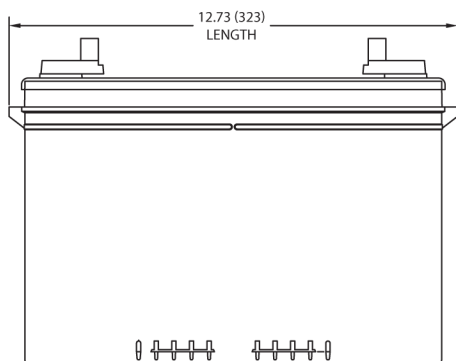

## TERMINAL CONFIGURATIONS<sup>E</sup>

7	UT	UNIVERSAL TERMINAL
		<p><b>Terminal Height Inches (mm)</b> 1.10 (28)</p> <p><b>Torque Values in-lb (Nm)</b> 95 – 105 (11 – 12)</p> <p><b>Bolt</b> 5/16" – 18</p>

Din forhandler



GACELL A/S - Sletten 17 - DK 7500 Holstebro - 961 02 961

- A. The number of minutes a battery can deliver when discharged at a constant rate at 80°F (27°C) and maintain a voltage above 1.75 V/cell. Capacities are based on peak performance.
- B. The amount of amp-hours (Ah) a battery can deliver when discharged at a constant rate at 80°F (27°C) and maintain a voltage above 1.75 V/cell. Capacities are based on peak performance.
- C. Dimensions are based on nominal size. Dimensions may vary depending on type of handle or terminal. Batteries to be mounted with .5 inches (12.7 mm) spacing minimum.

- D. Dimensions taken from bottom of the battery to the highest point on the battery. Heights may vary depending on type of terminal.
- E. Terminal images are representative only.
- F. Weight may vary.



Designed in compliance with applicable BCI, DIN, BS and IEC standards. Tested in compliance with BCI and IEC standards.



800.423.6569 / +1.562.236.3000 / trojanbattery.com

27-GeL\_DS\_072619

© 2019 Trojan Battery Company, LLC. All rights reserved. Trojan Battery Company is not liable for damages that may result from any information provided in or omitted from this publication, under any circumstances. Trojan Battery Company reserves the right to make adjustments to this publication at any time, without notice or obligation.