

LPL Series-Long Life Standby

LPL12-200(12V210Ah)



Specifications

Rated Voltage	12V	
Nominal Capacity	C ₂₀ , 1.80V/cell	210Ah
Dimension	Length	522±2mm (20.6 inches)
	Width	240±2mm (9.45 inches)
	Container Height	218±2mm (8.58 inches)
	Total Height	224±2mm (8.81 inches)
Approx Weight	62.3kg (137.3 lbs)	
Terminal	M8	
Container Material	ABS	
Rated Capacity(25°C)	210.0 Ah	C20(10.5A, 1.80V/cell)
	200.0 Ah	C10(20.0A, 1.80V/cell)
	169.5 Ah	C5(33.9A, 1.75V/cell)
	154.2 Ah	C3(51.4A, 1.75V/cell)
	116.2 Ah	C1(116.2A, 1.60V/cell)
Max. Discharge Current	2100A (5s)	
Internal Resistance(25°C)	Approx 3.2mΩ	
Operating Temp. Range	Discharge	-15 ~ 50°C (5 ~ 122°F)
	Charge	-20 ~ 40°C (-4 ~ 104°F)
	Storage	-15 ~ 40°C (5 ~ 104°F)
Nominal Operating Temp. Range	25±3°C (77±5°F)	
Cycle Use	Initial Charging Current less than 60.0A. Voltage 14.4V~15.0V at 25°C(77°F)Temp. Coefficient -30mV/°C	
	Standby Use	
Effect of temp. to Capacity	Initial Charging Current less than 60.0A. Voltage 13.5V~13.8V at 25°C(77°F)Temp. Coefficient -20mV/°C	
	40°C (104°F)	103%
	25°C (77°F)	100%
	0°C (32°F)	86%
Self Discharge	LPL series batteries may be stored for up to 6 months at 25°C(77°F) and then a freshening charge is required. For higher temperatures the time interval will be shorter.	

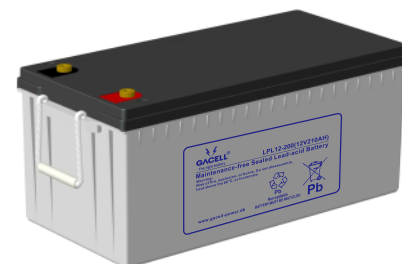

Layout

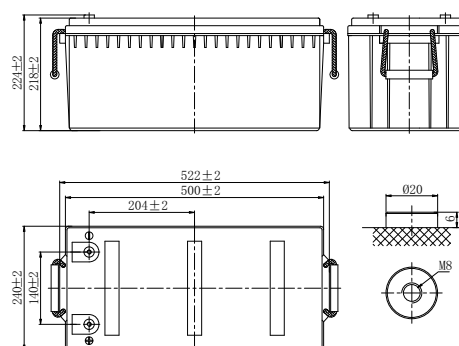

Constant Current Discharge (Amperes) at 25°C (77°F)

F.V/Time	5min	10min	15min	30min	45min	1h	1.5h	2h	3h	4h	5h	6h	8h	10h	20h
1.85V/cell	395.3	281.1	243.7	157.7	117.8	101.8	75.3	63.3	46.4	36.4	31.6	27.9	21.4	19.1	10.1
1.80V/cell	449.6	319.1	276.2	171.7	124.8	105.5	77.9	65.4	50.4	38.9	33.3	29.9	22.6	20.0	10.5
1.75V/cell	488.3	346.0	299.0	175.2	129.3	110.7	81.9	68.8	51.4	39.6	33.9	30.2	22.7	20.2	10.6
1.70V/cell	522.1	368.9	317.6	178.7	131.9	112.9	83.5	70.2	52.4	40.3	34.4	30.3	23.0	20.4	10.7
1.65V/cell	540.3	380.6	326.8	181.3	133.8	114.6	84.7	71.2	52.9	40.9	35.1	30.5	23.3	20.7	10.8
1.60V/cell	559.4	393.6	337.0	183.9	135.7	116.2	85.9	72.3	53.4	41.4	35.6	30.7	23.6	20.9	11.0

Constant Power Discharge (Watts/cell) at 25°C (77°F)

F.V/Time	5min	10min	15min	30min	45min	1h	1.5h	2h	3h	4h	5h	6h	8h	10h	20h
1.85V/cell	738.3	528.8	461.4	301.3	226.4	197.0	146.1	123.2	90.8	71.5	62.3	55.1	42.5	38.0	20.2
1.80V/cell	825.9	591.5	516.2	325.5	238.3	202.9	150.3	126.6	98.0	76.0	65.2	58.9	44.6	39.7	20.9
1.75V/cell	881.4	631.3	550.9	329.6	245.5	212.0	157.3	132.7	99.7	77.2	66.2	59.2	44.7	40.1	21.1
1.70V/cell	926.6	663.7	579.1	333.4	248.6	215.1	159.7	134.8	101.2	78.2	67.1	59.4	45.4	40.4	21.3
1.65V/cell	941.7	674.5	588.6	335.7	250.9	217.0	161.2	136.2	101.8	79.2	68.2	59.5	45.9	40.9	21.5
1.60V/cell	954.9	683.9	596.8	337.2	252.1	218.6	162.5	137.3	102.2	79.7	68.9	59.8	46.4	41.3	21.7

LPL Series-Long Life Standby LPL12-200(12V210Ah)



Applications

- UPS and EPS
- Emergency light
- Railway signal and aircraft signal system
- Marine and power stations
- Alarm and security system
- Electronic apparatus and equipment
- Communication power supply, DC power supply

General Features

- 12 years design life (25°C)
- Grid refining technology and the thicker plates are used to extend the battery standby life and reduce the plate grid corrosion speed
- Using oxygen recombination technology: maintenance-free
- Unique vent valve design: control water losing, prevent air and spark going inside

Standards

- Compliance with IEC 60896 standards, EU Battery Directive

Discharge Characteristics

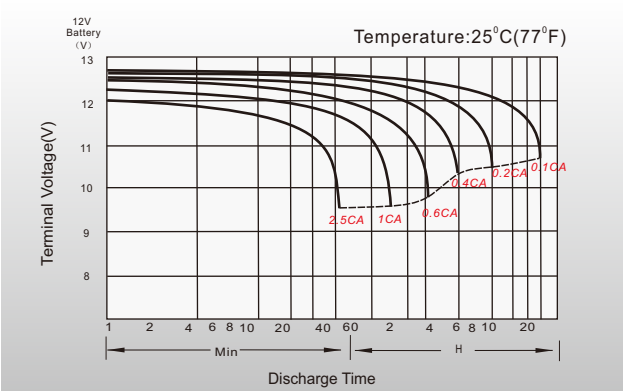

Float Charging Characteristics

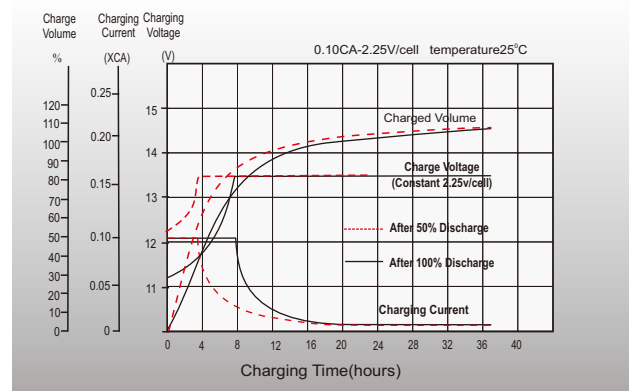

Temperature Effects in Relation to Battery Capacity

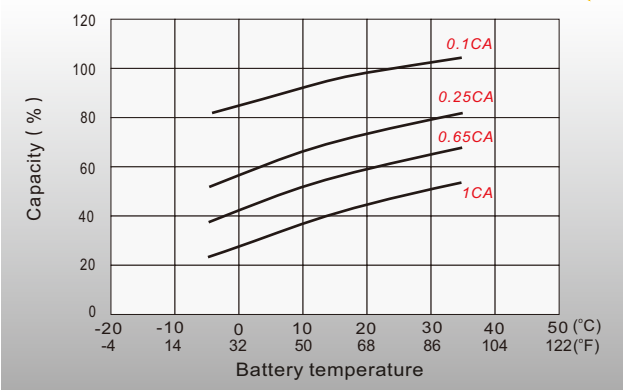

Effect of Temperature on Long Term Float Life

