



# CBHD1 COMPACT

Main features:

Reduced weight and dimensions

Power from 30W up to 120W

Current from 2,5A to 5A

Available with Led on side or Led on top

**Din forhandler**



# GACELL®

## The right battery

**GACELL A/S - Sletten 17 - DK 7500 Holstebro - 961 02 961**

APPLICATIONS



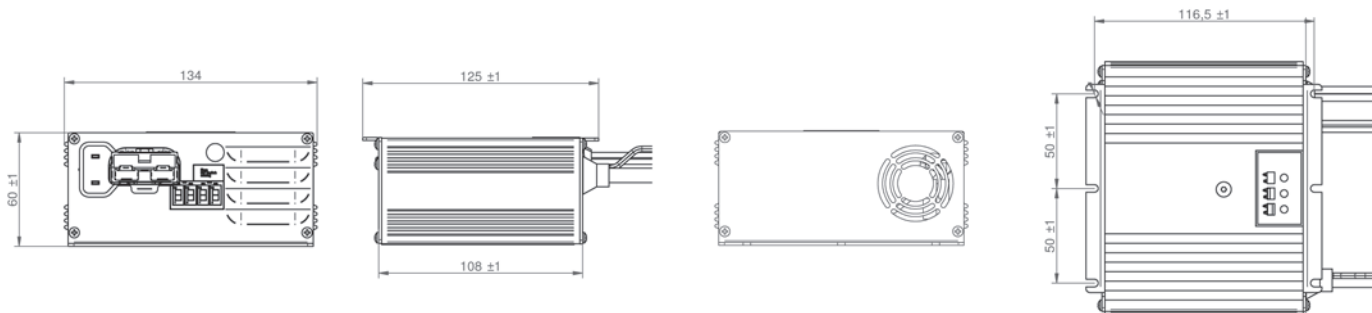

DIMENSIONS (LxWxH): 134x125x60 mm - 5.28x4.92x2.36 in  
 WEIGHT: 1,20 Kg - 2.65 lbs  
 PROTECTION GRADE IP30  
 INPUT VOLTAGE: Universal 100 ÷ 240 Vac – 50-60 Hz

Battery Voltage	Battery Range		Charging Current	Model
	5h	20h		
12V	10÷25 Ah	15÷30 Ah	2,5A	12-2,5
	20÷50 Ah	30÷60 Ah	5A	12-5
24V	10÷25 Ah	15÷30 Ah	2,5A	24-2,5
	20÷50 Ah	30÷60 Ah	5A	24-5

**Din forhandler**



**GACELL A/S - Sletten 17 - DK 7500 Holstebro - 961 02 961**

